

Panasonic



# General Catalogue 2020-

## Electrical Construction Materials

### Panasonic Life Solutions Vietnam Co., Ltd

#### ■ Showroom Ho Chi Minh:

675-677 Dien Bien Phu St., Ward 25,  
Binh Thanh District, HCM City, Vietnam.  
Hotline: 1900 6711

#### ■ Factory:

No. 1 VSIP II-A, Road No.12, Vietnam-Singapore II-A Industrial Park,  
Vinh Tan Ward, Tan Uyen Town, Binh Duong Province, Vietnam.  
Tel: [0274] 222 0239 • Fax: [0274] 222 0932



#### ■ Showroom Ha Noi:

83 Lang St., Nga Tu So Ward,  
Dong Da District, Ha Noi, Vietnam.  
Hotline: 1900 6711

#### ■ Presentative Office:

5th Floor, An Phu Plaza, 117-119 Ly Chinh Thang St.,  
Ward 7, District 3, HCM City, Vietnam.  
Tel: [028] 3813 4591  
Website: [www.panasonic.net/ls/vn](http://www.panasonic.net/ls/vn)

# Panasonic®

## To the next stage

Panasonic has been presented in the Vietnam market over many years. During all this time, our customers have come to appreciate Panasonic and our extensive range of products from Home Appliances to Wiring Devices. Playing a key role in Panasonic company history since 1918, Panasonic has established a reputation for safety, durability and comfort around the world.

As Panasonic continues to develop new product technologies along with highly advanced manufacturing abilities, our concepts regarding safety and comfort continue to evolve. Panasonic's uncompromising commitment makes it possible to offer our Vietnam customers a higher level of satisfaction with any of our diverse product categories.



*Panasonic Original Product  
1918  
Attachment plug*

# CONTENTS

P.16		WIRING DEVICE MINERVA	P.88		GD BREAKER
P.22		WIRING DEVICE Halumie	P.96		WHITE CONDUIT
P.26		WIRING DEVICE Gen-X	P.102		FULL-2WAY REMOTE LIGHTING CONTROL SYSTEM
P.30		WIRING DEVICE FULL-COLOR WIDE SERIES Refina A-TYPE	P.104		FACTORY LINE SYSTEMS
P.36		WIRING DEVICE FULL-COLOR WIDE SERIES Refina BS-TYPE	P.108		PHOTOVOLTAIC MODULE HIT ®
P.40		WIRING DEVICE FULL-COLOR WIDE SERIES	P.115		VENTILATING FAN
P.46		WIRING DEVICE FULL-COLOR	P.136		BATHROOM DRYER
P.51		WIRING DEVICE INDUSTRIAL SOCKET	P.138		AIR CURTAIN
P.64		WIRING DEVICE EXTENSION CORD WITH SAFETY SHUTTER & BREAKER	P.140		AIR MOVING EQUIPMENT
P.66		WIRING DEVICE FLOOR OUTLET SERIES	P.144		ENERGY RECOVERY VENTILATOR
P.72		PASSIVE INFRARED SENSOR	P.152		HAND DRYER
P.75		SMOKE DETECTOR	P.154		CEILING FAN
P.76		AUTOMATIC TIME SWITCH	P.163		WALL FAN
P.79		MCB/RCBO/ MCCB	P.176		AIR PURIFIER
P.83		ELB BREAKER	P.178		PUMP

# Company Profile

Since the Panasonic Corporation was founded in 1918, it has based corporate activities on a Basic Management Objective. Through its business activities, Panasonic strives to help society progress and develop so as to improve the well-being of people throughout the world. By focusing on people, we intend to enrich their lifestyles as we move forward together with our customers.

Panasonic Life Solutions Company handles diverse businesses. The Energy Systems Business supplies everything from wiring devices and distribution switchboards to photovoltaic modules, storage battery systems and energy management devices. The Lighting Business innovates illumination in an energy-efficient manner with LED lighting bulbs, fixtures and other devices. The Housing Systems Business's comprehensive range of residential equipment and building materials create comfortable living environments. The Environmental Systems Business helps to reduce environmental impact by maintaining good air quality and by purifying contaminated water and soil.

We are helping to create an environment in which people around the world can live in comfort while minimizing environmental harm. Harmoniously combining ecology and comfort is our vision. We seek to achieve this by creating solutions in residential and non-residential (buildings and public facilities) fields, leveraging Panasonic Group's extensive product lines. As we address issues our worldwide customers face with Panasonic solutions, we contribute to realizing a sustainable society.

## Panasonic - dedicated to eco-conscious manufacturing

Manufacturing eco-conscious products that do not harm humans and the environment have always been a priority for Panasonic. Conforming to the RoHS directive originating from the EU, Panasonic restricts the usage of hazardous substances that might adversely affect the environment and humans such as lead, cadmium, chromium and mercury, etc. Panasonic contributes to creating a greener environment with lead-free welding, cadmium-free contacts and hexavalent chromium-free plating.



# Products Concept

## Panasonic's "Five-Elements" Design Concept

The integrated system that our product development process is based on makes it possible to produce consistently high-quality products. It begins with assessing market needs accurately goes on to develop advanced basic technologies and extends to product planning, design and production, all the way to sales and after-sales activities.

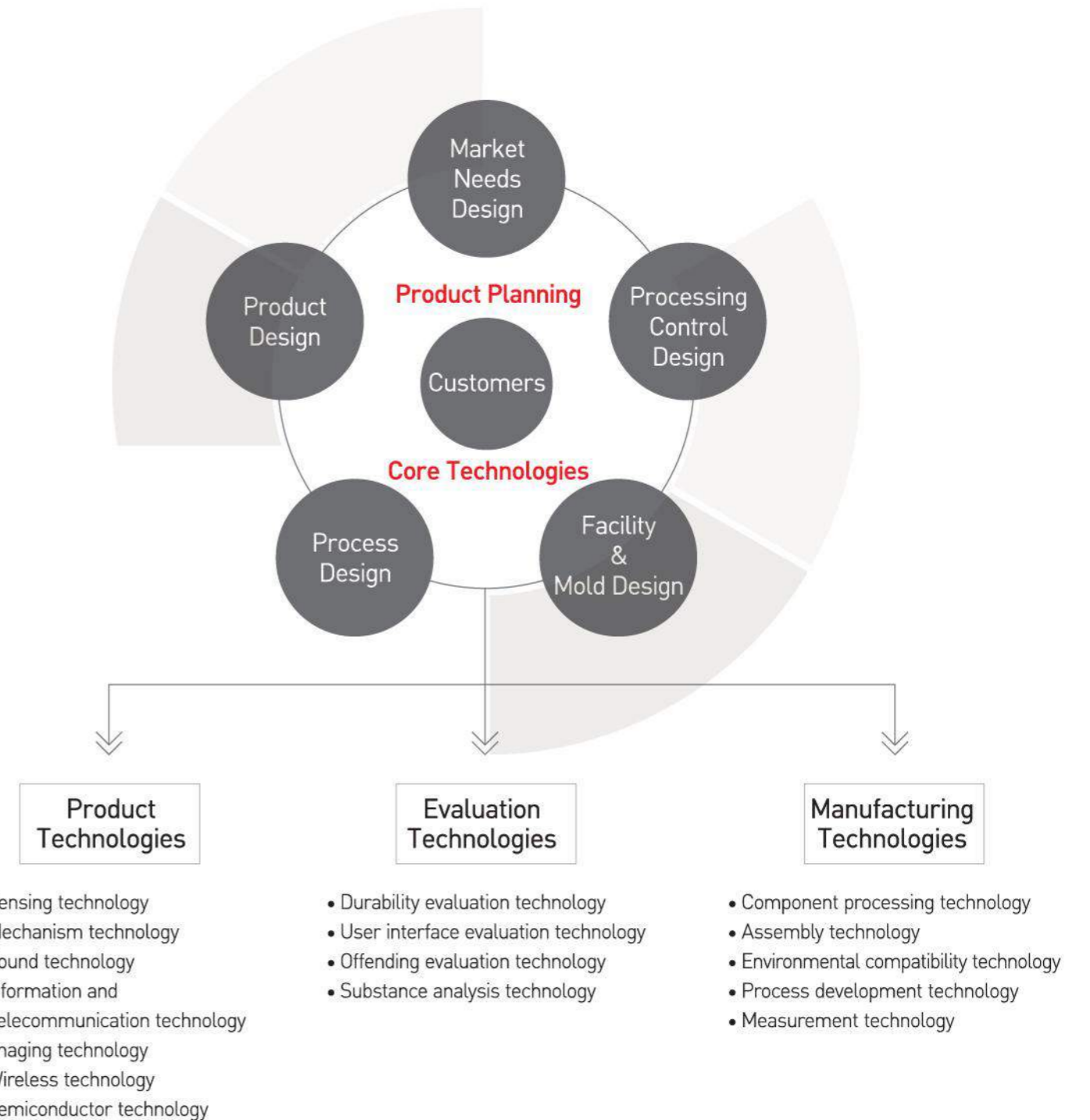



# Panasonic's products will continue to work in diverse settings all around the world.

Home and lifestyle environments, as well as business environments which evolve every day.

The Panasonic group has made available to you safe and secure products which you can use in various places, whether it is your home, or office, or in various institutions or public areas.

Our rich and varied product range offers true value to our customers.

We shall continue to offer you the best in smart living.



## HOME

-  MINERVA
-  HALUMIE
-  MCB/RCBO
-  VENTILATING FAN
-  CEILING FAN
-  WALL FAN
-  AIR PURIFIER
-  PUMP



## CONDOMINIUM

-  MINERVA
-  GEN X
-  MCCB/MCB/RCBO/GD BREAKER
-  VENTILATING FAN
-  ERV
-  HAND DRYER
-  CEILING FAN
-  AIR PURIFIER



## OFFICE

-  HALUMIE
-  FULL-COLOR WIDE SERIES
-  EXTENSION CORD
-  FLOOR OUTLET SERIES
-  PASSIVE INFRARED SENSOR
-  MCCB/MCB/RCBO/GD BREAKER
-  FULL-2WAY REMOTE LIGHTING CONTROL SYSTEM
-  VENTILATING FAN
-  ERV
-  HAND DRYER



## FACTORY

-  FULL-COLOR WIDE SERIES
-  INDUSTRIAL SOCKET
-  FLOOR OUTLET SERIES
-  PASSIVE INFRARED SENSOR
-  AUTOMATIC TIME SWITCH
-  MCCB/MCB/RCBO/GD BREAKER
-  FACTORY LINE SYSTEMS
-  PHOTOVOL TAIC MODULE HIT®
-  CABINET FAN
-  INDUSTRIAL FAN



## SHOPPING CENTER

-  MINERVA
-  HALUMIE
-  TWIST LOCK
-  FLOOR OUTLET SERIES
-  AUTOMATIC TIME SWITCH
-  MCCB/MCB/RCBO/GD BREAKER
-  VENTILATING FAN
-  AIR CURTAIN
-  AIR MOVING EQUIPMENT
-  ERV
-  HAND DRYER
-  MID FAN



Applying advanced technologies that truly make life better, we live by an unparalleled commitment to product quality. Our approach to product development originates in the DNA of Japanese craftsmanship. Panasonic is building on the Japanese tradition of uncompromising quality control worldwide, developing and manufacturing fine products and delivering them to customers everywhere.

## WORLDWIDE STANDARDS

Safety design conforming to IEC standards

Switches conform to the IEC60669-1 standard (16A 250V-).  
 Socket Outlets conform to the IEC60884-1 standard.  
 MCB/RCBO conform to the IEC60898-1, IEC60947-2, IEC61009 standard.  
 All devices guarantee protection against electric shock and are designed for endurance, service longevity and safety.

### Based on Internationally Accepted Standards

Manufactured based on the industrial norms for environmental conservation and quality assurance prescribed by ISO. We undertake the manufacture of products using processes with high quality and high safety which have cleared the IEC.



Examination and registration card.



**Panasonic now conforms with Conformity Regulation (CR) mark**  
 All Panasonic fans are borne CR mark issued by Vietnam Certification Center (Quacert) in comply with QCVN 4:2009/BKHCN



Panasonic MCB BD-63R and RCBO BDE-63R are tested by Vietnam Quality Assurance and Testing Center 3 (QUATEST 3), in comply with IEC 60898-1 : 2003

Electrical Construction Materials



# Easy To Install

**Panasonic-designing one-touch action products that are easy to install**  
 The All One-Touch Action design concept to assemble devices to Cover Plate and Body Plate. Making the installation process easier than ever, saving both time and labour.

## 1-TOUCH Construction



### ■ Device & Body Plate



### ■ Body Plate & Cover Plate



### Highly efficiency, because of improvements in the utility box.

Sufficient space has been provided to house the connectors, and this has resulted in a higher efficiency than ever before.

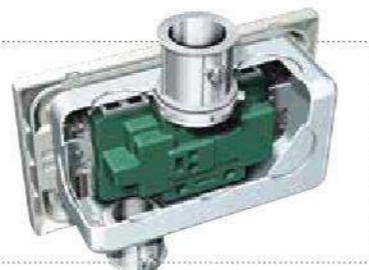

# Various Terminals Available

## We offer a wide range of terminals to suit the electrical cabling requirements of every country

Panasonic has made available various terminals to suit the cabling environment anywhere in the world. With a structure which can be handled with more safety than ever before. Connections can be smoothly made, which leads to labor saving.

### ■ Types of Electrical Cables and Terminals

Terminal	ICON	APPLICABLE WIRE
Quick Connect Terminal	 Quick & 1.5Safety Solid Wire only: 1.5-2.5mm <sup>2</sup>	 Solid OK
	 Solid Wire: 1.5-2.5mm <sup>2</sup> Stranded Wire: 1.5-2.5mm <sup>2</sup>	 Solid Stranded OK

Terminal	ICON	APPLICABLE WIRE
Global Terminal	 Solid Wire: 1.5-4.0mm <sup>2</sup> Stranded Wire: 1.5-4.0mm <sup>2</sup>	 Solid Stranded OK
Pillar Terminal II	 1.5-4.0mm <sup>2</sup> Solid, Stranded and Flexible wire	 Flexible OK

# Safety

## Safety design conforming to IEC standards

Switches conform to the IEC60669-1 standard(16A 250V~). Receptacles conform to the IEC60884-1 standard. All devices guarantee protection against electric shock and are designed for endurance, service longevity and safety.

## Switches

- Designed for long service life (compliant with IEC standard) with 40,000 testing operations at 16A 250V~ full rating.
- Heat-resistant, highly conductive material used for the terminal plate reduces temperature increases in the terminal section.



### ■ Terminal Section Temperature Rise

IEC60669-1 Standard value		Conditions
Initial	45K max.	20A current
Use as 40,000 testing operations		16A current

## Receptacles

- Wide Receptacles secures insulation distance between contacts and external metal parts improving safety. (Compliant with IEC standard which requires insulation distance over 4.5mm)
- Long-life design, capable of 10,000 strokes at 16A 250V ~ full rating.
- Heat-resistant, highly conductive material is used for the blade receptacles and terminal point to reduce temperature increase.



### ■ Terminal Section Temperature Rise

IEC60884-1 Standard value		Conditions
Initial	45K max.	20A current
After 10,000 Strokes		16A current

### ■ Insulation Resistance

IEC60884-1 Standard value	
Initial	5M Ω min.
After 10,000 Strokes	

### ■ Withdrawal Forces

IEC60884-1 Standard value		
After 10,000 Strokes	3 blades	54N max.
	2 blades	50N max.
	Single blades	2N min.

### ■ Electric Strength

IEC60884-1 Standard value	
Initial	2,000V 1 min.
After 10,000 Strokes	1,500V 1 min.

# Security And Comfort

## 1 Flame-retardant Material Urea Resin

Utilizing urea resin improves flame resistance and outstanding anti-tracking prevents electric shocks.

### Completely Insulated Construction

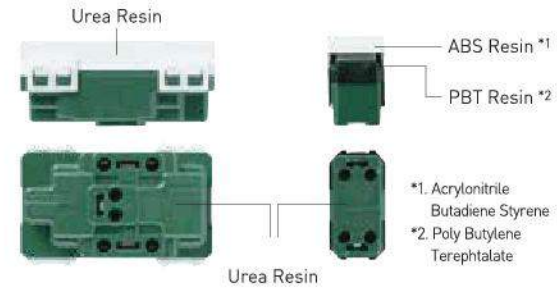

### Protection Against Electric shock

Enclosure Material Characteristics (Reference)

	Urea	PBT	Polycarbonate
Tracking Performance	Excellent	Good	Poor
Heat Deformation	Good	Good	Fair
Self-Extinguishment	Good	Good	Good



Switch



## 2 Durable & Smooth Operations Direct Driving Mechanism

Panasonic's proprietary method helps stabilizing the pressure applied to the contacts to ensure low heat and minimize the arc energy. This process reduces the risk of contact fuse and provides longer lasting resistance.

### Direct Driving Mechanism

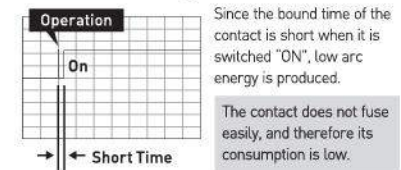

### Seesaw Type of Switching System

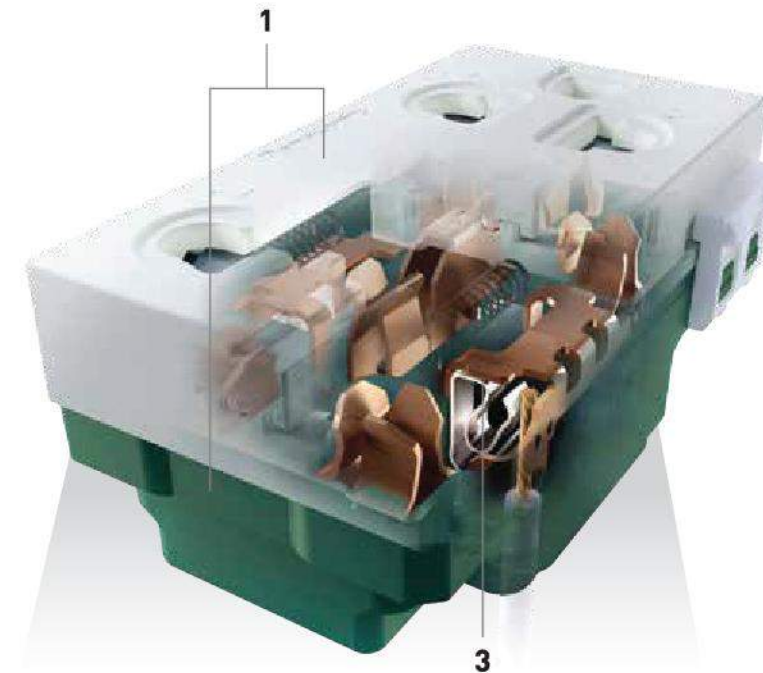
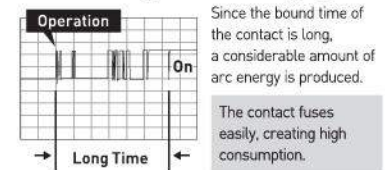

Receptacle



## 3 Quick & Secure Connect Quick-Connect Terminal

These terminals improve site construction quality since fewer tightening screws are required, simplifying connections.

### Reduces the execution time considerably

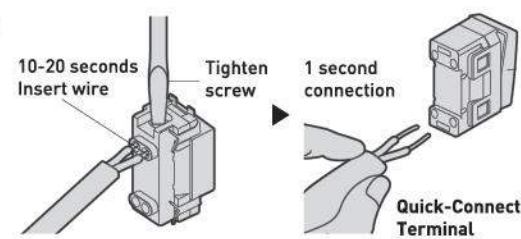

### Tensile strength after connection

IEC60669-1 IEC60884-1 Standard Value	FULL-COLOR WIDE SERIES / Halumie	
IEC Standard	Wire	Strength
30N min.	1.5mm <sup>2</sup> 4.0mm <sup>2</sup>	30N min. or more

# Product Positioning

## (SERIES OF WIRING DEVICES)

Whether living room, office, public space or any other facility, Panasonic enhances its appearance. A wide range of switch and receptacle product series, each with its distinctive designs, color variations and operational ease is offered to ideally match installation requirements.



**MINERVA** **NEW**  
The new Luxury Square Type  
Wiring Device series from Panasonic



**HALUMIE**  
New slim designs to harmonize  
with any living space



**GEN-X**  
Exclusive switch series with ultrathin panel and  
refined appearance adding elegance to your interiors



**FULL-COLOR WIDE SERIES REFINA**  
Wide color range suits modern interiors



**FULL-COLOR WIDE SERIES**  
The beauty of simplicity



**FULL-COLOR SERIES**  
The standard of excellence for any installation



## The new Luxury Square Type Wiring Device series from Panasonic

**NEW STANDARD OF ELEGANCE**

■ Elegant Design and Colors  
Complete the interior design with the elegant finish and perfect shadowing

■ Polishing and frameless surface

■ Small On/Off reversing angle  
For the limitless experience in every usage



Metallic Pearl Gold



Metallic Pearl Gray

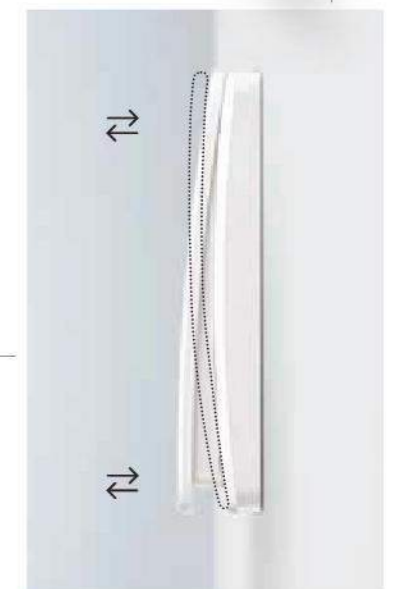



**Switches & Accessories**

**WMT501-VN**

Switch "B", Single Pole  
1-Gang 1-Device  
16AX 250V~



**WMT503-VN**

Switch "B", Single Pole  
1-Gang 2-Devices  
16AX 250V~



**WMT505-VN**

Switch "B", Single Pole  
1-Gang 3-Devices  
16AX 250V~



**WMT501MYZ-VN**

Switch "B", Single Pole  
1-Gang 1-Device  
[Metallic Pearl Gold]  
16AX 250V~



**WMT503MYZ-VN**

Switch "B", Single Pole  
1-Gang 2-Devices  
[Metallic Pearl Gold]  
16AX 250V~



**WMT505MYZ-VN**

Switch "B", Single Pole  
1-Gang 3-Devices  
[Metallic Pearl Gold]  
16AX 250V~



**WMT507-VN**

Switch "B", Single Pole  
1-Gang 4-Devices  
10AX 250V~  
\*Applicable Wire: 1.5-2.5mm<sup>2</sup>  
(Solid and Stranded Wire Only)



**WMT502-VN**

Switch "C", 3Way  
1-Gang 1-Device  
16AX 250V~



**WMT504-VN**

Switch "C", 3Way  
1-Gang 2-Devices  
16AX 250V~



**WMT507MYZ-VN**

Switch "B", Single Pole  
1-Gang 4-Devices  
[Metallic Pearl Gold]  
10AX 250V~  
\*Applicable Wire: 1.5-2.5mm<sup>2</sup>  
(Solid and Stranded Wire Only)



**WMT502MYZ-VN**

Switch "C", 3Way  
1-Gang 1-Device  
[Metallic Pearl Gold]  
16AX 250V~



**WMT504MYZ-VN**

Switch "C", 3Way  
1-Gang 2-Devices  
[Metallic Pearl Gold]  
16AX 250V~



**WMT506-VN**

Switch "C", 3Way  
1-Gang 3-Devices  
16AX 250V~



**WMT508-VN**

Switch "C", 3Way  
1-Gang 4-Devices  
10AX 250V~  
\*Applicable Wire: 1.5-2.5mm<sup>2</sup>  
(Solid and Stranded Wire Only)

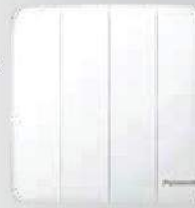

**WMT594-VN**

Switch "E", 4Way  
1-Gang 1-Device  
10AX 250V~



**WMT506MYZ-VN**

Switch "C", 3Way  
1-Gang 3-Devices  
[Metallic Pearl Gold]  
16AX 250V~



**WMT508MYZ-VN**

Switch "C", 3Way  
1-Gang 4-Devices  
[Metallic Pearl Gold]  
10AX 250V~  
\*Applicable Wire: 1.5-2.5mm<sup>2</sup>  
(Solid and Stranded Wire Only)



**WMT594MYZ-VN**

Switch "E", 4Way  
1-Gang 1-Device  
[Metallic Pearl Gold]  
10AX 250V~



**WMT596-VN**

Switch "E", 4Way  
1-Gang 2-Devices  
10AX 250V~



**WMT707K-VN**

Foot Light with Passive Infrared  
Sensor and Illuminance Sensor  
\*Applicable Wire: 0.75-1.5mm<sup>2</sup>  
(Solid and Stranded Wire Only)



**WEC5781W-VN**

Electronic Key Card Switch



**NEW**

**WMT596MYZ-VN**

Switch "E", 4Way  
1-Gang 2-Devices  
[Metallic Pearl Gold]  
10AX 250V~



**WMT707MYZK-VN**

Foot Light with Passive Infrared  
Sensor and Illuminance Sensor  
[Metallic Pearl Gold]  
\*Applicable Wire: 0.75-1.5mm<sup>2</sup>  
(Solid and Stranded Wire Only)



**WEC5781MYZ-VN**

Electronic Key Card Switch  
[Metallic Pearl Gold]



**NEW**

**WSBC7010SW-VN**

Cable Outlet with 20A  
Terminal Block  
\*Applicable Wire  
Input: 2.5-6.0mm<sup>2</sup>  
(Rigid Copper Wire)  
Output: 1.5-2.5mm<sup>2</sup>  
(Flexible Wire)



**NEW**

**WMT540108-VN**

Bell Switch



**NEW**

**WSBC7010MYZ-VN**

Cable Outlet with  
20A Terminal Block  
[Metallic Pearl Gold]  
\*Applicable Wire  
Input: 2.5-6.0mm<sup>2</sup>  
(Rigid Copper Wire)  
Output: 1.5-2.5mm<sup>2</sup>  
(Flexible Wire)



**NEW**

**WMT540108MYZ-VN**

Bell Switch  
[Metallic Pearl Gold]



**NEW**



**Plates \*Compatible with Full-Color WIDE series module (P.42-44)**

**WMT501MYH-VN**

Switch "B", Single Pole  
1-Gang 1-Device  
[Metallic Pearl Gray]  
16AX 250V~



**WMT503MYH-VN**

Switch "B", Single Pole  
1-Gang 2-Devices  
[Metallic Pearl Gray]  
16AX 250V~



**WMT505MYH-VN**

Switch "B", Single Pole  
1-Gang 3-Devices  
[Metallic Pearl Gray]  
16AX 250V~



**WMT6891-VN**

1-TOUCH PLATE  
1-Gang Cover



**WMT7811-VN**

1-TOUCH PLATE  
1-Gang 1-Device



**WMT7812-VN**

1-TOUCH PLATE  
1-Gang Center 2-Device



**WMT507MYH-VN**

Switch "B", Single Pole  
1-Gang 4-Devices  
[Metallic Pearl Gray]  
10AX 250V~  
\*Applicable Wire: 1.5-2.5mm<sup>2</sup>  
[Solid and Stranded Wire Only]



**WMT502MYH-VN**

Switch "C", 3Way  
1-Gang 1-Device  
[Metallic Pearl Gray]  
16AX 250V~



**WMT504MYH-VN**

Switch "C", 3Way  
1-Gang 2-Devices  
[Metallic Pearl Gray]  
16AX 250V~



**WMT7813-VN**

1-TOUCH PLATE  
1-Gang 3-Device



**WMT6891MYZ-VN**

1-TOUCH PLATE  
1-Gang Cover  
[Metallic Pearl Gold]



**WMT7811MYZ-VN**

1-TOUCH PLATE  
1-Gang 1-Device  
[Metallic Pearl Gold]



**WMT506MYH-VN**

Switch "C", 3Way  
1-Gang 3-Devices  
[Metallic Pearl Gray]  
16AX 250V~



**WMT508MYH-VN**

Switch "C", 3Way  
1-Gang 4-Devices  
[Metallic Pearl Gray]  
10AX 250V~  
\*Applicable Wire: 1.5-2.5mm<sup>2</sup>  
[Solid and Stranded Wire Only]



**WMT594MYH-VN**

Switch "E", 4Way  
1-Gang 1-Device  
[Metallic Pearl Gray]  
10AX 250V~



**WMT7812MYZ-VN**

1-TOUCH PLATE  
1-Gang Center 2-Device  
[Metallic Pearl Gold]



**WMT7813MYZ-VN**

1-TOUCH PLATE  
1-Gang 3-Device  
[Metallic Pearl Gold]



**WMT6891MYH-VN**

1-TOUCH PLATE  
1-Gang Cover  
[Metallic Pearl Gray]



**WMT596MYH-VN**

Switch "E", 4Way  
1-Gang 2-Devices  
[Metallic Pearl Gray]  
10AX 250V~



**WMT707MYHK-VN**

Foot Light with Passive Infrared  
Sensor and Illuminance Sensor  
[Metallic Pearl Gray]  
\*Applicable Wire: 0.75-1.5mm<sup>2</sup>  
[Solid and Stranded Wire Only]



**WEC5781MYH-VN**

Electronic Key Card Switch  
[Metallic Pearl Gray]



**NEW**

**WMT7811MYH-VN**

1-TOUCH PLATE  
1-Gang 1-Device  
[Metallic Pearl Gray]



**WMT7812MYH-VN**

1-TOUCH PLATE  
1-Gang Center 2-Device  
[Metallic Pearl Gray]



**WMT7813MYH-VN**

1-TOUCH PLATE  
1-Gang 3-Device  
[Metallic Pearl Gray]



**WSBC7010MYH-VN**

Cable Outlet with 20A  
Terminal Block  
[Metallic Pearl Gray]  
\*Applicable Wire  
Input: 2.5-6.0mm<sup>2</sup>  
[Rigid Copper Wire]  
Output: 1.5-2.5mm<sup>2</sup>  
[Flexible Wire]



**NEW**

**WMT540108MYH-VN**

Bell Switch  
[Metallic Pearl Gray]



**NEW**

**WBC8981SW-VN**

Weatherproof Cover for  
BS-TYPE Switch Plastic IP43  
[White]



**WBC8991W-VN**

Weatherproof Cover for  
BS-TYPE Receptacle Plastic IP43  
[White]



HARMONY  
IN EVERY ANGLES

New slim designs to harmonize  
with any living space

Slimmer and easier-to-use setting the  
standard for advanced wiring device designs



■ **Designs in harmony with living spaces**

Simple and elegant design matches any room interior



■ **Always pleasant to the touch**

Advanced mechanism allows smoother ON/OFF switching. Designed for easiest possible operation



■ **Always reliable and beautiful**

Made of a material that resists color fading even when constantly bathed in room light or sunlight



**IP protection of Halumie**

Panasonic holds the rights of numerous patents and designs of the Halumie series in the Vietnam. The Halumie series is protected by the following design rights.



**Switches**



**Receptacles & Accessories**



**Dimmer Switches**



**Plates**



**Exclusive switch series with ultrathin panel and refined appearance adding elegance to your interior**

**FLAT PANEL WITH ULTRATHIN DESIGN**



- **Heat-resistant, easy-to-use latest switch mechanism**  
On/Off with just a soft push of the switch. Built for trouble-free operation

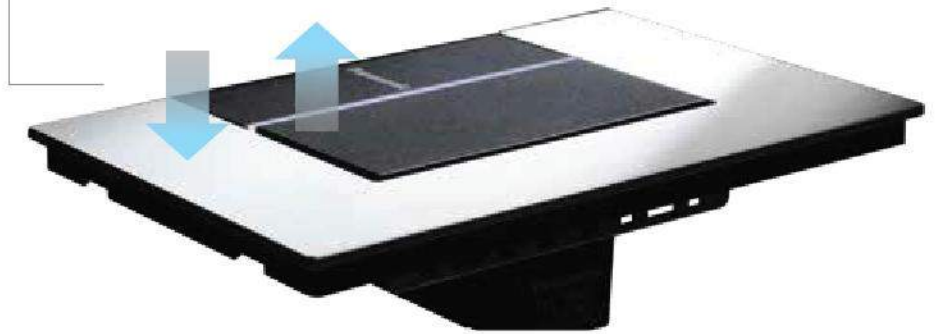

- **Sophisticated surface with a super-slim design**  
Ideal asymmetric design using 2mm-thick, high-quality aluminum plate



**Switches**

**WTEGP51552S-1-G**  
Illuminated Switch "C", 3Way  
1-Device with Plate  
16AX 250~  
(Neon Lamp: 220V~)



**WTEGP52562S-1-G**  
Illuminated Switch "C", 3Way  
2-Devices with Plate  
16AX 250~  
(Neon Lamp: 220V~)



**WTEGP53572S-1-G**  
Illuminated Switch "C", 3Way  
3-Devices with Plate  
16AX 250~  
(Neon Lamp: 220V~)



**EGG331**  
Weatherproof Push Button for Door Chime  
1A 220V~



**EGG335**  
Weatherproof Push Button for Door Chime  
1A 220V~  
(Dark Brown)



**EBG888**  
Door chime 220V~  
Two tone 9.5W, 50Hz.  
Easy-to-hear 82 dB Chime



**WTEGP54562S-1-G**  
Illuminated Switch "C", 3Way  
4-Devices with Plate  
16AX 250~  
(Neon Lamp: 220V~)



**WTEGP55582S-1-G**  
Illuminated Switch "C", 3Way  
5-Devices with Plate  
16AX 250~  
(Neon Lamp: 220V~)



**WTEGP56572S-1-G**  
Illuminated Switch "C", 3Way  
6-Devices with Plate  
16AX 250~  
(Neon Lamp: 220V~)



**Dimmer Switches**

**WEG57912B-1**  
Dimmer Switch  
(Incandescent and LED Light Control)  
200W(LED50W) 220-240V~  
※ Push On/Off Function Type



**WEG57813B-1-G**  
Dimmer Switch (Incandescent  
and Low Voltage Halogen with  
Transformer 12V Light Control)  
300W 220V~  
※ Off Function Type



**WEG57816B-1-G**  
Dimmer Switch (Incandescent  
and Low Voltage Halogen with  
Transformer 12V Light Control)  
500W 220V~  
※ Off Function Type



**WTFBP51552S-1-G**  
BS-TYPE Illuminated Switch "C", 3Way  
1-Device with Plate



**WTFBP52562S-1-G**  
BS-TYPE Illuminated Switch "C", 3Way  
2-Devices with Plate



**WTFBP53572S-1-G**  
BS-TYPE Illuminated Switch "C", 3Way  
3-Devices with Plate



**Plates**

**WTEG6503S-1-G**  
1-Gang 3-Device



**WTFB6503S-1-G**  
1-Gang 3-Device



**WTEG6506S-1-G**  
2-Gang 6-Device



**Receptacles and Accessories**

**WEG15829B-G**  
Grounding Duplex Universal Receptacle  
with Safety Shutter 16A 250~



**WEV2364B**  
Telephone Modular Jack (6P4C)



**WEV2488B**  
CAT5E Data Modular Jack



**WTEG6506S-G**  
2-Gang 6-Device



**WEV2501B**  
DIN Type Television Terminal



**WEG3020B-G**  
Blank Chip



**WEG1181BK-G**  
Grounding Universal Receptacle  
with Safety Shutter  
16A 250V~



**COLORFUL  
MULTI-STYLE**

## Wide color range suits modern interiors

Stylish color coordination enhancing your living environments

■ **Wide color palette to perfectly match lifestyle interiors**

Luxurious appearance with wide color variations creating attractive living spaces





**Various Combination: 8 Plate Colors × 8 Switch Colors**



The last 2 or 3 characters in of Refina product numbers show the item color.

**Switches**

<p><b>WEG5511</b> M H Switch "B", Single Pole 16AX 250V~</p>	<p><b>WEG5521</b> M H Switch "B", Single Pole 16AX 250V~</p>	<p><b>WEG5531</b> M H Switch "B", Single Pole 16AX 250V~</p>	<p><b>WEG5512</b> M H Switch "C", 3Way 16AX 250V~</p>
<p><b>WEG5522</b> M H Switch "C", 3Way 16AX 250V~</p>	<p><b>WEG5532</b> M H Switch "C", 3Way 16AX 250V~</p>	<p><b>WEG5551</b> M H Illuminated Switch "B", Single Pole 16AX 250V~ [Neon Lamp: 220V~]</p>	<p><b>WEG5561</b> M H Illuminated Switch "B", Single Pole 16AX 250V~ [Neon Lamp: 220V~]</p>
<p><b>WEG5571</b> M H Illuminated Switch "B", Single Pole 16AX 250V~ [Neon Lamp: 220V~]</p>	<p><b>WEG5552</b> M H Illuminated Switch "C", 3Way 16AX 250V~ [Neon Lamp: 220V~]</p>	<p><b>WEG5562</b> M H Illuminated Switch "C", 3Way 16AX 250V~ [Neon Lamp: 220V~]</p>	<p><b>WEG5572</b> M H Illuminated Switch "C", 3Way 16AX 250V~ [Neon Lamp: 220V~]</p>
<p><b>WEV5533-7SW</b> Glow Switch "D", Double Pole 20A 250V~</p>	<p><b>WEC5542-7SW</b> Twin Switch "C", 3Way 10AX 250V~</p>		

**Receptacles with Switches**

<p><b>WEGP1282</b> Grounding Duplex Universal Receptacle with Safety Shutter and Switch</p>			
<p>Metallic White <b>WEGP1282MW</b></p>	<p>Metallic Gray <b>WEGP1282MH</b></p>	<p>Metallic Brown <b>WEGP1282MF</b></p>	<p>Metallic Black <b>WEGP1282MB</b></p>
<p>Metallic White M W</p> <p>Metallic Pearl White M W Z</p>	<p>Metallic Gray M H</p> <p>Metallic Dark Brown M A</p>	<p>Metallic Brown M F</p> <p>Metallic Gold M Y</p>	<p>Metallic Black M B</p>
<p><b>WEV5511SW</b> Switch "B", Single Pole 16AX 250V~</p>	<p><b>WEV5521SW</b> Switch "B", Single Pole 16AX 250V~</p>	<p><b>WEV5531SW</b> Switch "B", Single Pole 16AX 250V~</p>	<p><b>WEV5512SW</b> Switch "C", 3Way 16AX 250V~</p>
<p><b>WEV5522SW</b> Switch "C", 3Way 16AX 250V~</p>	<p><b>WEV5532SW</b> Switch "C", 3Way 16AX 250V~</p>	<p><b>WEV5511-7SW</b> Switch "B", Single Pole 16AX 250V~</p>	<p><b>WEV5521-7SW</b> Switch "B", Single Pole 16AX 250V~</p>
<p><b>WEV5531-7SW</b> Switch "B", Single Pole 16AX 250V~</p>	<p><b>WEV5512-7SW</b> Switch "C", 3Way 16AX 250V~</p>	<p><b>WEV5522-7SW</b> Switch "C", 3Way 16AX 250V~</p>	<p><b>WEV5532-7SW</b> Switch "C", 3Way 16AX 250V~</p>

Receptacles

**WEV1081SW**  
Universal Receptacle with Safety Shutter  
16A 250V~



**WEV1091SW**  
Universal Receptacle  
16A 250V~



**WEG1001SW**  
Receptacle  
16A 250V~



**WEG1090SW**  
Round Pin Receptacle  
16A 250V~



**WEV1181SW**  
Grounding Universal Receptacle with Safety Shutter  
16A 250V~



**WEV1582SW**  
Grounding Duplex Universal Receptacle with Safety Shutter  
16A 250V~



**WEV1081-7SW**  
Universal Receptacle with Safety Shutter  
16A 250V~



**WEV1181-7SW**  
Grounding Universal Receptacle with Safety Shutter  
16A 250V~



Accessories

**WEV1582-7SW**  
Grounding Duplex Universal Receptacle with Safety Shutter  
16A 250V~



**WEF11721W8**  
2-port USB Charger 2A



**WEV24886SW**  
CAT6 Data Modular Jack



**WEV2488SW**  
CAT5E Data Modular Jack



Dimmer Switches

**WEV2364SW**  
Telephone Modular Jack (6P4C)



**WEV2501SW**  
DIN Type Television Terminal



**WEG57912SW**  
Dimmer Switch (Incandescent and LED Light Control)  
200W(LED50W) 220-240V~  
※ Push On/Off Function Type  
\*Applicable Wire: 1.0-4.0mm<sup>2</sup>  
(Solid, Stranded and Flexible Wire)



**WEF5791301SW-VN**  
Dimmer Switch with Minimum Brightness Adjustment (Incandescent and LED Light Control)  
100W(LED100W) 220V~  
※ Push On/Off Function Type



**WEF5791501SW-VN**  
Dimmer Switch with Minimum Brightness Adjustment (Incandescent and LED Light Control)  
240W(LED200W) 220V~  
※ Off Function Type



**EGG331**  
Weatherproof Push Button for Door Chime  
1A 220V



**EGG335**  
Weatherproof Push Button for Door Chime  
1A 220V~ (Dark Brown)



**EBG888**  
Door Chime  
220V~ Two Tone 9.5W, 50 Hz.  
Easy-to-Hear 82 dB Chime



Plates

FULL-COLOR WIDE SERIES Refina A-TYPE	Unit: mm									
	Plastic Plate 1-Gang 1-Device	Plastic Plate 1-Gang 2-Device	Plastic Plate 1-Gang 3-Device	Plastic Plate 1-Gang Center 2-Device	Plastic Plate 1-Gang Cover	Plastic Plate 2-Gang 4-Device Plate	Plastic Plate 2-Gang 6-Device Plate	Plastic Plate 1-Gang for HB Breaker	Plastic Plate 1-Gang for 1P1E MCB	Plastic Plate Double Cover Plate
Snow White [S][W]	WEV68010SW	WEV68020SW	WEV68030SW	WEV680290SW	WEV68910SW	WEV68040SW	WEV68060SW	WEV7061SW	WEV7001SW	WEV68920SW
Metallic Pearl White [M][W][Z]	WEG68010MWZ	WEG68020MWZ	WEG68030MWZ	WEG680290MWZ						
Metallic White [M][W]	WEV68010MW	WEV68020MW	WEV68030MW	WEV680290MW	WEV68910MW	WEV68040MW	WEV68060MW	WEV7061MW	WEV7001MW	
Metallic Gray [M][H]	WEV68010MH	WEV68020MH	WEV68030MH	WEV680290MH	WEV68910MH	WEV68040MH	WEV68060MH	WEV7061MH	WEV7001MH	
Metallic Black [M][B]	WEV68010MB	WEV68020MB	WEV68030MB	WEV680290MB	WEV68910MB	WEV68040MB	WEV68060MB	WEV7061MB	WEV7001MB	
Metallic Gold [M][Y]	WEG68010MY	WEG68020MY	WEG68030MY	WEG680290MY						
Metallic Brown [M][F]	WEG68010MF	WEG68020MF	WEG68030MF	WEG680290MF						
Metallic Dark Brown [M][A]	WEG68010MA	WEG68020MA	WEG68030MA	WEG680290MA						
<b>Weatherproof plates</b> 										
Metal IPX3	Metal WEG7801	Metal WEG7802	Metal WEG7803	Metal WEG7829						
Plastic IP55	Plastic WEG7901	Plastic WEG7902	Plastic WEG7903	Plastic WEG79029						
<b>Weatherproof cover plates (Horizontal Type)</b> 										
Metal IP55						Metal WEG8881-P				
Plastic IP55						Plastic WEG8981-P				

The last 2 or 3 characters [ ] in of Refina product number show the item color.  
\*IP=Ingress Protection (when flap is closed).

**Receptacles and Accesories**

**WEV1081-7H**  
Universal Receptacle  
with Safety Shutter  
16A 250V~  
**WEB7811** **M** **W** (Plate)  
1-Gang 1-Device



★

**WEV1081H**  
Universal Receptacle  
with Safety Shutter  
16A 250V~  
**WEB7812** **M** **W** (Plate)  
1-Gang 2-Devices

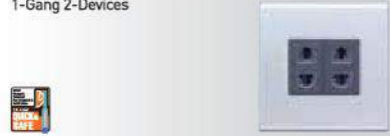

**WEV1181H**  
Grounding Universal Receptacle  
with Safety Shutter  
16A 250V~  
**WEB7812** **M** **W** (Plate)  
1-Gang 2-Devices



**WEV1081-7SW**  
Universal Receptacle with  
Safety Shutter 16A 250V~  
**WEV5531-7SW**  
1Way SP Switch "B" 16AX 250V~  
**WEB7812SW** (Plate)  
1-Gang 2-Devices



★

**WEV2501SW**  
DIN Type Television Terminal  
**WEV2364SW**  
Telephone Modular Jack (6P4C)  
**WEB7812SW** (Plate)  
1-Gang 2-Devices

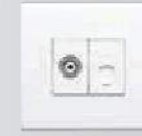

**WEV2501SW**  
DIN Type Television Terminal  
**WEB7811SW** (Plate)  
1-Gang 1-Device



**WEV1582-7H**  
Grounding Duplex Universal  
Receptacle with Safety Shutter  
16A 250V~  
**WEB7813** **M** **W** (Plate)  
1-Gang 3-Devices



★

**WEV1191H**  
Grounding Universal Receptacle  
16A 250V~  
**WEG5151-51HK**  
Illuminated Switch "B", Single Pole  
16AX 250V~ (Neon Lamp 220V~)  
**WEB7813** **M** **W** (Plate)  
1-Gang 3-Devices

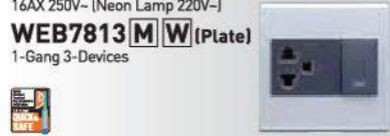

**WEV2501H**  
DIN Type Television Terminal  
16A 250V~  
**WEV2364H**  
Telephone Modular Jack (6P4C)  
**WEB7812** **M** **W** (Plate)  
1-Gang 2-Devices

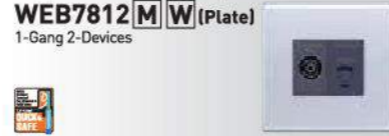

**WEV2488SW**  
CAT5E Data Modular Jack  
**WEB7811SW** (Plate)  
1-Gang 1-Device



**WEV24886SW**  
CAT6 Data Modular Jack  
**WEB7811SW** (Plate)  
1-Gang 1-Device



**WEV2364SW**  
Telephone Modular Jack (6P4C)  
**WEV2488SW**  
CAT5E Data Modular Jack  
**WEB7812SW** (Plate)  
1-Gang 2-Devices



**WEV2501H**  
DIN Type Television Terminal  
**WEB7811** **M** **W** (Plate)  
1-Gang 1-Device



**WEV2364H**  
Telephone Modular Jack (6P4C)  
**WEB7811** **M** **W** (Plate)  
1-Gang 1-Device



**WEV2488H**  
CAT5E Data Modular Jack  
**WEB7811** **M** **W** (Plate)  
1-Gang 1-Device



**WEG575181**  
Dimmer Switch  
(Incandescent Light Control)  
800W 220V~  
**WEB7812SW** (Plate)  
1-Gang 2-Devices



**WEG5151-51SWK**  
Illuminated Switch "B" Single Pole  
**WEB7811SW** (Plate)  
1-Gang 1-Device

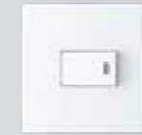

**WEV5001-7SW**  
Switch "B" Single Pole  
16AX 250V~  
**WEB7813SW** (Plate)  
1-Gang 3-Devices

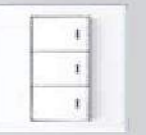

★

**WEV24886H**  
CAT6 Data Modular Jack  
**WEB7811** **M** **W** (Plate)  
1-Gang 1-Device



**WEG575181H**  
Dimmer Switch  
(Incandescent Light Control)  
800W 220V~  
**WEB7812** **M** **W** (Plate)  
1-Gang 2-Devices



**WEV1081-7SW**  
Universal Receptacle with  
Safety Shutter  
16A 250V~  
**WEB7811SW** (Plate)  
1-Gang 1-Device



★

**WEG5401-7SW**  
Push Bottom "B" Single Pole  
10A 250V~  
**WEB7811SW** (Plate)  
1-Gang 1-Device



**WEBP1041SW-P**  
1-Gang multiple Receptacle



**WBC8981SW-VN**  
Weatherproof Cover  
for BS-TYPE Switch Plastic IP43  
(White)



**WEV1081-7SW**  
Universal Receptacle with  
Safety Shutter  
16A 250V~  
**WEB7812SW** (Plate)  
1-Gang 2-Devices



★

**WEV1081-7SW**  
Universal Receptacle with  
Safety Shutter 16A 250V~  
**WEV1181-7SW**  
Grounding Universal Receptacle with  
Safety Shutter 16A 250V~  
**WEB7813SW** (Plate)  
1-Gang 3-Devices

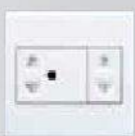

★

**WEV1582-7SW**  
Grounding Duplex Universal  
Receptacle with Safety Shutter  
16A 250V~  
**WEB7813SW** (Plate)  
1-Gang 3-Devices



★

**WBC8991W-VN**  
Weatherproof Cover  
for BS-TYPE Receptacle Plastic IP43  
(White)



**WSBC7010SW-VN**  
Cable Outlet with 20A  
Terminal Block  
\*Applicable Wire  
Input: 2.5-6.0mm<sup>2</sup>  
(Rigid Copper Wire)  
Output: 1.5-2.5mm<sup>2</sup>  
(Flexible Wire)

















NEW

**WEBFP57311W-VN**  
Passive Infrared Sensor with Plate  
(Wall Flush Mount)

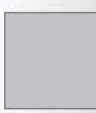

NEW





Switches with plate [Pillar terminal]

COLOR	 1-Device 1Way SP Switch "B" 16AX 250V~ ★	 2-Devices 1Way SP Switch "B" 16AX 250V~ ★	 3-Devices 1Way SP Switch "B" 16AX 250V~ ★	 1-Device 2Way SP Switch "C" 16AX 250V~ ★	 2-Devices 2Way SP Switch "C" 16AX 250V~ ★	 3-Devices 2Way SP Switch "C" 16AX 250V~ ★
 Snow White [S][W]	WEBP515117SW	WEBP525217SW	WEBP535317SW	WEBP515127SW	WEBP525227SW	WEBP535327SW
 Metallic Pearl White [M][W][Z]	WEBP515117MWZ	WEBP525217MWZ	WEBP535317MWZ	WEBP515127MWZ	WEBP525227MWZ	WEBP535327MWZ
 Metallic White [M][W]	WEBP515117MW	WEBP525217MW	WEBP535317MW	WEBP515127MW	WEBP525227MW	WEBP535327MW
 Metallic Gray [M][H]	WEBP515117MH	WEBP525217MH	WEBP535317MH	WEBP515127MH	WEBP525227MH	WEBP535327MH
 Metallic Black [M][B]	WEBP515117MB	WEBP525217MB	WEBP535317MB	WEBP515127MB	WEBP525227MB	WEBP535327MB
 Metallic Gold [M][Y]	WEBP515117MY	WEBP525217MY	WEBP535317MY	WEBP515127MY	WEBP525227MY	WEBP535327MY
 Metallic Brown [M][F]	WEBP515117MF	WEBP525217MF	WEBP535317MF	WEBP515127MF	WEBP525227MF	WEBP535327MF
 Metallic Dark Brown [M][A]	WEBP515117MA	WEBP525217MA	WEBP535317MA	WEBP515127MA	WEBP525227MA	WEBP535327MA

The last 2 or 3 characters in of Refina product numbers show the item color.

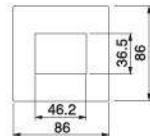
Plates

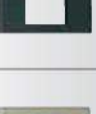
Unit: mm

FULL-COLOR WIDE SERIES Refina BS-TYPE 	 1-Gang 1-Device	 1-Gang 2-Device	 1-Gang 3-Device
 Snow White [S][W]	WEB7811SW	WEB7812SW	WEB7813SW
 Metallic Pearl White [M][W][Z]	WEB7811MWZ	WEB7812MWZ	WEB7813MWZ
 Metallic White [M][W]	WEB7811MW	WEB7812MW	WEB7813MW
 Metallic Gray [M][H]	WEB7811MH	WEB7812MH	WEB7813MH
 Metallic Black [M][B]	WEB7811MB	WEB7812MB	WEB7813MB
 Metallic Gold [M][Y]	WEB7811MY	WEB7812MY	WEB7813MY
 Metallic Brown [M][F]	WEB7811MF	WEB7812MF	WEB7813MF
 Metallic Dark Brown [M][A]	WEB7811MA	WEB7812MA	WEB7813MA
 Weatherproof cover plates (Horizontal Type) Plastic IP55			WEG8981-P

The last 2 or 3 characters in of Refina product numbers show the item color.

THE **STANDARD** OF  
YOUR COMFORTABLE LIFE

## The beauty of simplicity

Sharp looking design brings a polished touch to your living room and office

### ■ Elegantly simple squarish design

Add a refreshing accent to any room. Bold, modern plates with square shapes available in various configurations to suit residential and commercial requirements

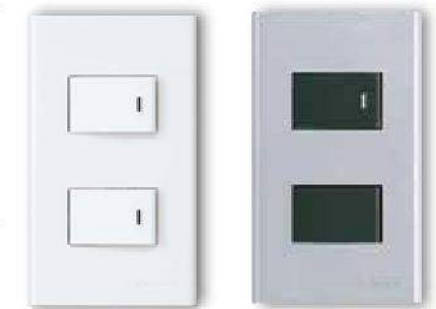
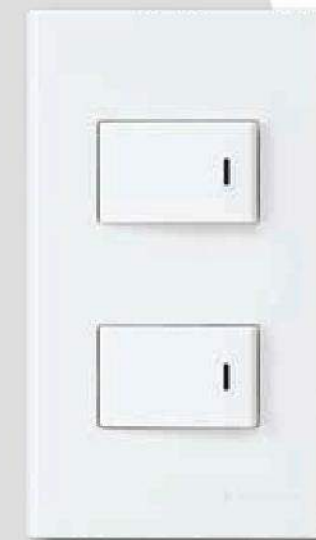

### ■ Heat-resistant, easy-to-use Latest switch mechanism

Panasonic's standard design wiring device with simple, trouble-free switch mechanism

**Switches**

**WEV5001SW**  
Switch "B", Single Pole  
16AX 250V~



**WEG5151-51SWK**  
Illuminated Switch "B", Single Pole  
16AX 250V (Neon Lamp: 220V~)



**WEG5141SW**  
Glow Switch "B", Single Pole  
2 Wire 6AX 250V~



**WEV5001-7SW**  
Switch "B", Single Pole  
16AX 250V~



**WEV1081-7SW**  
Universal Receptacle with Safety Shutter  
16A 250V~



**WEV1091SW**  
Universal Receptacle  
16A 250V~



**WEG1001SW**  
Receptacle  
16A 250V~



**WEG1090SW**  
Round Pin Receptacle  
16A 250V~

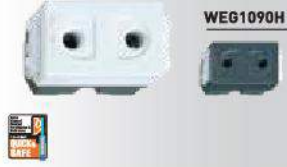

**WEG51517SW**  
Illuminated Switch "B", Single Pole  
16AX 250V~ (Neon Lamp: 220V~)



**WEV5002SW**  
Switch "C", 3Way  
16AX 250V~



**WEG5152-51SWK**  
Illuminated Switch "C", 3Way  
16AX 250V~ (Neon Lamp: 220V~)



**WEV5002-7SW**  
Switch "C", 3Way  
16AX 250V~



**WEV1181SW**  
Grounding Universal Receptacle  
with Safety Shutter  
16A 250V~



**WEV1181-7SW**  
Grounding Universal Receptacle  
with Safety Shutter  
16A 250V~



**WEV1582SW**  
Grounding Duplex Universal  
Receptacle with Safety Shutter  
16A 250V~



**WEV1582-7SW**  
Grounding Duplex Universal  
Receptacle with Safety Shutter  
16A 250V~



**WEG51527SW**  
Illuminated Switch "C", 3Way  
16AX 250V~ (Neon Lamp: 220V~)



**WEG5003KSW**  
Switch "D", Double Pole  
16AX 250V~



**WEG5004KSW**  
Switch "E", 4Way  
16AX 250V~



**WEG5341SW**  
Glow Switch "B", Single Pole 3 Wire  
16A 250V~



**WEV24886SW**  
CAT6 Data Modular Jack



**WEV2488SW**  
CAT5E Data Modular Jack



**WEV2364SW**  
Telephone Modular Jack  
(6P4C)



**WEV2501SW**  
DIN Type Television Terminal



**Receptacles and Accessories**

**WEV5033-7SW**  
Glow Switch (2 poles)  
20A 250V~



**WEG3032GSW (Green)**  
Pilot Lamp  
220V~



**WEG3032SW (White)**  
Pilot Lamp  
220V~



**WEG3032RSW (Red)**  
Pilot Lamp  
220V~



**WEG5401-7SW**  
Push Button "B" Single Pole  
10A 250V~



**WEGP1041SW-1**  
1-Gang multiple Receptacle  
16A 250V~



**WEF11721W8** NEW  
2-port USB Charger 2A



**WEF11821W** NEW  
2-port USB Fast Charger 3A



**WEG5400-7**  
Push Button NC Contact Type  
10A 250V~



**WEG3023SW**  
Telephone Wire Chip  
for 9mm Diameter 16 Diameter



**WEG3020SW**  
Blank Chip



**WEV1081SW**  
Universal Receptacle with Safety Shutter  
16A 250V~



**EGG331**  
Weatherproof Push Button for Door Chime  
1A 220V~



**EGG335**  
Weatherproof Push Button for Door Chime  
1A 220V~  
(Dark Brown)



**EBG888**  
Door Chime  
220V~ Two Tone 9.5W, 50 Hz.  
Easy-to-Hear  
82 dB Chime



**Dimmer Switches**

**WEF5791301SW-VN** NEW  
Dimmer Switch with Minimum Brightness Adjustment (Incandescent and LED Light Control) 100W(LED100W) 220V~  
※ Push On/Off Function Type

**WEF5791501SW-VN** NEW  
Dimmer Switch with Minimum Brightness Adjustment (Incandescent and LED Light Control) 240W(LED200W) 220V~  
※ Push On/Off Function Type

**WEG575151SW**  
Dimmer Switch (Incandescent Light Control) 500W 220V~  
※ Off Function Type  
\*Applicable Wire: 1.0-2.5mm<sup>2</sup> (Solid Wire Only)

**WEG575181**  
Dimmer Switch (Incandescent Light Control) 800W 220V~  
※ Off Function Type  
\*Applicable Wire: 1.0-2.5mm<sup>2</sup> (Solid Wire Only)

**For Hotel**

**WEG57912SW**  
Dimmer Switch (Incandescent and LED Light Control) 200W(LED50W) 220-240V~  
※ Push On/Off Function Type  
\*Applicable Wire: 1.0-4.0mm<sup>2</sup> (Solid, Stranded and Flexible Wire)

**WSBC9120SW-VN** NEW  
Shaver Receptacle Input 220V-240V~ Output 230V/115V~

**WEC5781W-VN**  
Electronic Key Card Switch

**WEG5001SWK-031**  
Hotel Use Switch "B" for Indication "Make up Room" 16AX 250V~

**WEG5401-011SW**  
Entrance Bell 10A 250V~

**WEG5002SWK-021**  
Hotel Use Switch "C" for Indication "Don't Disturb" 16AX 250V~

**WEG3032G-031**  
Pilot Lamp for Indication "Make up Room" Green 220V~

**WEG3032R-021**  
Pilot Lamp for Indication "Don't Disturb" Red 220V~

**Wiring diagram - "Don't Disturb" - "Make up Room" - "Bell Switch"**

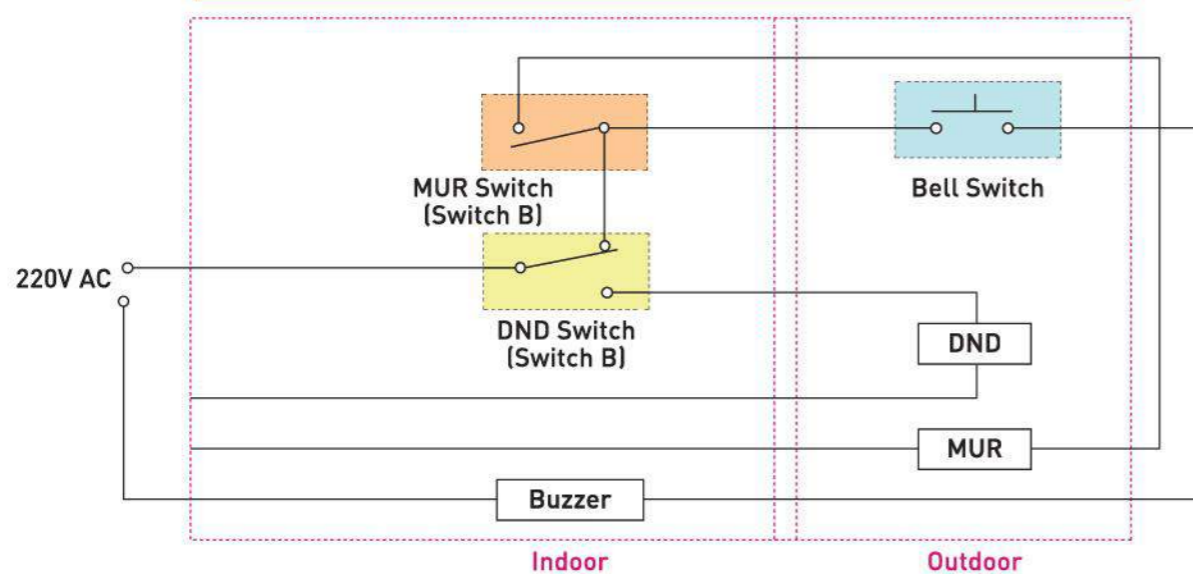

**Plates**

	Unit: mm									
<b>FULL-COLOR WIDE SERIES</b>										
<b>Standard plate</b>	WEV68010SW	WEV68020SW	WEV68030SW	WEV680290SW	WEV68910SW	WEV68040SW	WEV68060SW	WEV7061SW	WEV7001SW	WEV68920SW
<b>Metal plate</b>	WEV6501-1	WEV6502-1	WEV6503-1	WEV65029-1	WEV6591-1					
<b>Metallic</b>	WEV68010MWZ	WEV68020MWZ	WEV68030MWZ	WEV680290MWZ						
Metallic Pearl White	WEV68010MW	WEV68020MW	WEV68030MW	WEV680290MW	WEV68910MW	WEV68040MW	WEV68060MW	WEV7061MW	WEV7001MW	
Metallic White										
Metallic Gray	WEV68010MH	WEV68020MH	WEV68030MH	WEV680290MH	WEV68910MH	WEV68040MH	WEV68060MH	WEV7061MH	WEV7001MH	
Metallic Black										
Metallic Gold	WEV68010MY	WEV68020MY	WEV68030MY	WEV680290MY						
Metallic Brown	WEV68010MF	WEV68020MF	WEV68030MF	WEV680290MF						
Metallic Dark Brown	WEV68010MA	WEV68020MA	WEV68030MA	WEV680290MA						
<b>Weatherproof plates</b>	Metal WEG7801	Metal WEG7802	Metal WEG7803	Metal WEG78029						
Plastic WEG7901	Plastic WEG7902	Plastic WEG7903	Plastic WEG79029							
<b>Weatherproof cover plates (Horizontal Type)</b>										
Metal WEG8881-P										
Plastic WEG8981-P										

\*IP=Ingress Protection (when flap is closed).

# FULL-COLOR SERIES

## The standard of excellence for any installation

Simple design compatible with any interior plan

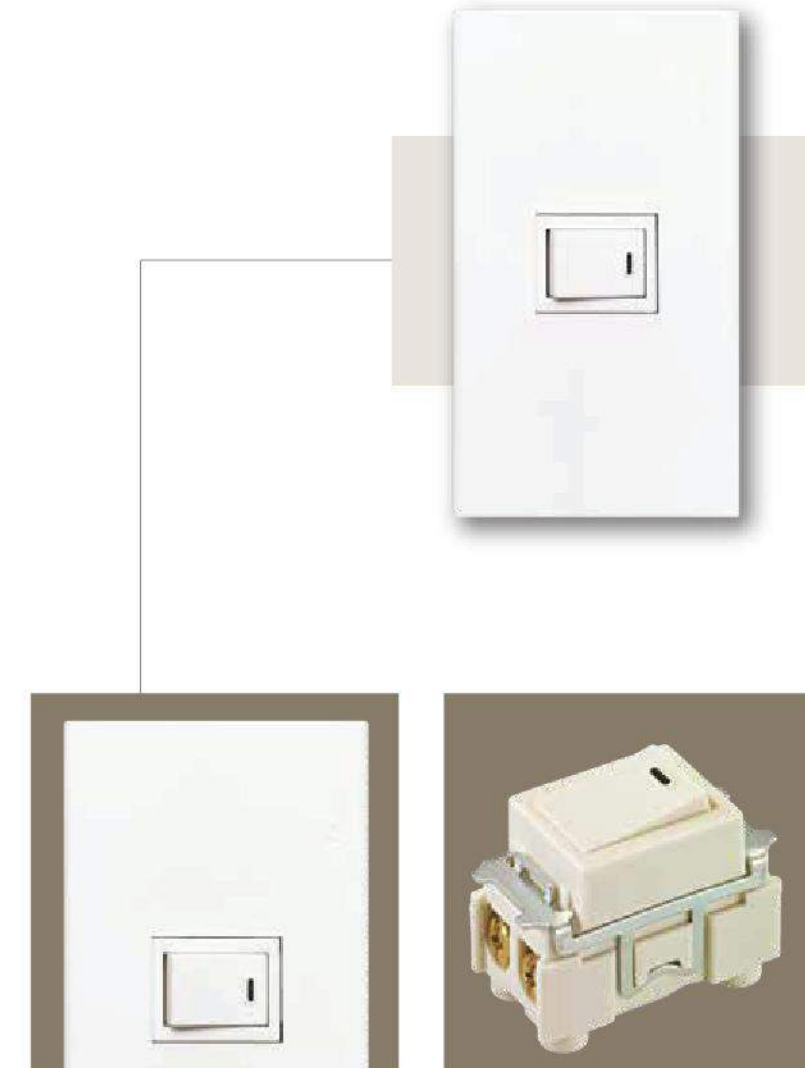

- **Heat-resistant, easy-to-use latest switch mechanism**  
A basic Panasonic wiring device with simple, trouble-free switch mechanism



**Switches**

**WNV5001-7W**

Switch "B", Single Pole  
16AX 250V~



**WNG5061W-701**

Appellation Switch "B", Single Pole  
16AX 250V~



**WNG5021W-7**

Twin Switch "B", Single Pole  
10AX 250V~



**WN5241W-801**

Appellation Glow  
Switch "B", Single Pole  
4A 300V~



**WNG5051W-751**

Illuminated Appellation  
Switch "B", Single Pole  
16AX 250V~  
(Neon Lamp: 220V~)



**WNG5401W-7K**

Push Button "B", Single Pole  
10A 300V~



**WSG3001**

Surface Mounting  
Switch "B", Single Pole  
10A 300V~



**WNV5002-7W**

Switch "C", 3Way  
16AX-250V~



**WNG5052W-751**

Illuminated Appellation  
Switch "C", 3Way  
16AX 250V~  
(Neon Lamp: 220V~)



**WNG5003W-7**

Switch "D", Double Pole  
10AX 250V~



**WNG5343W-761**

Glow Switch "D", Double Pole  
for Water Heater  
20AX 250V~



**WBG5414699W-SP**

Glow Switch "D", Double Pole  
20AX 250V~



**WBG5414699W**

Glow Switch "D", Double Pole  
for A/C  
20AX 250V~



**WNG5004W-7**

Switch "E", 4Way  
10AX 250V~



**WNH5611-801**

Tablet Switch  
10A 250V~



**Dimmer Switches**

**WNGP575152W**

Dimmer Switch with  
Blank Chip and Modern Plate  
(Incandescent Light Control)  
500W 220-240V~



**WNGP575283W**

Dimmer Switch with  
Modern Plate  
(Incandescent Light Control)  
800W 220-240V~



**Receptacles and Accessories**

**WNV1081-7W**

Universal Receptacle with  
Safety Shutter  
16A 250V~



**WNV1091-7W**

Universal Receptacle  
10A 250V~



**WN1090-7K-W**

Round Pin Receptacle  
10A 250V~



**WN1001-7K-W**

Receptacle  
10A 250V~



**WN1101-7W**

3 Wire Grounding Receptacle  
10A 250V~



**WNG15923-7W**

Grounding Duplex Universal  
Receptacle  
16A 250V~



**NR3170W-8**

CAT6 Data Modular Jack



**NRV3160W**

Enhanced CAT5E Data Modular Jack



**WNTG15649W**

Telephone Modular Jack  
(6P4C)



**WZV1201W**

Television Terminal  
(Current Passing Type)



**WN3020W**

Blank Chip



**WN3023W**

Telephone Wire Chip



**WKG1092-250**

Surface Mounting Universal  
Duplex Receptacle  
10A 250V~



**WKG1091-250**

Surface Mounting Universal  
Receptacle  
10A 250V~





Plates

Unit: mm

FULL-COLOR SERIES A-TYPE	Modern Plate	Aluminum Plate		Stainless Plate
		Screw Visible		Screw Visible
		Without Mounting Strap	With Mounting Strap	With Mounting Strap
	1-Gang 1-Device WZV7841W	WN7501-8	WN65019-8	WN7601-8
	1-Gang 2-Device WZV7842W	WN7502-8	WN65029-8	WN7602-8
	1-Gang 3-Device WZV7843W	WN7503-8	WN65039-8	WN7603-8
	2-Gang 4-Device WZV7844W	WN7504-8	WN6504K-8	WN7604-8
	2-Gang 6-Device WZV7846W	WN7506-8	WN6506K-8	WN7606-8
	1-Gang Cover	-	-	WN7691-8
	1-Gang for HB WZV7061W	-	-	-

Weather Proof Plates IPX3	Dimensions (mm)				
	Metal	WN7801K-8	WN7802K-8	WN7803K-8	WN7821K-8
		Metal	WN7901-8	WN7902-8	WN7903-8
		Plastic	WN7901-8	WN7902-8	WN7921-8

\*IP=Ingress Protection (when flap is closed).

Locking Receptacles and Weather Proof Locking Receptacles

Form	Rating	Locking Flush Mounting Receptacles		Locking Surface Mounting Receptacles		Weather Proof Locking Receptacles (JIS Weather Proof Type)	Applicable Electrical Wire
		Black	Milky White	Black	Milky White		
2P	15A 125V	WF2215BK	WF2215WK	WK2215	WK2215W	-	Ø1.6, Ø2 2mm <sup>2</sup> , 3.5mm <sup>2</sup>
	20A 250V	WF2220BK*1	WF2220WK*1	WK2220K	-	-	Ø2, Ø2.6 3.5mm <sup>2</sup> , 5.5mm <sup>2</sup>
3P	20A 250V	WF2320BK*1	WF2320WK*1	WK2320K	WK2320W	WK6320	Ø2, Ø2.6 3.5mm <sup>2</sup> , 5.5mm <sup>2</sup>
	30A 250V	WF2331B*1	WF2331W*1	WK2331B	WK2331W	WK6331	Ø2.6, Ø3.2 5.5mm <sup>2</sup> , 8mm <sup>2</sup>
	60A 250V	WF2360B	WF2360W	-	-	-	8mm <sup>2</sup> , 14mm <sup>2</sup>
Grounding 2P (Previously 3P)	15A 125V	WF2315BK	WF2315WK	WK2315K	WK2315W	WK6315	Ø1.6, Ø2 2mm <sup>2</sup> , 3.5mm <sup>2</sup>
	20A (L6-20) 250V	WF2520B*1	WF2520W*1	WK2520B	WK2520W	WK6520	Ø2, Ø2.6 3.5mm <sup>2</sup> , 5.5mm <sup>2</sup>
	30A (L6-30) 250V	WF2330B*1	WF2330W*1	WK2330	WK2330W	WK6330	Ø2.6, Ø3.2 5.5mm <sup>2</sup> , 8mm <sup>2</sup>
Grounding 3P (Previously 4P)	20A 250V	WF2420BK*1	WF2420WK*1	WK2420K	-	WK6420	Ø2, Ø2.6 3.5mm <sup>2</sup> , 5.5mm <sup>2</sup>
	30A (L15-30) 250V	WF2430B*1	WF2430W*1	WK2430	-	WK6430	Ø2.6, Ø3.2 5.5mm <sup>2</sup> , 8mm <sup>2</sup>
	60A 250V	WF2460B	WF2460W	-	-	-	8mm <sup>2</sup> , 14mm <sup>2</sup>

\* The 3P 30A and the grounding 3P 30A receptacles conform to NEMA standards and are not exchangeable with some of the receptacles used domestically in Japan.  
 \*\* "Multi-Level Weather Proof Valve" is adopted.  
 Numbers indicated by a [ ] mark are the NEMA standard number.

**Features**

The Japan Electric Association Code has been revised (8001-1990), with the distinction between grounding poles and grounded-side pins clearly identified. In addition, although not stipulated in the Japan Electric Association Code, these receptacles have been established by the standards of the Japan Wiring Devices Association.

**Explanation of The Revisions (Related Sections)**

Revisions in The Internal Wiring Standards	Before Revision	After Revision	Standards of The Japan Association of Wiring Fixture Manufacturers*1	Our Previous Product	Newly Established
	20A				30A

The diagram above is indicating the face of receptacles.

Pole arrangements which are not stipulated in the Japan Electric Association Code are selected according to the standards of the Japan Wiring Devices Association.

**Dimensions (Unit: mm)**

• Locking Flush Mounting Receptacles

• Locking Surface Mounting Receptacle

• Weather Proof Locking Receptacle

Model No.	Dimension A
3P	WK6320 34.5
	WK6331 40.5
Grounding 2P (Previously 3P)	WK6315 34.5
	WK6520 34.5
	WK6330 40.5
Grounding 3P (Previously 4P)	WK6420 40.5
	WK6430 40.5

All products have entirely the same specifications as those sold in Japan.

Locking Weather Proof Rubber Cord Connectors, Plugs, Bodies, Locking Plugs, and Locking Cord Connectors

Applicable Wire Types: Rubber Cabtire Cable (Type 2 or less), Round Rubber Cabtire Cord, Vinyl Cabtire Cable, and Round Vinyl Cabtire Cord

Locking Plugs		Tough Plugs		Flush Cord Locking Corner Plugs "Horizontal Type"		Applicable Electrical Wire	Locking Water Proof Rubber Cord Connector Plugs and Cord Connector Bodies (JIS Weather Proof Type)			
WF6420		WF62153B		WF3424			Plug WF8420K	Body WA5429K	Set WA5420K	Multi-Level Weather Proof Valve Improves cord insertability without losing weatherproofing performance.
Black	Milky White	Black	Milky White	Plugs "Horizontal Type"		Plugs	Bodies	Set	Applicable Electrical Wire's Outer Diameter (Ø)	
WF6215	WF6215W	-	-	-	-	1.25mm <sup>2</sup> 2mm <sup>2</sup>	WF8215K ★★	WA5219K ★★	WA5215K ★★	9.6-12
-	-	WF62153B	WF62153W	-	-	1.25mm <sup>2</sup> 2mm <sup>2</sup> -5mm <sup>2</sup>	-	-	-	-
WF6220	WF6220W	-	-	-	-	2mm <sup>2</sup> 3.5mm <sup>2</sup>	WF8220K ★★	WA5229K	WA5220K	10.5-13.5
WF6320	WF6320W	-	-	-	-	2mm <sup>2</sup> 3.5mm <sup>2</sup>	WF8320K ★★	WA5329K ★★	WA5320K ★★	11-14.5
-	-	-	-	WF3324a (Horizontal Type)		-	-	-	-	-
WF6331B	WF6331W	-	-	-	-	3.5mm <sup>2</sup> 5.5mm <sup>2</sup>	WF8331 ★★ ★(L11-30)	WA5338 ★★ ★(L11-30)	WA5331 ★★ ★(L11-30)	13-16
-	-	-	-	-	-	8mm <sup>2</sup> 14mm <sup>2</sup>	WF8360	WA5369	WA5360	17.5-22
WF6315	WF6315W	-	-	-	-	1.25mm <sup>2</sup> 2mm <sup>2</sup>	WF8315K ★★	WA5319K ★★	WA5315K ★★	10.5-13
-	-	WF3315B	WF3315W	WF3314 (Horizontal Type)		-	-	-	-	-
-	-	-	-	WF3524 (Horizontal Type)		2mm <sup>2</sup> 3.5mm <sup>2</sup>	WF8520 ★★	WA5529 ★★	WA5520 ★★	11-14.5
WF6330	WF6330W	-	-	-	-	3.5mm <sup>2</sup> 5.5mm <sup>2</sup>	WF8330	WA5339	WA5330	13-16
-	-	-	-	WF3334 (Horizontal Type)		-	-	-	-	-
WF6420	WF6420W	-	-	-	-	2mm <sup>2</sup> 3.5mm <sup>2</sup>	WF8420K ★★	WA5429K ★★	WA5420K ★★	12-16
-	-	-	-	WF3424 (Horizontal Type)		-	-	-	-	-
WF6430	WF6430W	-	-	-	-	3.5mm <sup>2</sup> 5.5mm <sup>2</sup>	WF8430	WA5439	WA5430	14-17.5
-	-	-	-	WF3434 (Horizontal Type)		-	-	-	-	-
-	-	-	-	-	-	8mm <sup>2</sup> 14mm <sup>2</sup>	WF8460	WA5469	WA5460	19.5-24

Note: • For outdoor wiring exposed to rain, use either rubber cabtire cable or vinyl cabtire cable.  
• For indoor locations exposed to moisture or high humidity, use rubber cabtire cable.  
• If you use stranded wire on screw terminal, please don't solder up the copper wires at the surface.  
There is a possibility that heating will occur since long time use may bring about oxidizing on surface of solder and make the contact between terminal and solder defective.

Features

Locking corner plugs are suitable for large kitchen equipment and other electrical equipment.

- Horizontal type can make electrical code line compact.
- Even in the narrow space, you can arrange equipment in order.

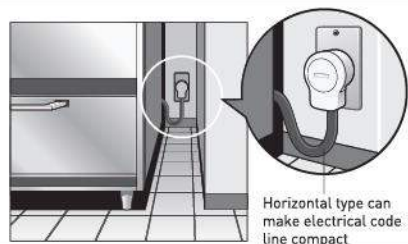

Horizontal type can make electrical code line compact.

For the connection of the power supply to electrical equipment in factories, etc. 2P 15A locking weatherproof rubber cord connector. (Locking flat plugs + weatherproof constructoin + compact size)



Applicable Wire: 1.25 - 2mm<sup>2</sup>  
(Outer Diameter: 9.6 - 12mm)

WF8715  
2P 15A Locking weatherproof rubber plug 15A 125V



WA6219  
2P 15A Locking weatherproof rubber cord connector body 15A 125V



WA6215  
2P 15A Locking weatherproof rubber cord connector (set) 15A 125V

Locking Plugs

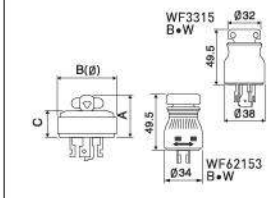

Model No.	Dimension A	Dimension B	Dimension C
2P WF6215-W	34	34	19
WF6220	36	41	21
WF6320	38	46	23
WF631B	57.5	62.5	44
WF6315-W	36	38.5	21
Grounding 2P (Previously 2P) WF3315B-W	49.5	38	-
WF6330-W	57.5	62.5	44
Grounding 3P (Previously 3P) WF6420-W	40	56	25
WF6430-W	57.5	62.5	44

Flush Cord Locking Corner Plugs "Horizontal Type"

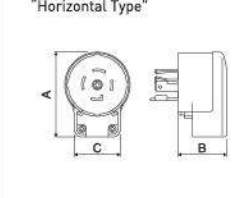

Model No.	Dimension A	Dimension B	Dimension C
Grounding 2P (Previously 2P) WF3314	52	32	38
WF3324	63	37	46
3P WF3324	73.25	43	56.5
Grounding 3P (Previously 3P) WF3424	73.25	43	56.5
WF3434	73.25	43	56.5

Locking Water Proof Rubber Plugs

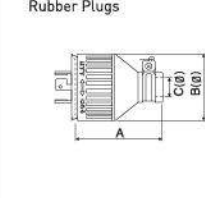

Model No.	Dimension A	Dimension B	Dimension C
2P WF8215K	62	41	12
WF8220K	66	47.2	13.5
WF8320K	68.8	53	14.5
3P WF8331	93.5	69.5	16
WF8360	178	80.5	22
Grounding 2P (Previously 2P) WF8315K	64.5	46	13.5
WF8520	78.2	46	14.5
WF8330	93.5	69.5	16
Grounding 2P (Previously 2P) WF8420K	79	63.6	16
WF8430	93.5	69.5	17.5
Grounding 3P (Previously 3P) WF8460	178	80.5	24

Locking Water Proof Rubber Bodies

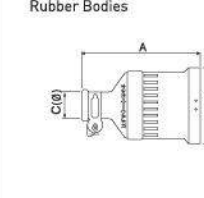

Model No.	Dimension A	Dimension B	Dimension C
2P WA5219K	89	44	12
WA5229K	98	51.5	13.5
WA5329K	103.5	56.5	14.5
3P WA5338	118.5	74.5	16
WA5369	171.5	74	22
Grounding 2P (Previously 2P) WA5319K	97	49	13
WA5529	112	53.5	14.5
WA5339	118.5	74.5	16
Grounding 2P (Previously 2P) WA5429K	112	67.5	16
WA5439	118.5	74.5	17.5
Grounding 3P (Previously 3P) WA5469	171.5	74	24

Locking Water Proof Rubber Cord Connectors (Complete Set)

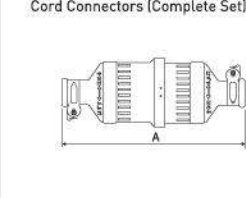

Model No.	Dimension A
2P WA5215K	148.5
WA5220K	161
WA5320K	169.1
3P WA5331	208.5
WA5360	320
Grounding 2P (Previously 2P) WA5315K	159
WA5520	183.8
WA5330	208.5
Grounding 2P (Previously 2P) WA5420K	187.5
WA5430	208.5
Grounding 3P (Previously 3P) WA5460	320

All products have entirely the same specifications as those sold in Japan.

High-Capacity Flush Mounting Receptacles, Surface Mounting Receptacles, Plugs, Tough Plugs, and Cord Connectors

Applicable Wire Types: Rubber Cabtire Cable (Type 2 or less), Round Rubber Cabtire Cord, Vinyl Cabtire Cable, and Round Vinyl Cabtire Cord

Note	Flush Mounting Receptacles		Surface Mounting Receptacles		Applicable Electrical Wire	Plugs		Tough Plugs		Plugs "Horizontal Type"		Applicable Electrical Wire
	Form	Rating	Black	Milky White		Black	Milky White	Black	Milky White	Black	Milky White	
Note: For models (WF1220BK/WK, WF1230BK/WK, WF1320BK/WK, WF1420BK/WK) indicated by a ※ mark, due to the size of the plugs, no more than one plug can be plugged in at the same time if the receptacles are installed in a multi-receptacle switch box. Therefore, if two or more circuits are to be used at the same time, use single switch boxes and install the number needed.	WF1220BK	WF1220W	WF1220B	WF1220W	WF5215	WF5215W	WF52153B	WF52153W	WF56301B	WF56301W	1.25mm <sup>2</sup> , 2mm <sup>2</sup> , 2.5mm <sup>2</sup> , 3.5mm <sup>2</sup>	
	WF1220BK	WF1220W	WF1220B	WF1220W	WF5220	WF5220W	WF52201 Compact Type	-	-	-	2mm <sup>2</sup> , 3.5mm <sup>2</sup>	
2P	⊕	15A 125V	-	-	-	-	-	-	-	-	-	
	⊖	15A 250V	-	-	-	-	-	-	-	-	-	
⊕⊖	20A 250V	WF1220BK ※1	WF1220WK ※1	WF1220B	WF1220W	WF5220	WF5220W	-	-	-	2mm <sup>2</sup> , 3.5mm <sup>2</sup>	
	30A 250V	WF1230BK ※1	WF1230WK ※1	WF1230B	WF1230W	WF5220	WF5220W	-	-	-	3.5mm <sup>2</sup> , 5.5mm <sup>2</sup>	
⊕⊖	15A 250V	WF1315BK	WF1315WK	WF1315B	WF1315W	WF5315	WF5315W	-	-	-	1.25mm <sup>2</sup> , 2mm <sup>2</sup>	
	20A 250V	WF1320BK ※1	WF1320WK ※1	WF1320B	WF1320W	WF5320	WF5320W	-	-	-	2mm <sup>2</sup> , 3.5mm <sup>2</sup>	
3P	⊕	20A 250V	WF1320BK ※1	WF1320WK ※1	WF1320B	WF1320W	WF5330	WF5330W	-	-	3.5mm <sup>2</sup> , 5.5mm <sup>2</sup>	
	⊖	30A 250V	WF1330BK	WF1330WK	WF1330B	WF1330W	WF5330	WF5330W	-	-	3.5mm <sup>2</sup> , 5.5mm <sup>2</sup>	
Grounding 2P	⊕	15A 125V	-	-	-	-	WF7002	WF7002W	-	-	1.25mm <sup>2</sup> , 2mm <sup>2</sup>	
	⊖	15A 250V	-	WF3012WK (Cream)	-	-	WF7011	WF7011W	-	-	1.25mm <sup>2</sup> , 2mm <sup>2</sup>	
Grounding 3P (Previously 4P)	⊕	30A 250V	WF3630B	WF3630W	WF3630B	WF3630W	WF5630	WF5630W	-	-	3.5mm <sup>2</sup> , 5.5mm <sup>2</sup>	
	⊖	30A 250V	-	-	WF3630B	WF3630W	WF5630	WF5630W	WF56301B Horizontal Type	WF56301W Horizontal Type	3.5mm <sup>2</sup> , 5.5mm <sup>2</sup>	
Grounding 3P (Previously 4P)	⊕	15A 250V	WF1415BK	WF1415WK	WF1415B	WF1415W	WF5415	WF5415W	-	-	1.25mm <sup>2</sup> , 2mm <sup>2</sup>	
	⊖	20A 250V	WF1420BK ※1	WF1420WK ※1	WF1420B	WF1420W	WF5420	WF5420W	-	-	2mm <sup>2</sup> , 3.5mm <sup>2</sup>	
Grounding 3P (Previously 4P)	⊕	30A 250V	WF1430BK	WF1430WK	WF1430B	WF1430W	WF5430	WF5430W	-	-	3.5mm <sup>2</sup> , 5.5mm <sup>2</sup>	
	⊖	30A 250V	-	-	-	-	-	-	-	-	3.5mm <sup>2</sup> , 5.5mm <sup>2</sup>	

Note: Electrical wire indicated in parentheses ( ) cannot be used for surface mounting receptacles.

Dimensions (Unit: mm)

Flush Mounting Receptacles

WF1220BK-WK, WF1230BK-WK, WF1320BK-WK, WF1420BK-WK, WF1415BK-WK, WF1315BK-WK, WF1220BK-WK, WF3012EK

\*For appropriate plates, please refer to pages 39 & 45

Model No.	Dimension A	Dimension B	Dimension C	Dimension D
2P WF1220BK-WK	38.8	60	34.5	24.1
WF1230BK-WK	42	64.8	40.5	35.3
WF1315BK-WK	37.7	59.5	34.5	21
WF1320BK-WK	37.6	60	34.5	24.1
WF3012EK	38	-	34.5	19.5
Grounding 2P (Previously 2P) WF1415BK-WK	40.4	59	34.5	21
WF1420BK-WK	40.8	59	34.5	24.1

Surface Mounting Receptacles

WF1220BK-WK, WF1230BK-WK, WF1320BK-WK, WF1420BK-WK, WF1415BK-WK, WF1315BK-WK, WF1220BK-WK, WF3012EK

\*For appropriate plates, please refer to pages 39 & 45

Model No.	Dimension A	Dimension B	Dimension C	Dimension D
3P WF1320BK-WK	72.8	80	57	35.3
Grounding 3P (Previously 4P) WF1430BK-WK	68	70	57	35.3
Grounding 3P (Previously 4P) WF3630B-W	72.8	-	-	-

Surface Mounting Receptacles

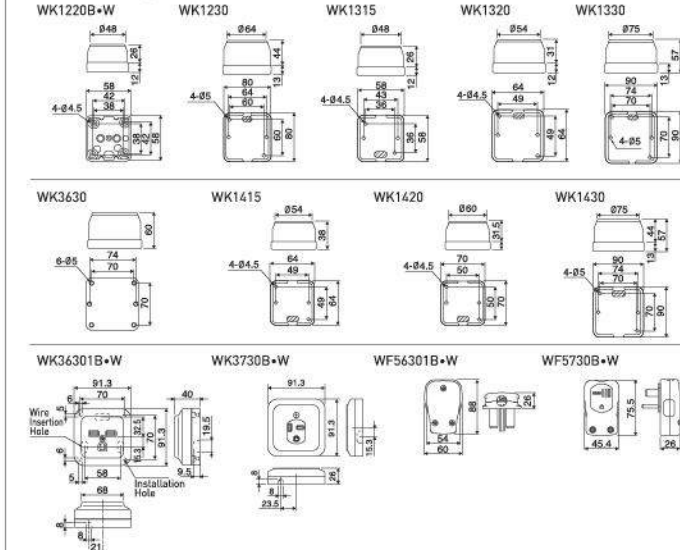

Plugs

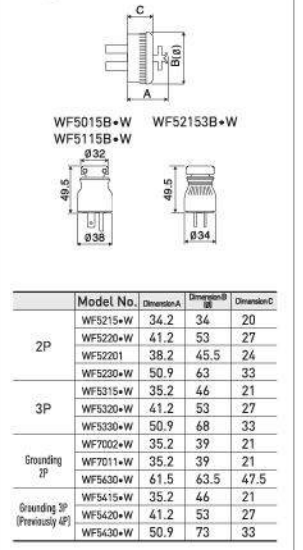

All products have entirely the same specifications as those sold in Japan.

Locking Weather Proof Rubber Cord Connectors, Plugs, Bodies, Locking Plugs, and Locking Cord Connectors

Applicable Wire Types: Rubber Cabtire Cable (Type 2 or less), Round Rubber Cabtire Cord, Vinyl Cabtire Cable, and Round Vinyl Cabtire Cord

Form	Rating	Weather Proof Rubber Cord Connector Plugs and Cord Connector Bodies (JIS Rain-Proof Type)				Applicable Wire Outer Diameter	Rubber Plug (Non-Weather Proof Type)	Applicable Electrical Wire	Cord Connectors (Body)		Cord Connectors (Complete Sets)		Applicable Electrical Wire
		Plug (WF7420K)	Body (WA3429K)	Set (WA3420K)	Plugs				Black	Black			
2P	15A 125V	WF7215K	WA3219K	WA3215K	9.6~12	WF4007 WF4215	1.25mm <sup>2</sup> , 2mm <sup>2</sup>	WA1219	WA1215 (Body WA1219 Plug WF5215)	1.25mm <sup>2</sup> , 2mm <sup>2</sup>			
	15A 250V	-	-	-	-	WF4212	1.25mm <sup>2</sup> , 2mm <sup>2</sup>	-	-	-			
	20A 250V	WF7220	WA3229	WA3220	10.5~13.5	WF4220	2mm <sup>2</sup> , 3.5mm <sup>2</sup>	WA1229	WA1220 (Body WA1229 Plug WF5220)	2mm <sup>2</sup> , 3.5mm <sup>2</sup>			
	30A 250V	WF7230	WA3239	WA3230	12~15	WF4230	3.5mm <sup>2</sup> , 5.5mm <sup>2</sup>	-	-	-			
3P	15A 250V	WF7315	WA3319	WA3315	10.5~13	WF4315	1.25mm <sup>2</sup> , 2mm <sup>2</sup>	WA1319	WA1315 (Body WA1319 Plug WF5315)	1.25mm <sup>2</sup> , 2mm <sup>2</sup>			
	20A 250V	WF7320	WA3329	WA3320	11~14.5	WF4320	2mm <sup>2</sup> , 3.5mm <sup>2</sup>	WA1329	WA1320 (Body WA1329 Plug WF5320)	2mm <sup>2</sup> , 3.5mm <sup>2</sup>			
	30A 250V	WF7330	WA3339	WA3330	13~16	WF4330	3.5mm <sup>2</sup> , 5.5mm <sup>2</sup>	-	-	-			
Grounding 2P	15A 125V	WF75159	WA3519K	WA35159	10.5~13	WF7005K WF7004	0.75mm <sup>2</sup> ~ 2mm <sup>2</sup> , 1.25mm <sup>2</sup> , 2mm <sup>2</sup>	WA1519	WA1515 (Body WA1519 Plug WF7002)	1.25mm <sup>2</sup> , 2mm <sup>2</sup>			
	15A 250V	WF7615	WA3619	WA3615	10.5~13	WF7013	1.25mm <sup>2</sup> , 2mm <sup>2</sup>	WA1619	WA1615 (Body WA1619 Plug WF7011)	1.25mm <sup>2</sup> , 2mm <sup>2</sup>			
	30A 250V	WF7630	WA3639	WA3630	13~16	WF4630	-	-	-	-			
		-	-	-	-	-	-	-	-	-	-		
Grounding 3P (Previously 4P)	15A 250V	WF7415	WA3419	WA3415	11.5~14	WF4415	1.25mm <sup>2</sup> , 2mm <sup>2</sup>	WA1419	WA1415 (Body WA1419 Plug WF5415)	1.25mm <sup>2</sup> , 2mm <sup>2</sup>			
	20A 250V	WF7420K	WA3429K	WA3420K	12~16	WF4420	2mm <sup>2</sup> , 3.5mm <sup>2</sup>	WA1429	WA1420 (Body WA1429 Plug WF5420)	2mm <sup>2</sup> , 3.5mm <sup>2</sup>			
	30A 250V	WF7430	WA3439	WA3430	14~17.5	WF4430	3.5mm <sup>2</sup> , 5.5mm <sup>2</sup>	-	-	-			

Note: • For outdoor wiring exposed to rain, use either rubber cabtire cable or vinyl cabtire cable.  
• For indoor locations exposed to moisture or high humidity, use rubber cabtire cable.  
• If you use stranded wire on screw terminal, please don't solder up the copper wires at the terminal.  
There is a possibility that heating will occur since long time use may bring about oxidizing on surface of solder and make the contact between terminal and solder defective.

Model No.	Dimension A (mm)	Dimension B (mm)	Dimension C (mm)	
<b>• Cord Connectors</b>				
2P	WA1215	87.5	34	39
2P	WA1220	107.5	53	52
3P	WA1315	91.5	45	42
3P	WA1320	107.5	53	52
Grounding 2P	WA1515	91.5	39	42
	WA1615	91.5	39	42
Grounding 3P (Previously 4P)	WA1415	91.5	46	42
	WA1420	107.5	53	52
<b>• Weather Proof Rubber Plugs</b>				
2P	WF7215K	60	39	12
2P	WF7220	90	54	13.5
2P	WF7230	120	69.5	15
2P	WF7315	78	48	12.5
3P	WF7320	90	54	14.5
3P	WF7330	120	69.5	16
Grounding 2P	WF75159	60	39	13
	WF7615	78	48	12.5
Grounding 3P (Previously 4P)	WF7630	102	73	16
	WF7415	78	48	14
Grounding 3P (Previously 4P)	WF7420K	91	61	16
	WF7430	120	69.5	17.5
<b>• Weather Proof Rubber Cord Connectors</b>				
2P	WA3215K	123		
2P	WA3229	197		
2P	WA3230	264		
2P	WA3315	170.5		
3P	WA3320	197		
3P	WA3330	264		
Grounding 2P	WA35159	126		
	WA3615	169.5		
Grounding 3P (Previously 4P)	WA3630	229		
	WA3415	170.5		
Grounding 3P (Previously 4P)	WA3420K	193		
	WA3430	264		
<b>• Weather Proof Rubber Cord Connector Bodies</b>				
2P	WA3219K	74	46	12
2P	WA3229	120	67	13.5
2P	WA3239	160	85	15
2P	WA3319	105	58	13
3P	WA3329	120	67	14.5
3P	WA3339	160	85	16
Grounding 2P	WA3519K	75	46	13
	WA3619	105	58	13
Grounding 3P (Previously 4P)	WA3639	143	83	16
	WA3419	105	58	14
Grounding 3P (Previously 4P)	WA3429K	120	73	16
	WA3439	160	85	17.5
<b>• Rubber Plugs</b>				
2P	WF4007	53	34	10.5
2P	WF4215	50	32	13
2P	WF4212	54	39	12
2P	WF4220	68	50	13.5
2P	WF4230	90	68.2	15
3P	WF4315	60	45.2	13
	WF4320	68	50.2	14.5
Grounding 2P	WF4330	90	68.2	16
	WF7005K	50	32	13
Grounding 3P (Previously 4P)	WF7004	50	39	10
	WF7013	50	39	10
Grounding 3P (Previously 4P)	WF4630	100	69.5	16
	WF4415	60	45.2	14
Grounding 3P (Previously 4P)	WF4420	70	52.2	16
	WF4430	90	68.2	17.5

All products have entirely the same specifications as those sold in Japan.

Switches

Contact Structure

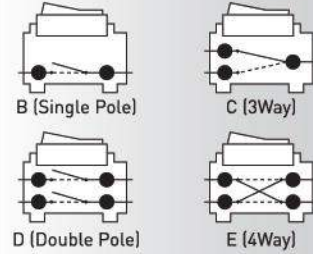

Switch, Single Pole

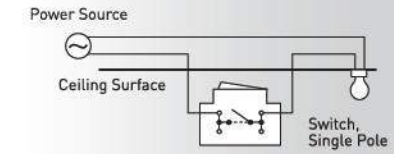

Example of Switches  
WEV5001SW WNV5001-7W WEV5511  
WNG5051W-751 WEV5001-75W WEV5511-7  
WEG5151-75W WMT501-VN

Switch, 3Way

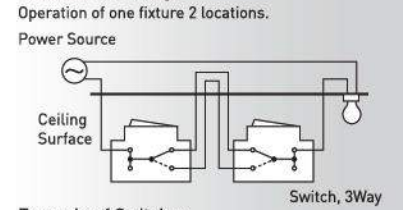

Example of Switches  
WEV5001SW WNV5002-7W WEV5002-75W  
WNG5052W-751 WEG5152-51KSW WEG515275W  
WEV5512 WEV5512-7 WMT502-VN

Switch, Double Pole

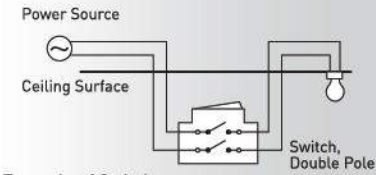

Example of Switches  
WEG5003KSW WEVH5003  
WNG5003W-7

Switch, 4Way

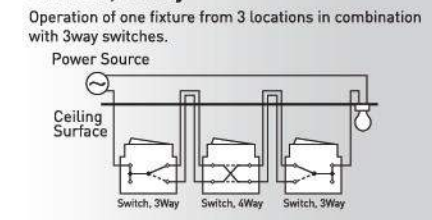

Example of Switches  
WEG5004KSW WEVH5004  
WNG5004W-7 WMT594-VN

Glow Switch (3Way)

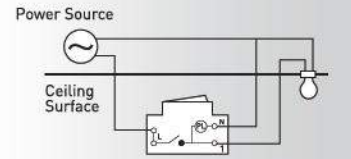

Example of Switches  
WEG5341

Wiring Instructions [Combination with Pilot Lamp]

Glow Switch 3 wire

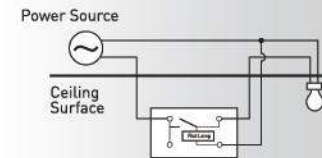

Pilot Lamp Location Indicator

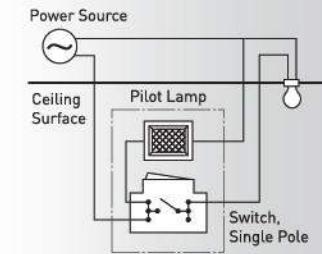

Switch On/Pilot Lamp On

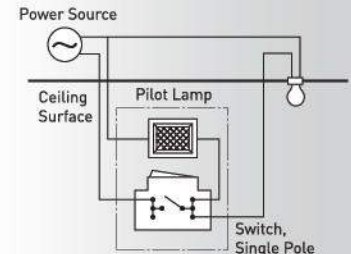

Switch Off/Pilot Lamp On

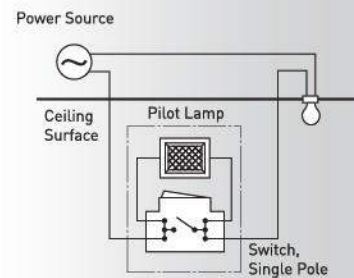

Door Chime

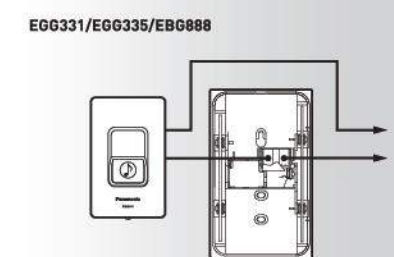

Dimmer Unit

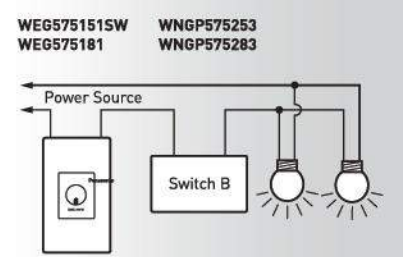

Easy Installation (WEV2488SW/WEV2488H/WEV24886SW/WEV24886H)

**1 2Way Connection**  
**Toolless**  
 Wire Connection by Using Captip  
 • Use tool when connecting wires 0.65mm  
 • Cut the excess wires with nippers after connection

**2 Easy to Remove the Cap**  
 • After connecting the core wires, press the cap down until you hear a click.

**3 Cable Fixing System**  
 • Fix the cable steadily during installation.  
 • Prevent overpeeling of the Sheath of the cable to avoid failures/malfunctions

**4 No Need to Untwist the Wires**  
 • No need to untwist the wires on setting to the slots.  
 • Minimum untwisting makes uniform installation quality & transmission performance.

**Using Wiring Tool**  
 Wiring Tool D.Impact Tool  
 • Excess wires can be cut with the blade edge of the tool

Pin/Pair Assignment

T568A		T568B		Pair No.	
Pin No.	Color	Pin No.	Color	Pair No.	Color
1	W-BL	5	5	1	W-BL
2	BL	4	4	2	W-O
3	W-O	3	1	3	O
4	O	6	2	4	W-G
5	W-G	1	3		G
6	G	2	6		W-BR
7	W-BR	7	7		BR
8	BR	8	8		

Straight Connection with T568A

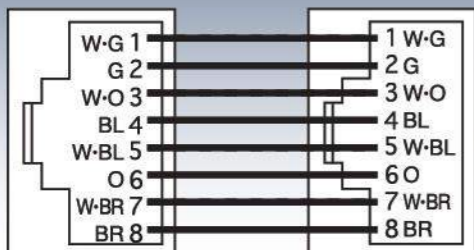

Cross Connection for 10BASE-T/100BASE-TX

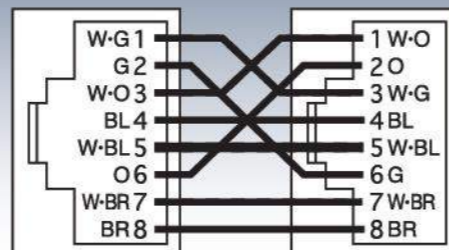

MINERVA

Unit: mm

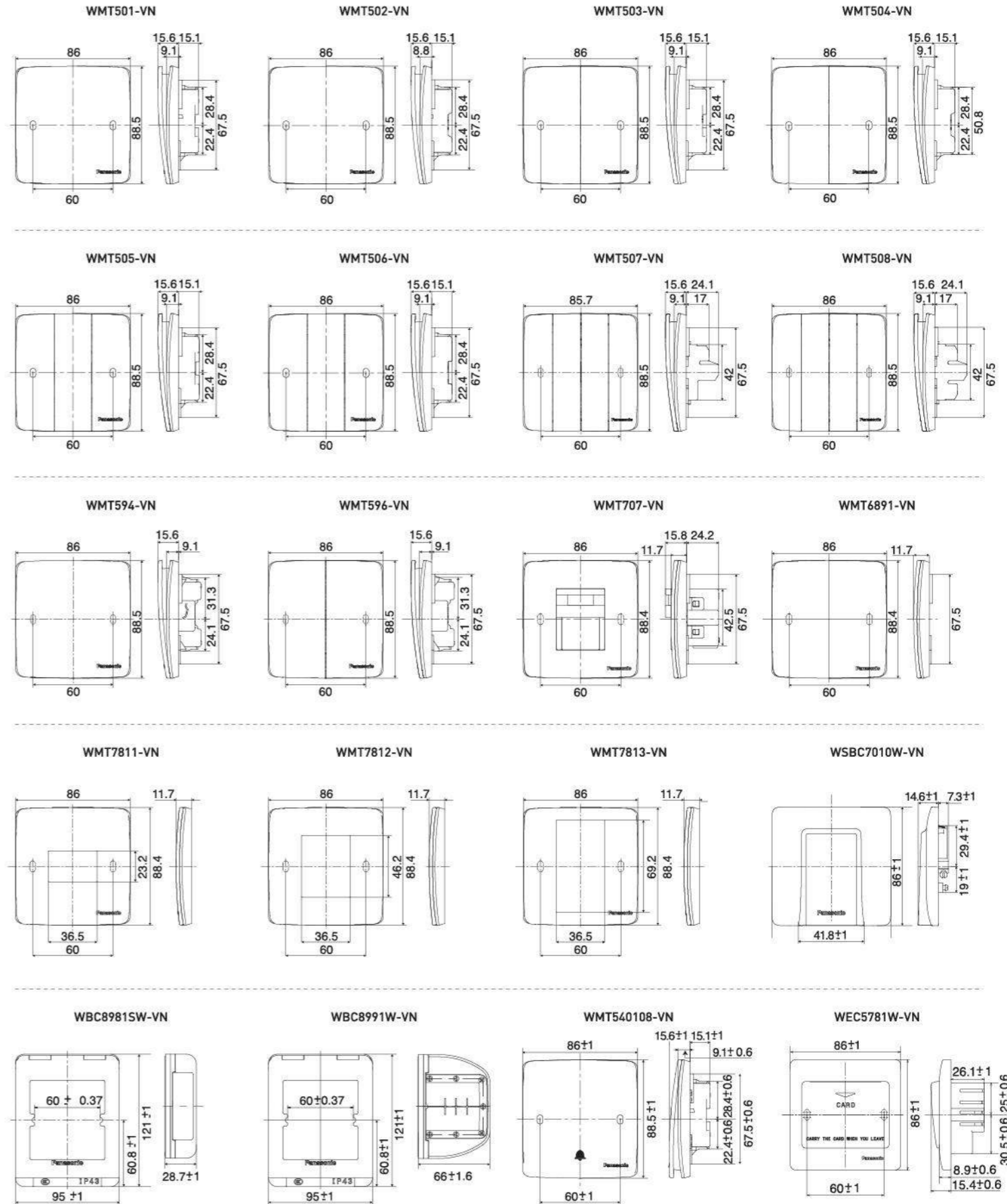

# Halumie

Unit: mm

## Plates

	<p>Plastic Plate 1-Gang 1-Device</p>	<p>Plastic Plate 1-Gang 2-Device</p>	<p>Plastic Plate 1-Gang 3-Device</p>	<p>Plastic Plate 1-Gang Cover</p>
	WEVH68010	WEVH68020	WEVH68030	WEVH68910
<p>Plastic Plate 1-Gang Center 2-Device</p>	<p>Plastic Plate 2-Gang 4-Device</p>	<p>Plastic Plate 2-Gang 6-Device</p>	<p>Plastic Plate 1-Gang for HB Breaker</p>	
WEVH680290	WEVH68040	WEVH68060	WEVH8061	

WEVH5511K

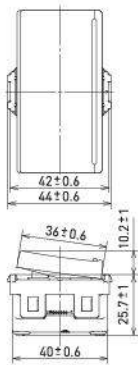

WEVH5521K

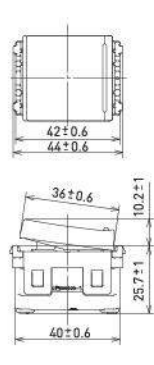

WEVH5531K

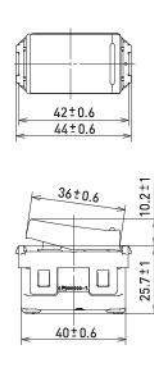

WEVH5512

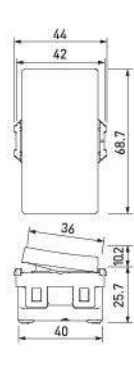

WEVH5522

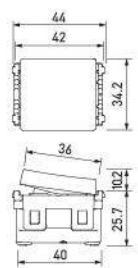

WEVH5532

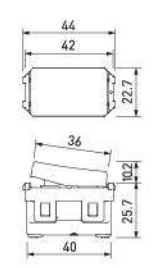

WEVH5003K

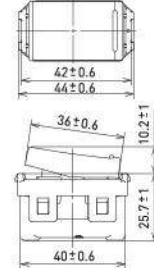

WEVH5004

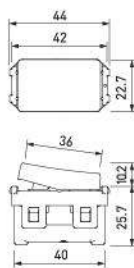

WEVH5151-51

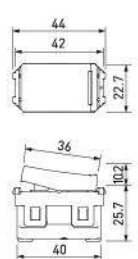

WEVH5152-51

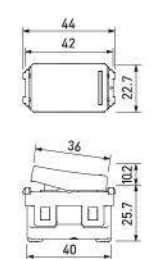

WEVH5511-7K

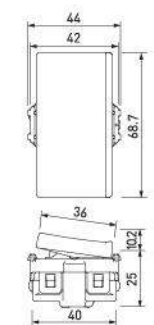

WEVH5521-7K

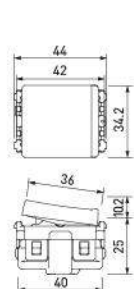

WEVH5531-7K

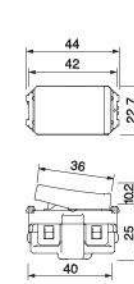

WEVH5512-7



WEVH5522-7

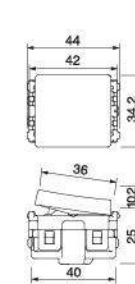

WEVH5532-7

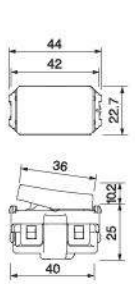

WEVH5151-7

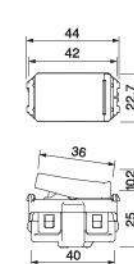

WEVH5152-7

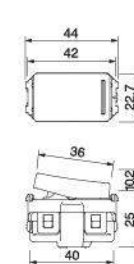

WEVH5033-7

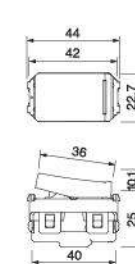

WEVH5542-7

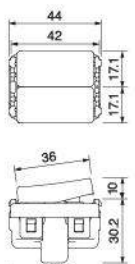

WEV1081SW  
WEV1091SW  
WEV1081-7SW

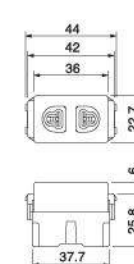

WEV1181SW  
WEV1181-7SW

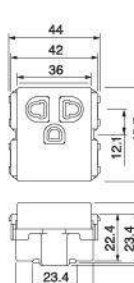

WEV1582SW  
WEV1582-7SW

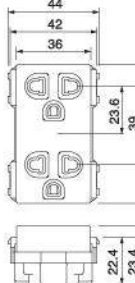

WEV2486SW  
WEV2488SW



WEV2364SW

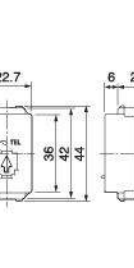

WEV2501SW

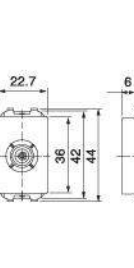

WEG3023SW

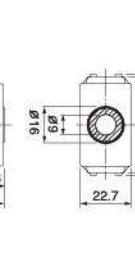

WEG3020SW

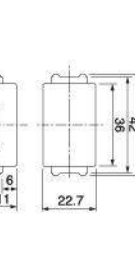

WEVH5401-011

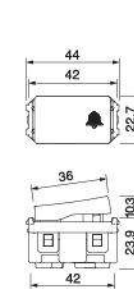

WEG575151SW

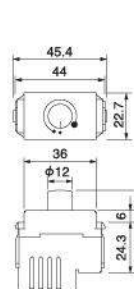



WNV5001-7W

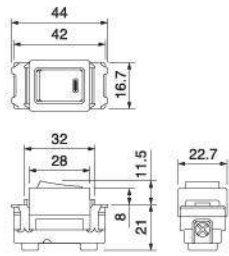

WNV5002-7W

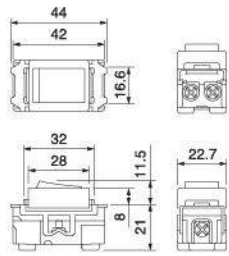

WNG5003-7W

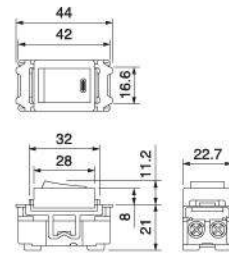

WNG5004-7W

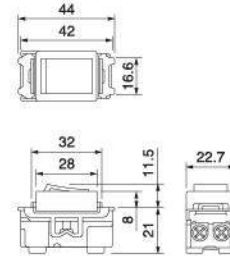

WN3020W

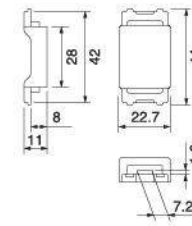

WN3023W

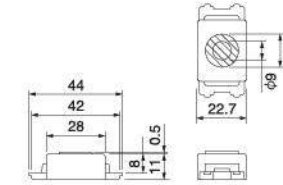

WNV1081-7W  
WNV1091-7W

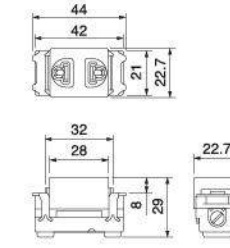

WNG15923-7W

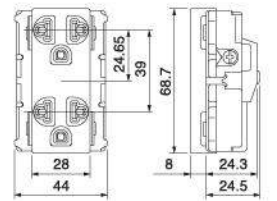

WNG5051W-751

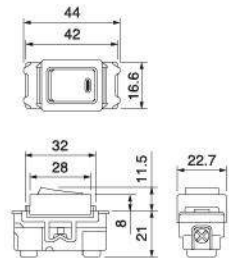

WNG5052W-751

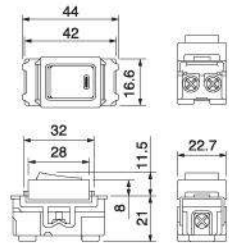

WN5241W-801

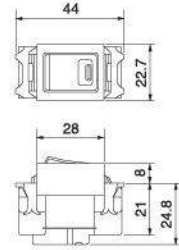

WNG5021W-7

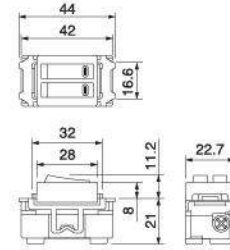

WN1090-7K-W

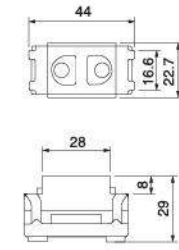

WN1001-7K-W

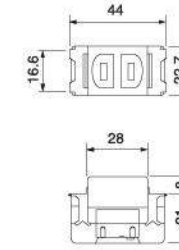

WN1101-7W

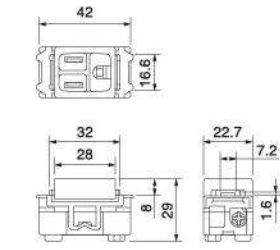

WNTG15649W

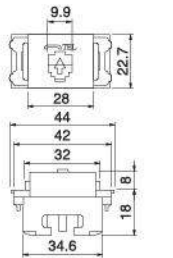

WNG5061-701W

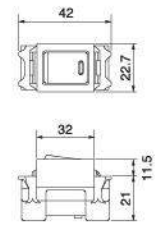

WNG5401W-7K

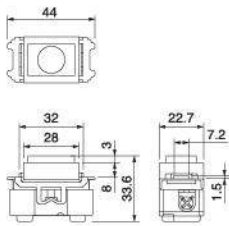

WBG5408699W

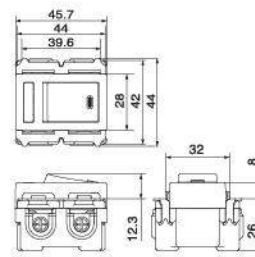

WBG5414699W-SP  
WBG5414699W

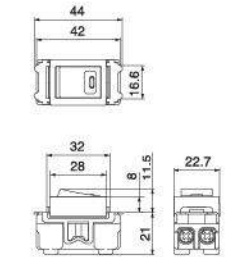

NRV3160W

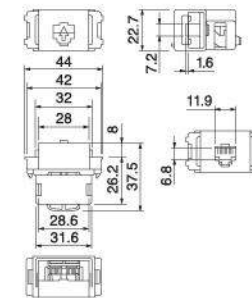

WZV1201W

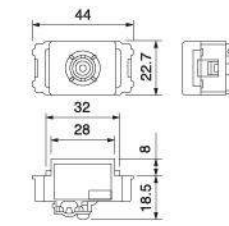

WSG3001

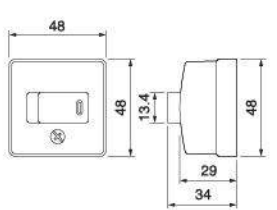

WNG5343W-761

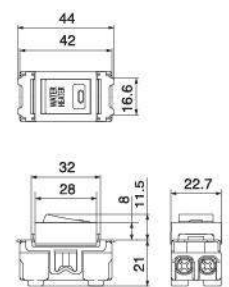

WNGP575283W

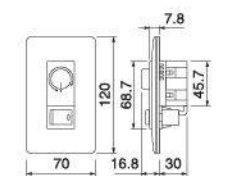

WNGP575152W

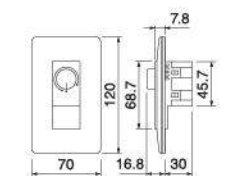

WNH5611-801

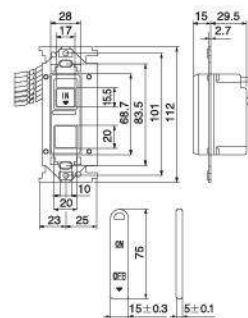

WK1091-250

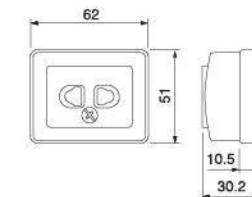

WKG1092-250

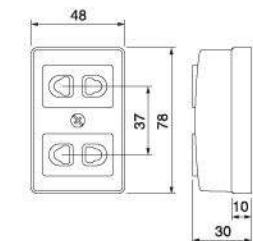



High safety that complies with Thai industrial standard (TIS) and civilized design in Japan  
**HIGH SAFETY AND DURABILITY**



**Durability:**

- Extension cord equipped with highly reliable and safe Panasonic receptacles
- Compatible for both home and office use

**Features:**

- Maximum capacity 16A, 3,500W
- Line-up available from 3, 5 and 6 modules
- Glow switched receptacles for precise ON/OFF function are also available
- Safety shutter with rigid body
- Build in breaker for overload protection

16A, 250V~

**WCHG28334**  
Extension Cord (3 Sockets)



**WCHG28352**  
Extension Cord (5 Sockets)



**WCHG2836**  
Extension Cord (6 Sockets)



Extension Cord With Safty Shutters & Breaker,  
 3 Sockets With Main Switch & 3-Meter Cord  
**PERFECT FIT FOR YOUR INTERIOR**



**Durability:**

- Suitable to every type of residence space with Simple and Casual design
- Compact and Round shape

**Features:**

- Maximum capacity 10A, 2,500W
- Equipped with safety shutter
- Build in breaker for overload protection

10A, 250V~

**WCHG24332W-G**  
Extension Cord (3 Sockets)

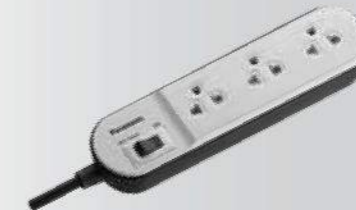

**WCHG243322W-VN**  
Extension Cord (3 Sockets) with 2-Port USB Charger



**Features**



**Features**

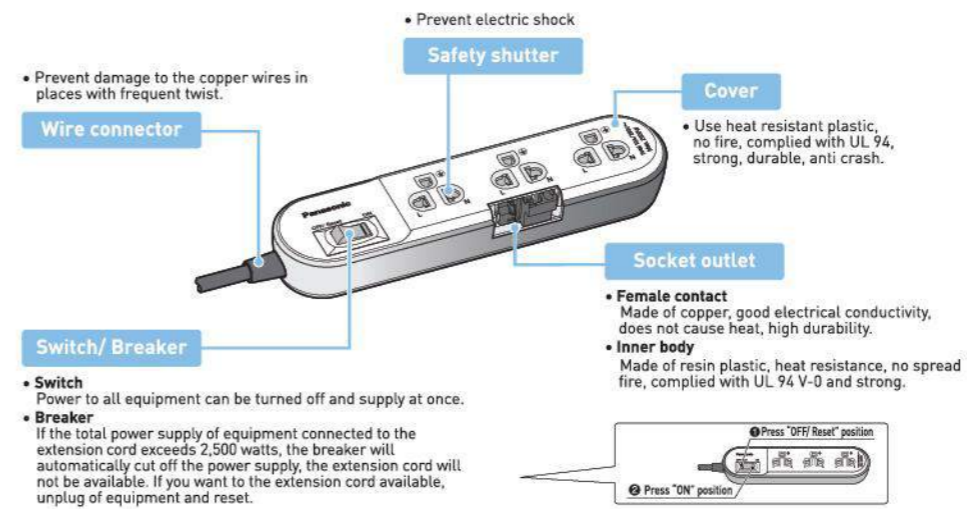

**Installation**



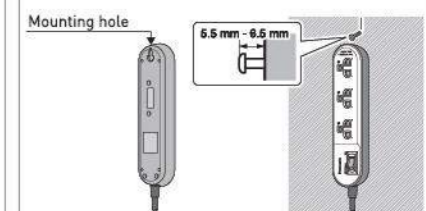

Can be fixed to a wall using the mounting hole  
 Hang using wooden screws  
 Diameter 4.5mm, length 16mm above

Remark: Wooden screws (Not include in the extension cord, available on the market)



# FLOOR OUTLET

Panasonic has a wide range of series depending on the application and building

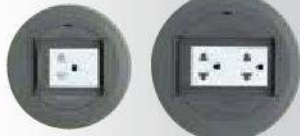
Product Type	Feature	Specification	Recommended Location
<b>Pop-up type</b> 	<ul style="list-style-type: none"> <li>• Users are familiar with this type</li> <li>• Durability to withstand heavy use</li> <li>• Easy to plug</li> </ul>	<ul style="list-style-type: none"> <li>• Plate 7.6mm</li> <li>• 3 Modules</li> <li>• IP44</li> </ul>	<ul style="list-style-type: none"> <li>• Temporary use such as vacuum cleaner</li> <li>• Heavy-duty use</li> </ul>
<b>Shallow type</b> 	<ul style="list-style-type: none"> <li>• Hard to stumble with thin type</li> <li>• Auto-close door prevent dust and water from entering</li> <li>• Small Square design</li> <li>• 46mm box depth (Shallow)</li> </ul>	<ul style="list-style-type: none"> <li>• Plate 3.5mm</li> <li>• 3 Modules</li> <li>• IP44</li> </ul>	<ul style="list-style-type: none"> <li>• Dusty place</li> <li>• Places where design is important, such as shop or cafe</li> </ul>
<b>Double Duplex type</b> 	<ul style="list-style-type: none"> <li>• Large module capacity (6 modules)</li> <li>• Luxury finish</li> </ul>	<ul style="list-style-type: none"> <li>• Plate 6.6mm</li> <li>• 6 Modules</li> <li>• IP44</li> </ul>	<ul style="list-style-type: none"> <li>• Where large module capacity is required such as office</li> </ul>
<b>Plug stored type</b> 	<ul style="list-style-type: none"> <li>• The plug can be stored inside, making it difficult to trip</li> </ul>	<ul style="list-style-type: none"> <li>• Plate 4.0mm</li> <li>• 3 Modules</li> <li>• IP44</li> </ul>	<ul style="list-style-type: none"> <li>• Places that always use Power, TEL or LAN such as office</li> </ul>
<b>Resin type</b> 	<ul style="list-style-type: none"> <li>• 2 types: Single or Duplex</li> <li>• Small and low cost</li> </ul>	<ul style="list-style-type: none"> <li>• Plate 3.7mm~4.1mm</li> <li>• 2 or 3 Modules</li> <li>• IP24</li> </ul>	<ul style="list-style-type: none"> <li>• Two types available, ideal for residential use</li> </ul>

## Panasonic Quality

We have passed severe tests based on our own standards. The following is an example:

### 1. Cover open-close durability

Open the cover by hand and let the cover close down test 10,000 times

### 2. Load performance test

Rolling 1,000N load on the Floor outlet 10,000 times



**NEW**



**New blank types are available, and modules can be freely selected**

**DU5900VT**

Blank with Outlet Box and Box Protector

## Shallow Type

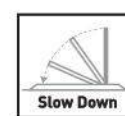

Comfortable with automatic lid mechanism

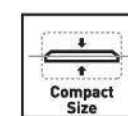

Flat and Fit the Floor surface



Dust and Water proof at safety level IP44

Adapted Module	3 modules (Full-color wide)
IP performance	IP44
Height of upper plate (mm)	3.5
Material	Aluminum Diecast
Dimension (mm)	130 x 130
Depth of BOX (mm)	69

## DUFS1200LTH-1

Floor Outlet Shadow Aluminum diecast without inside Wiring Devices for Full-Color WIDE series IP44



## Double Duplex Type

**6 modules mountable**  
Multiple combination of Power and Data

COVER



WIRING DEVICES



Adapted Module	3 modules (Full-color wide)
IP performance	IP44
Height of upper plate (mm)	6.6
Material	Aluminum Diecast
Dimension (mm)	130 x 130
Depth of BOX (mm)	58

## DUMF3200LT-1

Without Inside Wiring Devices for Full-Color WIDE series



## Pop-up Type

Temporary use such as vacuum cleaner

Adapted Module	3 modules (Full-color wide)
IP performance	IP44
Height of upper plate (mm)	7.6
Material	Aluminum Diecast
Dimension (mm)	130 x 130
Depth of BOX (mm)	69



## Plug stored Type

Places that always use Power, TEL or LAN such as office

Adapted Module	3 modules (Full-color wide)
IP performance	IP44
Height of upper plate (mm)	4.0
Material	Aluminum Diecast
Dimension (mm)	130 x 130
Depth of BOX (mm)	69



### Pop-up Floor Outlet IP-44

**NEW**

**DU5900VT**  
Blank with Outlet Box and Box Protector



**DU5990LT9-1**  
Grounding Duplex Parallel with Outlet Box and Box Protector 16A 250V~



**DU5993LT9-1**  
Grounding Duplex Parallel with Outlet Box and Box Protector 16A 250V~



**DU5983LT9-1**  
Grounding Duplex Universal with Safety Shutter with Outlet Box and Box Protector 16A 250V~



**DU59833LT9-1**  
Grounding Universal with Safety Shutter 16A 250V~ and Telephone Modular Jack 6P4C with Outlet Box and Box Protector



**DU59835LT9-1**  
Grounding Universal with Safety Shutter 16A 250V~ and CAT5E Modular Jack with Outlet Box and Box Protector



**DU6933LT9-1**  
Duplex Telephone Modular Jack 6P4C with Outlet Box and Box Protector



**DU6935LT9-1**  
Telephone Modular Jack 6P4C and CAT5E Modular Jack with Outlet Box and Box Protector



**DU6955LT9-1**  
Duplex CAT5E Modular Jack with Outlet Box and Box Protector



### Floor Outlet [Aluminum Diecast] IP-44

**DUF1200LTK-1**  
Blank with Outlet Box and Box Protector for FULL-COLOR WIDE SERIES Wiring Devices



**DUF1260LTK-1**  
Grounding Duplex Universal with Safety Shutter with Outlet Box and Box Protector 16A 250V~



**DUF1270LTK-1**  
Grounding Duplex Universal with Outlet Box and Box Protector 16A 250V~



**DUF2214LTK-1**  
Telephone Modular Jack 6P4C and CAT5E Modular Jack with Outlet Box and Box Protector



**DUF2229LTK-1**  
Duplex Telephone Modular Jack 6P4C with Outlet Box and Box Protector



**DUF2259LTK-1**  
Duplex CAT5E Modular Jack with Outlet Box and Box Protector



**DUF3221LTK-1**  
Grounding Universal with Safety Shutter 16A 250V~ and Telephone Modular Jack 6P4C with Outlet Box and Box Protector



**DUF3234LTK-1**  
Grounding Universal with Safety Shutter 16A 250V~ And CAT5E Modular Jack with box Protector and Outlet Box



**DUF5200LT-1**  
Blank with Outlet Box and Box Protector for BS Type Wiring Devices



## Resin Type

Two types available, ideal for residential use

Adapted Module	Single : 2 modules (Full-color wide) Duplex : 3 modules (Full-color wide)
IP performance	IP24
Height of upper plate (mm)	Single: 3.7 Duplex: 4.1
Material	Plastic
Dimension (mm)	Single: φ114 Duplex: φ134
Depth of BOX (mm)	64

Single



Duplex



### Floor Outlet Single IP-24

**DU8102HTC-1**  
Grounding Universal with Safety Shutter with Cover Unit 16A 250-



**DU5102HTC-1**  
Grounding Single Parallel with Cover Unit 16A 250-



**DU5199HTC-1**  
Floor Outlet Blank for Single Device with Cover Unit



**DU61233HTC-1**  
Duplex Telephone Modular Jack 6P4C Cover Unit



### Floor Outlet Duplex IP-24

**DU61223HTC-1**  
Telephone Modular Jack 6P4C and TV Terminal Cover Unit



**DU7199HTC-1**  
Floor Outlet Blank for Double Device with Cover Unit



**DU51031HTK-1**  
Grounding Duplex Parallel with Outlex Box and Box Protector 16A 250-



**DU81931HTK-1**  
Grounding Duplex Universal with Outlex Box and Box Protector 16A 250-



**DU81831HTK-1**  
Grounding Duplex Universal with Safety Shutter with Outlex Box and Box Protector 16A 250-



**DU81835HTK-1**  
Grounding Universal with Safety Shutter and CAT5E Modular Jack with Outlex Box and Box Protector 16A 250-



**DU612331HTK-1**  
Duplex Telephone Modular Jack 6P4C with Outlex Box and Box Protector 16A 250-



**DU612351HTK-1**  
Telephone Modular Jack 6P4C and CAT5E Modular Jack with Outlex Box and Box Protector



**DU61355HTK-1**  
Duplex CAT5E Modular Jack with Outlex Box and Box Protector



**DU61466HTK-1**  
Duplex CAT6 Modular Jack with Outlex Box and Box Protector



**DU8199HTK-1**  
Floor Outlex, Blank for Triple Device with Cover Unit



## How to mount

### Floor Outlet

After putting the concrete on, make the hole to install the product.

- (1) Hammer the center part of where the box is installed and make the hole for installation.
- (2) After chipping the concrete away, loosen cover unit screws and take the box protector off.

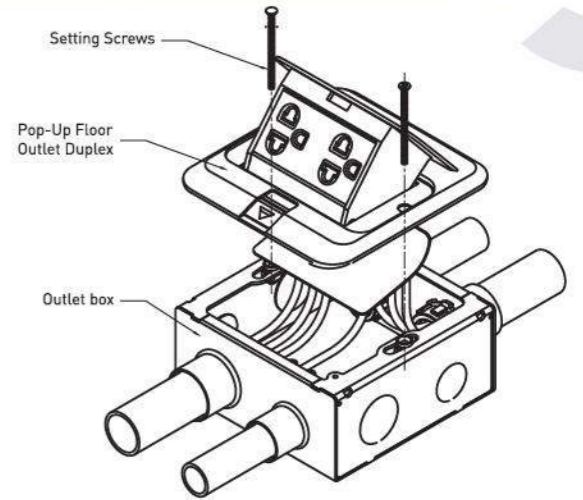
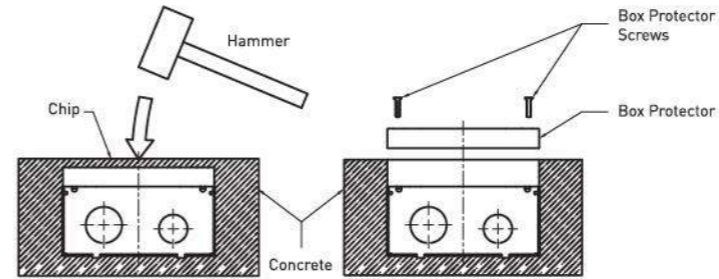

### Floor Outlet Double

The upper surface of the protection cover must be the finished surface of the concrete.

Smash the protection cover and remove the screws.

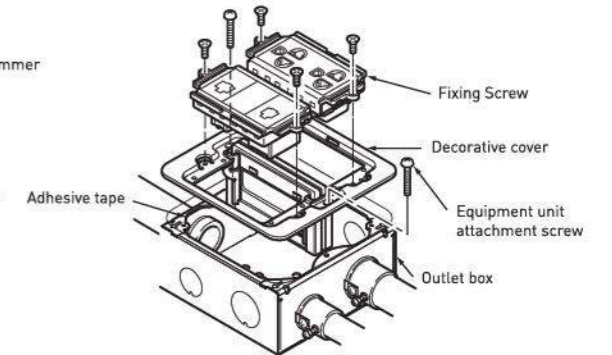
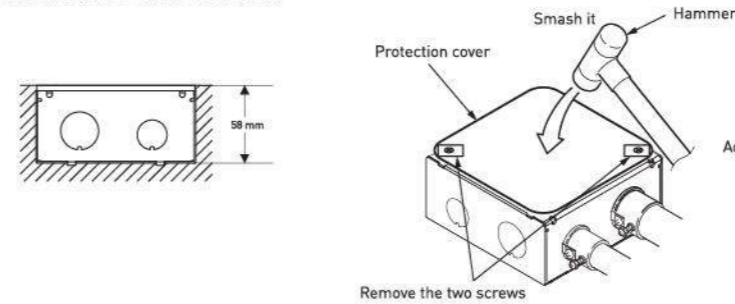

## Drawings

### Floor Outlet Shallow Type

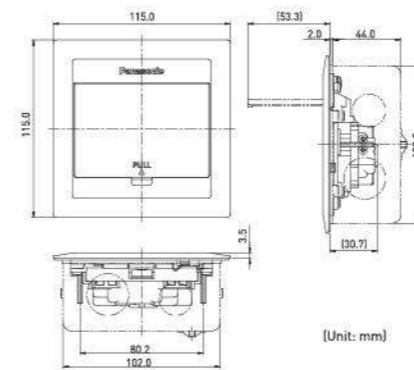

### Pop-up Floor Outlet

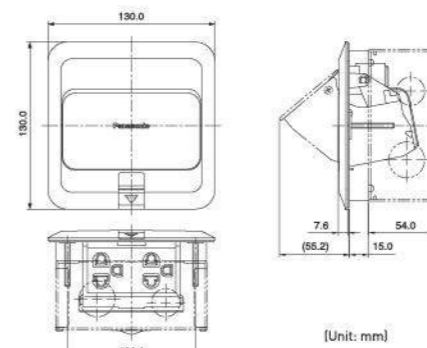

### Floor Outlet (Aluminum Diecast)

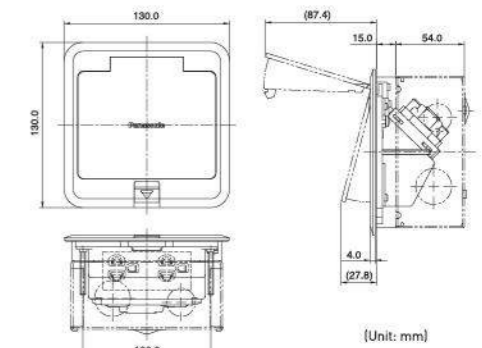

### Floor Outlet Double

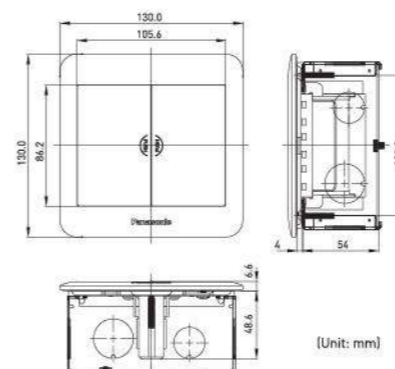

### Floor Outlet Single

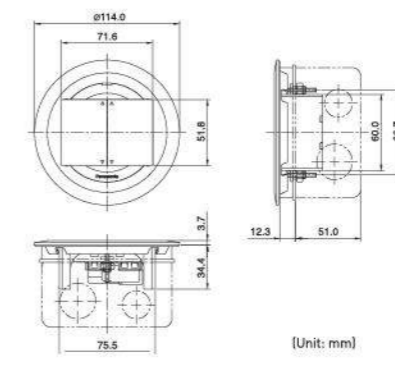

### Floor Outlet

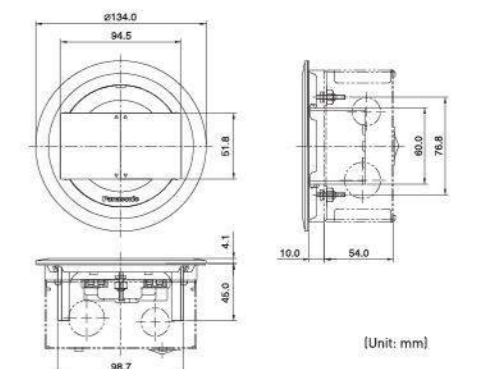

New innovation with  
New energy-saving lighting control  
**PASSIVE INFRARED SENSOR**



FULL-COLOR  
**WIDE**  
SERIES

**Saves Energy Preventing Forgotten On Lights**

**Demonstration**

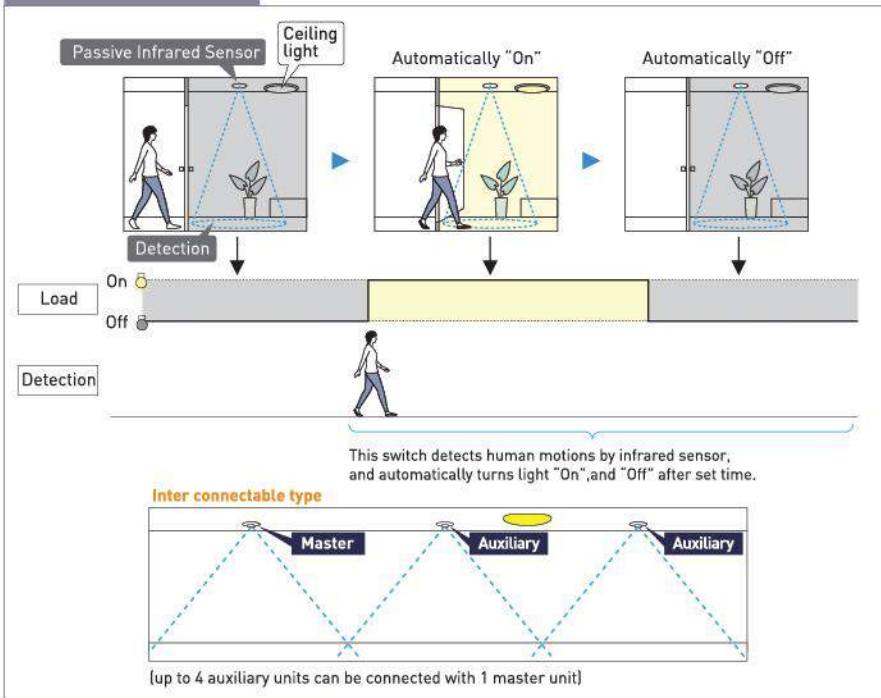

**Features**

- 1) High sensitive detection with sensor
- 2) Long life 100,000 On/Off
- 3) Safety and Easy with Quick Connect Terminal
- 4) Stand by power consumption less than 2W

**Recommended Location**

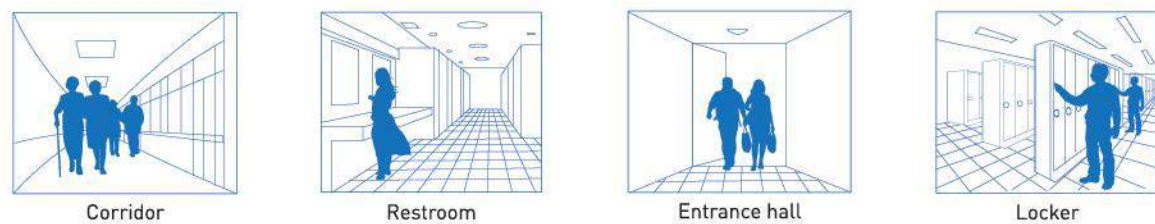

**Wiring Method**

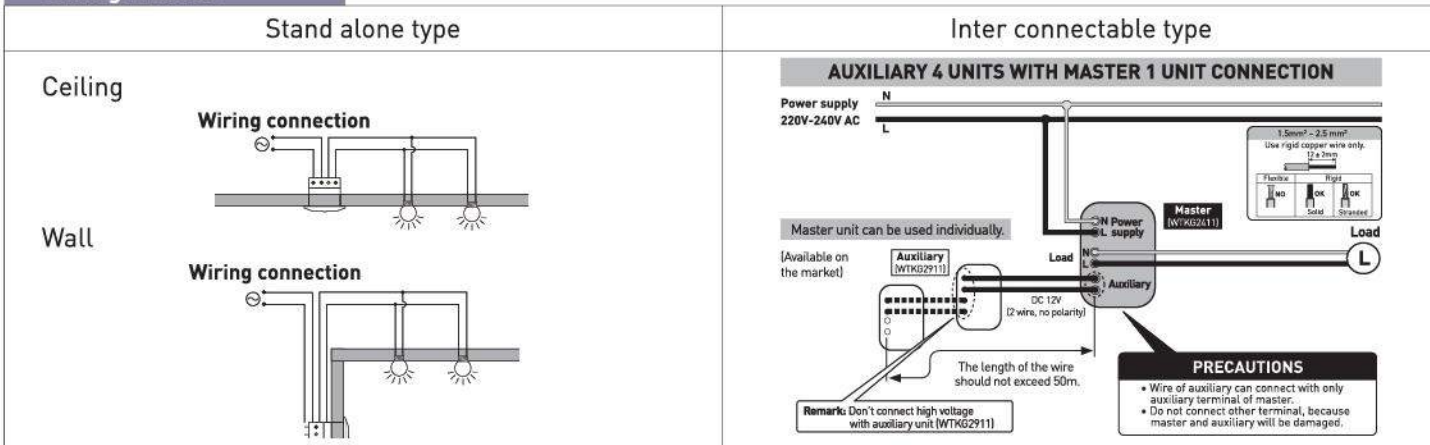

**Stand-alone Type**

**WTKG2311**

Passive Infrared Sensor  
(Ceiling Surface Mount Type)  
3A 220-240V-10 sec - 30 mins. Time Delay  
Day Light Sensor



**WTKG2310**

Passive Infrared Sensor  
(Ceiling Flush Mount Type)  
3A 220-240V-1 min Time Delay



**WEBFP57311W-VN**

WEBFP57311W8, Passive Infrared Sensor with Plate (Wall Flush Mount)



**Specifications**

Model no.	WTKG2311	WTKG2310	WEBFP57311W-VN
Detectable scope	<p>Height for detection 1.7m Height for detection 3.0m Height for detection 3.5m 2.0m Ø3.9m Ø3.6m Ø7.0m Ø4.2m (With hood)</p>	<p>Height for detection 1.7m Height for detection 3.0m Ø3.9m Ø7.0m</p>	<p>Top View Wall About 3.0m 90° About 5.0m Sensor Directions About 5.0m About 3.0m About 30° About 3.0m Side View est. 1.5m</p>
Dimension	<p>17 ± 0.6 33.5 ± 1 120 ± 1.6 Ø120 x 33.5 + 17 (L=50.5mm)</p>	<p>58.8 ± 1.6 12 ± 1.6 85 ± 1.6 Ø85 x 12 + 58.8 (L=70.8mm)</p>	<p>26.5 ± 1 65.8 ± 1 20 ± 0.6</p>
Rating	3A 220-240V~		220-240V~
Rated Power Consumption	Less than 2W		Less than 1W
Load Capacity	Incandescent Lamp 660W Fluorescent Lamp 330W		Incandescent Lamp 2A Fluorescent Lamp 1A
Applicable Standard	IEC60669 - 2 - 1		-
Ambient Temperature	-10°C to +40°C		-10°C to +40°C
Wiring Connection	Quick Connect Terminal		Screw Terminal
Size of Installation Hole (cm)	7.0 (+0.5)	7.2 (+0.5)	-
Applicable Wire	1.5mm <sup>2</sup> - 2.5mm <sup>2</sup> Rigid Copper Wire Only		1.5mm <sup>2</sup> - 2.5mm <sup>2</sup> Rigid Copper Wire Only
Applicable Boxes	Square Box: 2 inch or more Octagon Box: 2 inch or more	1.5 inch or more 1.5 inch or more	1.5 inch or more -
Time-Out Delay	Fixed 1min.	Adjustable 10sec. - 30min.	3min. ± 30sec.
Detectable Movement Speed	0.3m/s ~ 1.0m/s		0.3m/s

### Interconnectable Type

**WTKF24816-VN**  
Passive Infrared Sensor  
(Master Unit)  
8A 220-240V~

**Master**



**WTKG2411**  
Passive Infrared Sensor  
(Master Unit)  
3A 220-240V~

**Master**



**WTKG2911**  
Passive Infrared Sensor  
(Auxiliary Unit)  
DC12V

**Auxiliary**



### Specifications

Model no.	WTKF24816-VN	WTKG2411 / WTKG2911
Detectable scope	<p>Use (attachment) special shading Cover detection range can be narrowed</p> <p>Dark gray area indicates - No hood range Light gray area indicates - Range when there is a hood</p> <p>Use finger softly press on sensor and turn (15° oblique ; 360° turn around)</p>	
Dimension		<p>Ø85 x 12 + 58.8 (L=70.8mm)</p>
Rating	8A 220-240V~	3A 220-240V~
Rated Power Consumption	Less than 1W	Less than 2W
Load Capacity	Incandescent Lamp 1760W Fluorescent Lamp 880W LED Lamp 880W	Incandescent Lamp 660W Fluorescent Lamp 330W
Applicable Standard	-	IEC60669 - 2 - 1
Ambient Temperature	-10°C to +40°C	-10°C to +40°C
Wiring Connection	Quick Connect Terminal	Quick Connect Terminal
Size of Installation Hole (cm)	Ø70 (+0.5)	Ø70 (+0.5)
Applicable Wire	1.5mm <sup>2</sup> - 2.5mm <sup>2</sup> Rigid Copper Wire Only	1.5mm <sup>2</sup> - 2.5mm <sup>2</sup> Rigid Copper Wire Only
Applicable Boxes	Square Box: 2.5 inch or more Octagon Box: 2.5 inch or more	2 inch or more 2 inch or more
Time-Out Delay	Adjustable 10sec. - 30min.	Adjustable 10sec.-30min.
Detectable Movement Speed	0.3m/s ~ 1.0m/s	0.3m/s ~ 1.0m/s

## Provides prompt notification in the event of a fire SLIM SMOKE & VOICE ALARM WITH LONG-LIFE-BATTERY



Rapid indication with a clear "alarm sound" and a "voice" easy to understand.

Approx. 87dB at 1m distance from equipment (at peak value) (measured by our company based on corporate judgment standard)  
For alarm sound "Whiz, whiz", a wide frequency band from 0.3kHz to 4.0kHz is adopted for easy catching even by old people and children.

### Immediately understands what happened.

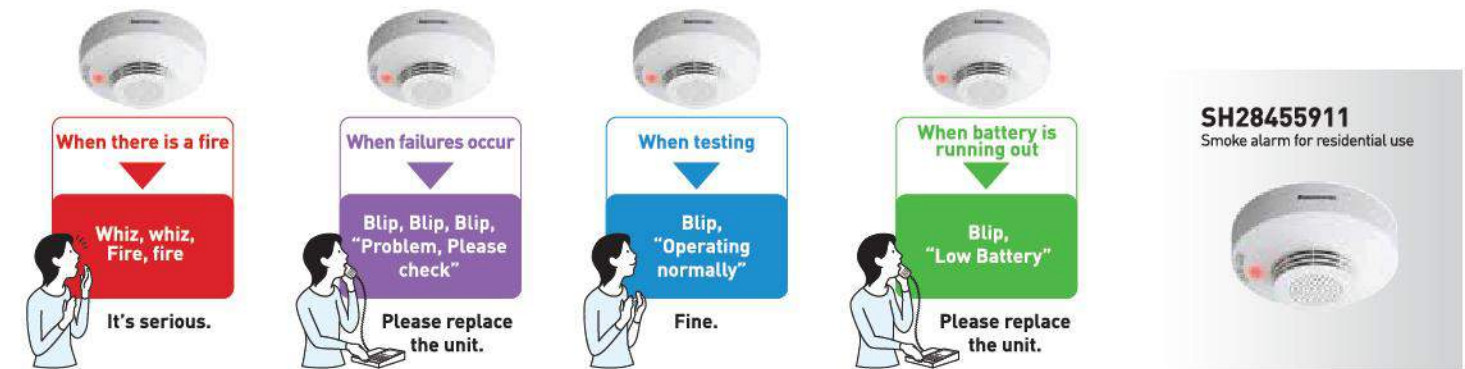

Model No.	SH28455911	
Power Supply	Dedicated Lithium Battery (3V) x 1	
Battery Life	Approximately 10 years [*]	
Detecting Method	Smoke Type (Photoelectric Method)	
Class	Type2	
Alarm Sound/ Voice Alarm	Fire	Whiz, whiz, fire, fire!
	Low Battery	"Blip, Low Battery!" x 3 times "Blip, approx., every 40 seconds after that"
	Trouble	"Blip, blip, blip, Problem, Please check" x 3 times "Blip, blip, blip," approx., every 40 seconds after that"
Alarm Volume	84 dB or more at 1m distance from equipment	
Dimension	Approx. Ø100mm x 44mm (Including attachment base)	
Weight (Including Dedicated Lithium Battery)	Approx. 140g	
Operating Temperature	0 °C to +50 °C	
Installation Location	Ceiling/ Wall Surface	

Mode	Voice Alarm	Indication
Normal		OFF
Alarm	Whiz Whiz Fire Fire	Blink
Silent	-	OFF
Trouble #1	Blip, Blip, Blip, Problem please check	Blink
Trouble [Silent]	-	Blink
Low Battery #2	Blip, Low Battery	Blink every 8 seconds
Low Battery [Silent]	-	Blink every 8 seconds

Available in a wide variety of models to suit a multitude of environmental and weather conditions

## AUTOMATIC TIME SWITCH



## What's an Automatic Time Switch?

An automatic time switch automatically controls the use of electricity according to time. It's a device that lowers both electrical and labour costs.

### Automatically Turns the Power On and Off

The Time Switch combines a clock with a switch to automatically turn power on or off at preset times. It is generally built into a lightboard or distribution panel, and controls electricity on a 24-hour. It makes it possible to replace conventional manual control with automated, reliable ON/OFF time management.

### Simply Set the Time for ON/OFF Control

Time management consists of simply setting the times to turn the power on and off. A wide range of uses are possible across various operations, such as lighting, air conditioning, water supply, and livestock feeding.

### Eliminating Waste of Power Is Also Ecological

Because the power is reliably turned on and off according to a preset time schedule, the amount that was wasted by extended use is saved, and electric bills are effectively lowered.

### Cutting Labour Costs Is Also Efficient

Since the job of turning the power on and off is done automatically instead of manually, you can assign your valuable human resources to more important jobs. Human error is also eliminated, so power management is more reliable.

Example: Managing electricity in the office



From 1:00 PM to 6:00 PM

Lighting and air conditioning are turned on precisely when lunchtime ends. Then the power is automatically turned off when the workday finishes. Again, no power is wasted.

From 0:00 PM to 1:00 PM

Lunchtime. Lighting and air conditioning are turned off while people leave the office for lunch. No power is wasted.

From 8:30 AM to 12:00 AM

Turn the power on at the start of the workday. Lighting and air conditioning are turned on to provide a smooth start to office work.

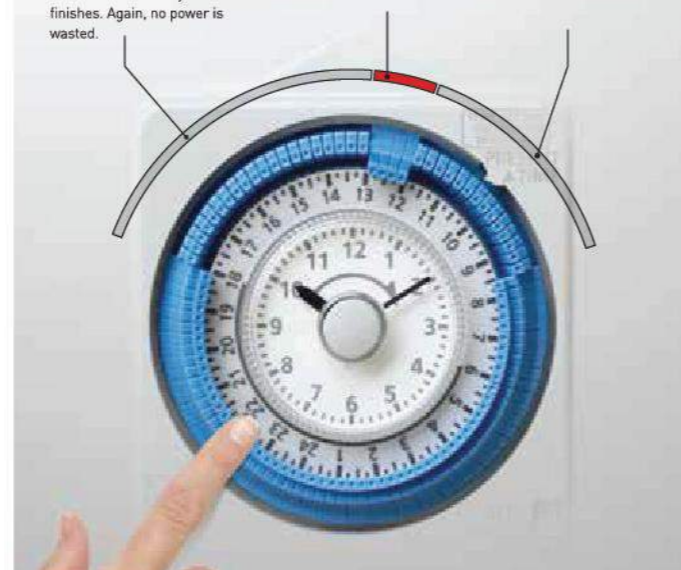

## Uses and Advantage of Panasonic Time Switch

Panasonic, with over 100 years of expertise forged in the Electrical Construction Material field with its Wiring Devices series, has also established a name for itself in the Time Control Devices market during the past 50 years with its Automatic Time Switch.

### Thorough Quality Control

In addition to advanced functions, Panasonic focuses its manufacturing efforts on providing high durability and performance for many years of reliable use, and selects materials with full consideration of the global environment. Certification by third-party institutions and compliance with a wide range of international standards attest to these efforts. This approach is also used with Panasonic's Automatic Time Switches, to allow our customers worldwide to experience a new level of comfort and safety for the control of electric equipment.

### Meeting IEC Standards

Panasonic's product design has been recognised and certified by many international organisations worldwide, such as the IEC (International Electrotechnical Commission), the top reference for electrical and electronic safety standards. Our Automatic Time Switch has successfully passed and complies with the IEC60730-2-7 directives to provide safer and more comfortable use of our line-up to our customers.



### Products Compliant with the RoHS Directive

Panasonic's manufacturing processes are based on management standards for chemical substances by complying with the EU RoHS directive in order to provide all of our customers safer products with less impact on the environment.



### Example of Use

#### Example 1 Offices, Residences and Commercial Facilities

Time Switches can be used to save electricity during the times when lighting and air conditioning are not needed, like at lunchtime and late at night.



#### Example 2 Agriculture and Livestock

Time Switches can be used to automatically supply food and water at appropriate times each day, to increase working efficiency.



Detailed consideration is given to users in the form of functions that are helpful in ordinary usage, and designs that simplify maintenance.

### Easy Operation Check



A power lamp is located on the front panel, so the user can see at a glance whether the unit is operating or not, thus helping to provide safe use.

### Easy Battery Replacement



With conventional time switches, the unit must be removed from its installation location, such as in a distribution panel, to replace the batteries. Panasonic's Time Switch lets you easily replace the batteries from the front panel. This makes maintenance considerably easier.

### Preventing Entry of Ants and Other Small Insects



Time Switches are sometimes subject to the entry of ants and other small insects, which can cause malfunctions. Panasonic Time Switches have an airtight construction that prevents this problem for long, trouble-free use.

**Surface & DIN rail mount type**

TB35N, TB36N, TB38N, TB39N

**Features**

- 24 hours program
- Surface and DIN rail mount
- 300 hours reserve battery [TB38N, 39N]
- \*Battery exchange from the front side
- 96 operations per day
- Minimum setting interval is 15 minutes

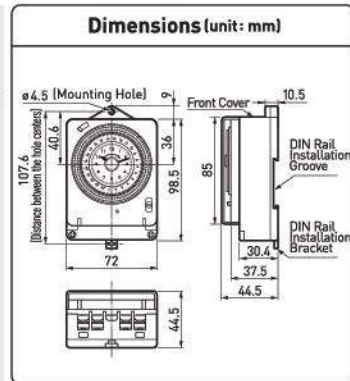

Applicable Installation Type	Indoor Use Daily			
	TB35N series	TB36N series	TB38N series	TB39N series
Series	TB35809NE5 [220-240V AC 50Hz]	TB36809NE5 [220-240V AC 50Hz]	TB38809NE7 [220-240V AC 50Hz]	TB39809NE7 [220-240V AC 50Hz]
Item No.				
Drive Method	AC Motor		Quartz Motor	
Power Failure Backup Time	Same as AC frequency		300 hours	
Time Precision	Same as AC frequency		±15 sec./month [at 25°C]	
Circuit Configuration	Voltage contact output Single Pole, Single Through (1a Contact)	No voltage contact output Single Pole, Double Through (1c Contact)	Voltage contact output Single Pole, Single Through (1a Contact)	No voltage contact output Single Pole, Double Through (1c Contact)
Switch Construction				
Load Capacity	Resistive Load 250V AC 20A Incandescent Lamp Load 250V AC 10A Inductive Load (cos φ ≥ 0.6) 250V AC 12A Motor Load (cos φ ≥ 0.6) 220V AC 1500W Minimum Setting Interval 15 minutes No. of On/Off Operation 96 operations			

**Surface mount type**

TB11N, TB17N

**Features**

- 24 hours program
- On/Off operations are set with separated pins
- With a manual On/Off switch
- 300 hours reserve battery [TB11N]
- \*Battery exchange from the front side

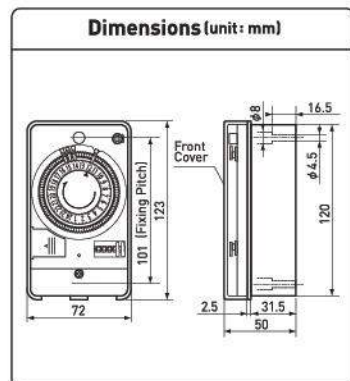

Applicable Installation Type	Indoor Use Daily	
	TB17N series	TB11N series
Series	TB178NE5 [220-240V AC 50Hz]	TB118NE7 [220-240V AC 50Hz]
Item No.		
Drive Method	AC Motor	Quartz Motor
Power Failure Backup Time	Same as AC frequency	300 hours
Time Precision	Same as AC frequency	±15 sec./month [at 25°C]
Circuit Configuration	Voltage contact output Single Pole, Single Through (1a Contact)	
Switch Construction		
Load Capacity	Resistive Load 250V AC 15A Incandescent Lamp Load 250V AC 15A Inductive Load (cos φ ≥ 0.6) 250V AC 12A Motor Load (cos φ ≥ 0.6) 220V AC 1500W Minimum Setting Interval 30 minutes No. of On/Off Operation Standard 6 operations (Max 48 operations)	

TB35N, TB38N [Steel Box Type]

**Features**

- With robust steel box
- 24 hours program
- Surface mount
- 300 hours reserve battery [TB38N]
- \*Battery exchange from the front side
- 96 operations per day
- Minimum setting interval is 15 minutes

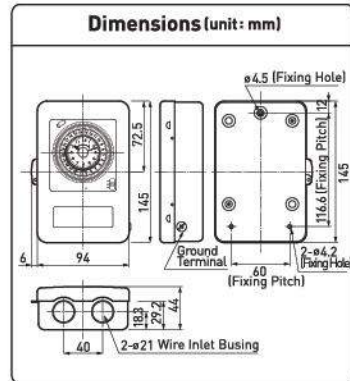

Applicable Installation Type	Indoor Use Daily	
	TB35N series	TB38N series
Series	TB358NE5 [220-240V AC 50Hz]	TB388NE7 [220-240V AC 50Hz]
Item No.		
Drive Method	AC Motor	Quartz Motor
Power Failure Backup Time	Same as AC frequency	300 hours
Time Precision	Same as AC frequency	±15 sec./month [at 25°C]
Circuit Configuration	Voltage contact output Single Pole, Single Through (1a Contact)	
Switch Construction		
Load Capacity	Resistive Load 250V AC 20A Incandescent Lamp Load 250V AC 10A Inductive Load (cos φ ≥ 0.6) 250V AC 12A Motor Load (cos φ ≥ 0.6) 220V AC 1500W Minimum Setting Interval 15 minutes No. of On/Off Operation 96 operations	

TB43N [Plastic Box Type]

**Features**

- 24 hours program
- Surface mount
- Weatherproof type (IP53)
- 300 hours reserve battery [TB43N]
- \*Battery exchange from the front side

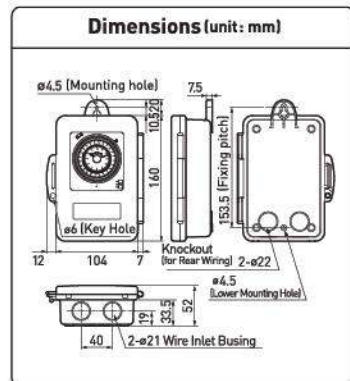

Applicable Installation Type	Outdoor & Indoor Use Daily	
	TB43N Series	
Series	TB438NE7 [220-240V AC 50Hz]	
Item No.		
Drive Method	Quartz Motor	
Power Failure Backup Time	300 hours	
Time Precision	±15 sec./month [at 25°C]	
Circuit Configuration	No voltage contact output Single Pole, Single Through (1a Contact)	
Switch Construction		
Load Capacity	Resistive Load 250V AC 20A Incandescent Lamp Load 250V AC 10A Inductive Load (cos φ ≥ 0.6) 250V AC 12A Motor Load (cos φ ≥ 0.6) 220V AC 1500W Minimum Setting Interval 15 minutes No. of On/Off Operation 96 operations	

**CIRCUIT BREAKERS**



**Breaker**

Miniature Circuit Breaker (MCB)		Residual Current Circuit Breaker (RCCB)		Residual Current Breaker with Over-Current (RCBO)	
Over current and short circuit automatic breaker, full protection for households' basic needs		Earth leakage automatic breaker		Over current, short circuit and earth leakage automatic breaker	
<b>Safety Breaker (HB Type)</b>	<b>Miniature Circuit Breaker (MCB DIN Type)</b>	<b>Earth Leakage Breaker (ELB Small Type)</b>	<b>Earth Leakage Breaker (ELB J Type)</b>	<b>Residual Current Breaker with Over-Current (RCBO DIN Type)</b>	<b>Earth Leakage Breaker (ELB J Type)</b>
Safety circuit breaker, suitable for household appliances	Automatic breaker protect over current and short circuit *DIN rail mountable			*DIN rail mountable	

**Industrial Circuit Breakers**

Molded Case Circuit Breaker (MCCB)			
Over current and short circuit automatic breaker, specialized for industrial needs			
<b>GD Breaker</b> *Made in Japan		<b>Molded Case Circuit Breaker (MCCB) NEW</b>	
<b>BBW</b>	<b>BKW</b>		
		BC-100W	BC-250W



Compact and High Breaking Capacity  
of Circuit Breaker

## MCB-DIN TYPE



Safety Design and Wide Variation of Residual Current  
Circuit Breakers with Overcurrent protection

## RCBO-DIN TYPE



### MCB BD-63R [DIN Type]

Type		BD-63R							
Poles & Elements		1P1E		2P2E		3P3E		4P4E	
Instantaneous		C	D	C	D	C	D	C	D
Type	6A	BBD1061CNV	BBD1061DNV	BBD2062CNV	BBD2062DNV	BBD3063CNV	BBD3063DNV	BBD4064CNV	BBD4064DNV
	10A	BBD1101CNV	BBD1101DNV	BBD2102CNV	BBD2102DNV	BBD3103CNV	BBD3103DNV	BBD4104CNV	BBD4104DNV
	16A	BBD1161CNV	BBD1161DNV	BBD2162CNV	BBD2162DNV	BBD3163CNV	BBD3163DNV	BBD4164CNV	BBD4164DNV
	20A	BBD1201CNV	BBD1201DNV	BBD2202CNV	BBD2202DNV	BBD3203CNV	BBD3203DNV	BBD4204CNV	BBD4204DNV
	25A	BBD1251CNV	BBD1251DNV	BBD2252CNV	BBD2252DNV	BBD3253CNV	BBD3253DNV	BBD4254CNV	BBD4254DNV
	32A	BBD1321CNV	BBD1321DNV	BBD2322CNV	BBD2322DNV	BBD3323CNV	BBD3323DNV	BBD4324CNV	BBD4324DNV
	40A	BBD1401CNV	BBD1401DNV	BBD2402CNV	BBD2402DNV	BBD3403CNV	BBD3403DNV	BBD4404CNV	BBD4404DNV
	50A	BBD1501CNV	BBD1501DNV	BBD2502CNV	BBD2502DNV	BBD3503CNV	BBD3503DNV	BBD4504CNV	BBD4504DNV
	63A	BBD1631CNV	BBD1631DNV	BBD2632CNV	BBD2632DNV	BBD3633CNV	BBD3633DNV	BBD4634CNV	BBD4634DNV
Rated Voltage Interrupting Current	AC240/415V 6kA		AC240V 10kA AC415V 6kA		AC415V 6kA		AC415V 6kA		
Weight	6A-32A 0.1kg 40A-63A 0.13kg		6A-32A 0.2kg 40A-63A 0.26kg		6A-32A 0.3kg 40A-63A 0.39kg		6A-32A 0.4kg 40A-63A 0.52kg		

MCB BD-63R Conform to the IEC 60898-1 standards.

### MCB BD-125 [DIN Type]

Type		BD-125							
Poles & Elements		1P1E		2P2E		3P3E		4P4E	
Instantaneous		C	D	C	D	C	D	C	D
Type	80A	BBD108011C	BBD108011D	BBD208021C	BBD208021D	BBD308031C	BBD308031D	BBD408041C	BBD408041D
	100A	BBD110011C	BBD110011D	BBD210021C	BBD210021D	BBD310031C	BBD310031D	BBD410041C	BBD410041D
	125A	BBD112511C		BBD212521C		BBD312531C		BBD412541C	
Rated Voltage Interrupting Current	AC240V 10kA			AC415V 10kA					
Weight	0.18kg		0.36kg		0.54kg		0.72kg		

MCB BD-125 Conform to the IEC 60947-2 standards.

### RCBO BDE-63R [2P1E] [DIN Type]

Type		BDE-63R					
Poles & Elements		2P1E					
Instantaneous		C	D	C	D	C	D
Type	6A	BBDE20631CNV	BBDE20631DNV	BBDE20641CNV	BBDE20641DNV	BBDE20651CNV	BBDE20651DNV
	10A	BBDE21031CNV	BBDE21031DNV	BBDE21041CNV	BBDE21041DNV	BBDE21051CNV	BBDE21051DNV
	16A	BBDE21631CNV	BBDE21631DNV	BBDE21641CNV	BBDE21641DNV	BBDE21651CNV	BBDE21651DNV
	20A	BBDE22031CNV	BBDE22031DNV	BBDE22041CNV	BBDE22041DNV	BBDE22051CNV	BBDE22051DNV
	25A	BBDE22531CNV	BBDE22531DNV	BBDE22541CNV	BBDE22541DNV	BBDE22551CNV	BBDE22551DNV
	32A	BBDE23231CNV	BBDE23231DNV	BBDE23241CNV	BBDE23241DNV	BBDE23251CNV	BBDE23251DNV
	40A	BBDE24031CNV	BBDE24031DNV	BBDE24041CNV	BBDE24041DNV	BBDE24051CNV	BBDE24051DNV
	50A	BBDE25031CNV	BBDE25031DNV	BBDE25041CNV	BBDE25041DNV	BBDE25051CNV	BBDE25051DNV
	63A	BBDE26331CNV	BBDE26331DNV	BBDE26341CNV	BBDE26341DNV	BBDE26351CNV	BBDE26351DNV
Rated Voltage	AC240V 6kA						
Application Voltage Range	192V-264V						
Rated Residual Operating Current	30mA		100mA		300mA		
Rated Residual Non-operating Current	15mA		50mA		150mA		
Weight	6A-32A 0.2kg 40A-63A 0.23kg						

RCBO BDE-63R Conform to the IEC 61009-1 standards.

### RCBO BDE-63R [4P4E] [DIN Type]

Type		BDE-63R					
Poles & Elements		4P4E					
Instantaneous		C					
Type	6A	BBDE40634CNV	BBDE40644CNV	BBDE40654CNV	BBDE40664CNV	BBDE40674CNV	BBDE40684CNV
	10A	BBDE41034CNV	BBDE41044CNV	BBDE41054CNV	BBDE41064CNV	BBDE41074CNV	BBDE41084CNV
	16A	BBDE41634CNV	BBDE41644CNV	BBDE41654CNV	BBDE41664CNV	BBDE41674CNV	BBDE41684CNV
	20A	BBDE42034CNV	BBDE42044CNV	BBDE42054CNV	BBDE42064CNV	BBDE42074CNV	BBDE42084CNV
	25A	BBDE42534CNV	BBDE42544CNV	BBDE42554CNV	BBDE42564CNV	BBDE42574CNV	BBDE42584CNV
	32A	BBDE43234CNV	BBDE43244CNV	BBDE43254CNV	BBDE43264CNV	BBDE43274CNV	BBDE43284CNV
	40A	BBDE44034CNV	BBDE44044CNV	BBDE44054CNV	BBDE44064CNV	BBDE44074CNV	BBDE44084CNV
	50A	BBDE45034CNV	BBDE45044CNV	BBDE45054CNV	BBDE45064CNV	BBDE45074CNV	BBDE45084CNV
	63A	BBDE46334CNV	BBDE46344CNV	BBDE46354CNV	BBDE46364CNV	BBDE46374CNV	BBDE46384CNV
Rated Voltage	AC415V 6kA						
Application Voltage Range	332V-456V						
Rated Residual Operating Current	30mA		100mA		300mA		
Rated Residual Non-Operating Current	15mA		50mA		150mA		
Weight	6A-32A 0.63kg 40A-63A 0.75kg						

RCBO BDE-63R Conform to the IEC 61009-1 standards.

•MCB (BD-63R)

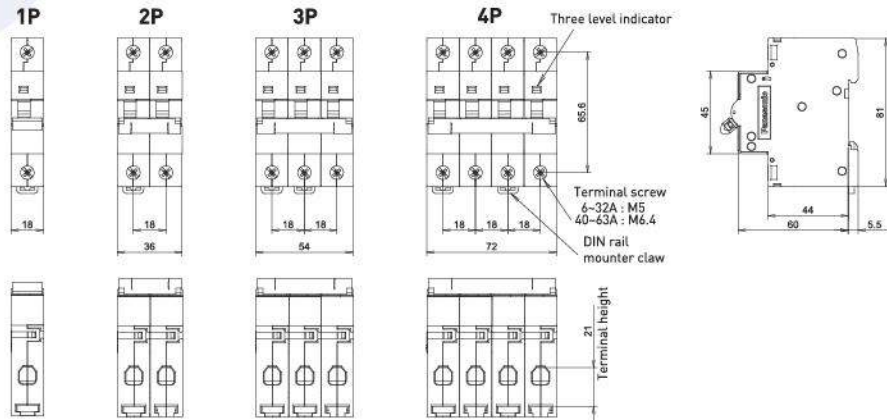

•RCBO (BDE-63R)

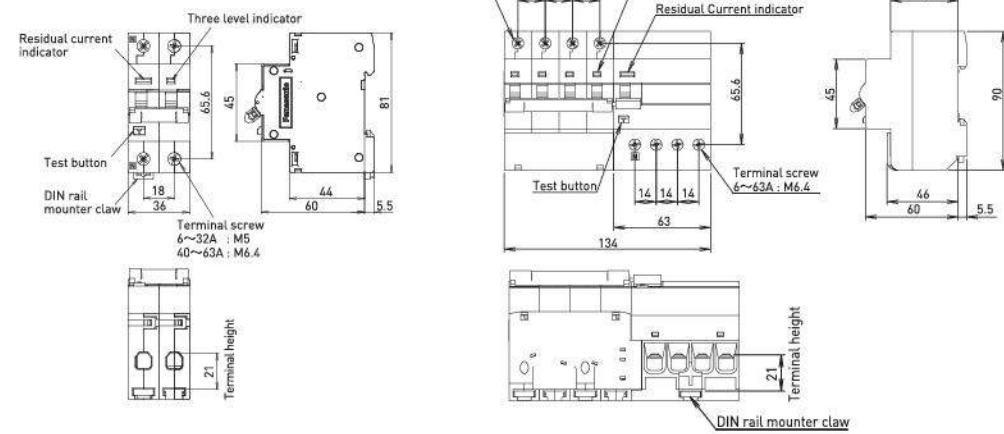

•MCB (BD-125)

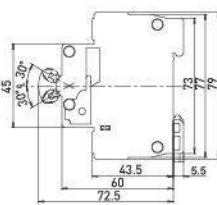
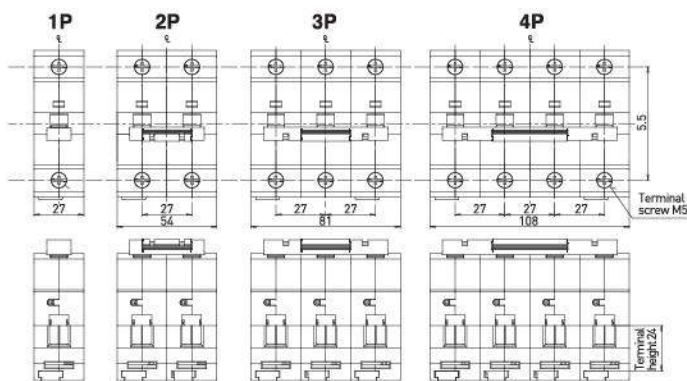

Operating time curve (Standard temperature 30°C)

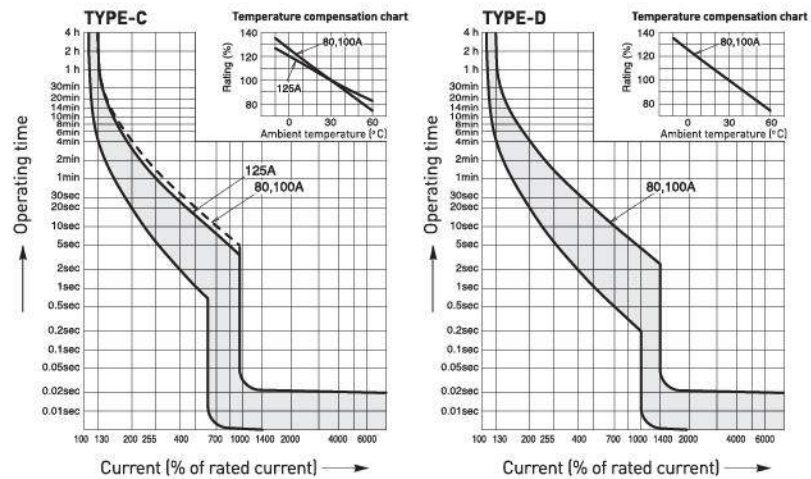

Complete range of products with a compact design  
**SAFETY BREAKER**  
**EARTH LEAKAGE BREAKER**



Earth Leakage Breaker Small Type

Dimension Appearance Mounting Pitch	Unit: mm	
Type	BJS3020NA2	BJS3030NA2
Rated Current	30A	
Number of Poles & Elements	2P0E	
Rated Voltage	AC120-240V	
Residual Operating Current	15mA	30mA
Residual Non-operation Current	7.5mA	15mA
Rated Short-time Current	1.5kA	
Phase and Wiring Configuration	1φ2W	
Operating Time	Within 0.1 sec.	
Handle Type	Long	
Standard Terminal Specifications	Solderless terminals (with strap) φ1.6-φ2.6 5.5 - 8mm <sup>2</sup> Note: When using electrical appliance wire or other stranded wire [1.25 - 3.5mm <sup>2</sup> ] use bar lug terminals WV2500 1.25 - 2mm <sup>2</sup> (WV2501 2.0 - 3.5mm <sup>2</sup> ) Tightening torque: 1.6-2.0N·m 16.3-20.4kgf·cm	
Connecting Method	For direct installation of electrical wiring	
Weight	0.09kg	
Overload Current Tripping Mechanism	None	
Approval Standard	-	

Note: 1. "Rated short-time current" means that although short-circuit protection is not possible, the internal circuitry and conductors can withstand 1.5kA for 0.02 seconds.  
2. Ambient temperature range for usage: -10°C to +50°C.  
3. Disconnect electrical wiring before measuring insulation resistance between wires.

Dimension Appearance Mounting Pitch	Unit: mm								
Type	BJS1512S	BJS1522S	BJS1532S	BJS2012S	BJS2022S	BJS2032S	BJS3012S	BJS3022S	BJS3032S
Rated Current	15A			20A			30A		
Number of Poles & Elements	2P2E								
Rated Voltage	AC100-240V								
Residual Operating Current	10mA	15mA	30mA	10mA	15mA	30mA	10mA	15mA	30mA
Residual Non-operation Current	6mA	7.5mA	15mA	6mA	7.5mA	15mA	6mA	7.5mA	15mA
Rated Interrupting Capacity (Rated Short-time Current)	1.5kA								
Phase and Wiring Configuration	1φ2W, 1φ3W								
Operating Time	Within 0.1 sec.								
Handle Type	Short								
Terminal Specifications	Solderless terminals (with strap) φ1.6-φ2.6 5.5 - 8mm <sup>2</sup> Note: When using electrical appliance wire or other stranded wire [1.25 - 3.5mm <sup>2</sup> ] use bar lug terminals WV2500 1.25 - 2mm <sup>2</sup> (WV2501 2.0 - 3.5mm <sup>2</sup> ) Tightening torque: 1.6-2.0N·m 16.3-20.4kgf·cm								
Connecting Method	For direct installation of electrical wiring								
Weight	0.09kg								
Overload Current Tripping Mechanism	Thermal operation								

Note: 1. Ambient temperature range for usage: -10°C to +50°C.  
2. Disconnect electrical wiring before measuring insulation resistance between wires.

Small Type

Temperature compensation curves

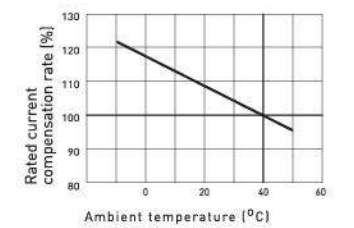

Operating characteristics curves (with O.C.)

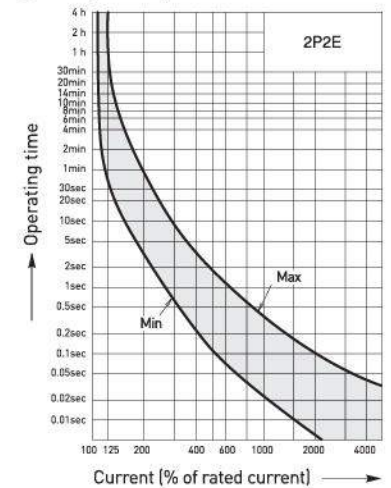

## Earth Leakage Breaker J Type

Dimension Appearance Mounting Pitch							
Number of Poles & Elements	2P0E		2P2E				
Type	BJJ230308	BJJ215228	BJJ215328	BJJ220228	BJJ220328	BJJ230228	BJJ230328
Rated Current	30A	15A		20A		30A	
Rated Voltage	AC120-240V						
Residual Operating Current	30mA	15mA	30mA	15mA	30mA	15mA	30mA
Residual Non-operation Current	15mA	7.5mA	15mA	7.5mA	15mA	7.5mA	15mA
Rated Interrupting Capacity (Rated Short-time Current)	[2.5kA]	1.5kA					
Phase and Wiring Configuration	1φ2W	1φ2W, 1φ3W					
Operating Time	Within 0.1 sec.						
Leakage Indication Method	-	Mechanic button					
Terminal Specifications	Solderless terminals (with strap) φ1.6-φ2.6 5.5 - 8mm <sup>2</sup>		Note: When using electrical appliance wire or other stranded wire (1.25 - 3.5mm <sup>2</sup> ) use bar lug terminals WV2500 1.25 - 2mm <sup>2</sup> (WV2501 2.0 - 3.5mm <sup>2</sup> )				Tightening torque: 1.6-2.0N·m 16.3-20.4kgf·cm
Connecting Method	For direct installation of electrical wiring						
Weight	0.2kg						
Overload Current Tripping Mechanism	Thermal operation						

Note: 1. "Rated short-time current" means that although short-circuit protection is not possible, the internal circuitry and conductors can withstand 1.5kA for 0.02 seconds.  
2. Ambient temperature range for usage: -10°C to +50°C.  
3. Disconnect electrical wiring before measuring insulation resistance between wires.

## J Type

### Temperature compensation curves

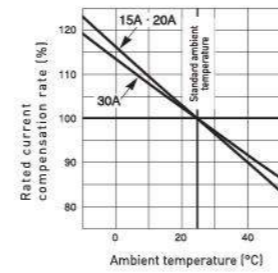

### Operating characteristics curves (with O.C.)

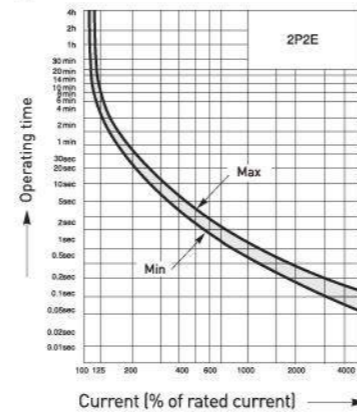

## Safety Breaker HB Type

Dimension Appearance Mounting Pitch		
Number of Poles & Elements	2P1E	
Type	6A	BS11106TV
	10A	BS1110TV
	15A	BS1111TV
	20A	BS1112TV
	30A	BS1113TV
	40A	BS1114TV
Rated Voltage	AC 240V 1.0kA (6A) AC 240V 1.5kA (10-15-20-30-40A)	
Terminal Specifications	Solderless terminals (with strap) φ1.6-φ2.6 5.5 - 8mm <sup>2</sup>	
Weight	0.07kg	
Structure	Tripping Mechanism	Thermal operation
	Arc Quenching Method	Natureal Quenching
Capacity	Interrupting Time	10ms (100%)
	Passage of Short	23 X 10 <sup>3</sup> A <sup>2</sup> sec (100%)

Note: 1. Use 20A for normal branch circuits, and 30A for high capacity dedicated circuits.  
2. Use 15A or less for machine protection, after consideration of its characteristic: inrush current and usual current.  
3. The data in capacity mentioned above are just for your reference, which are PEW's experimental ones.

## HB Type

### Temperature compensation curves

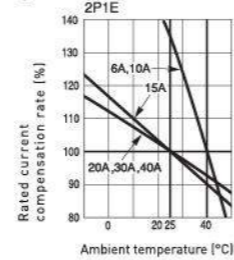

### Operating characteristics curves (with O.C.)

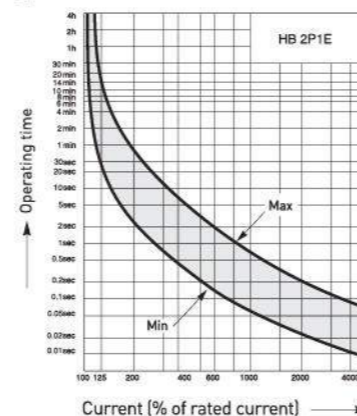

Save space and saving cost

## MOLDED CASE CIRCUIT BREAKER NEW



### No.1

Suitable for isolation with positive contact indication

### No.2

Operation in pollution degree 3 to IEC standard

### No.3

Unlimited performance up to AC440V when reverse-connected

### No.4

Compact size: W75 H130 D68 and high breaking capacity; 25kA 415V BC250

Type	BC-100W		BC-250W		
Reference Standard	IEC 60947-2		IEC 60947-2		
Number of Poles	3P			3P	
Rated Current	63A	100A	150A	200A	250A
Utilisation Category	A type			A type	
	<b>Current specifications</b>				
Max. Rated Operational Voltage	AC 690V			AC 690V	
Rated Insulation Voltage	690V				
Rated Impulse Withstand Voltage	6kV			8kV	
Rated Ultimate S.C. Breaking Capacity @ac 415 (Icu)	10kA			25kA	
Service Short Circuit Breaking Capacity @ac 415v (Ics)	5kA			19kA	
	<b>Protection</b>				
Protection Method	FIXED thermal magnetic			FIXED thermal magnetic	
	<b>Dimension</b>				
Width X High X Depth (mm)	75 x 130 x 68			105 x 165 x 68	
	<b>Special feature</b>				
Line Load Reversibility	Yes			Yes	
Calibration Temperature	40°C			40°C	

• BC-100W

Preparation of conductor

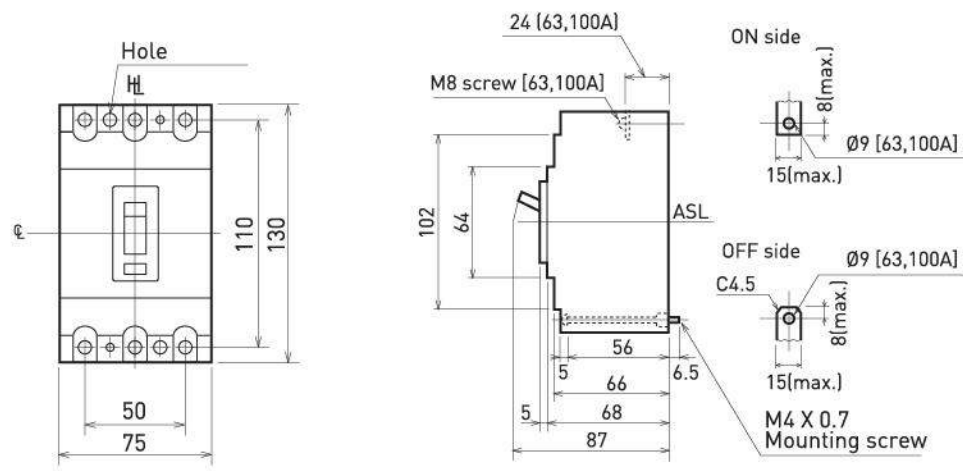

Drilling plan (front view)

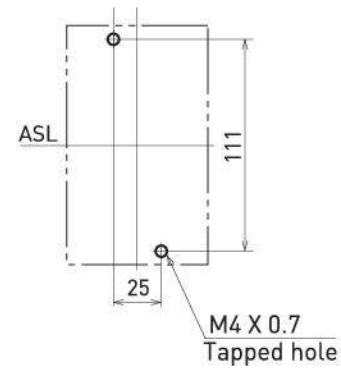

Time/Current characteristic curves

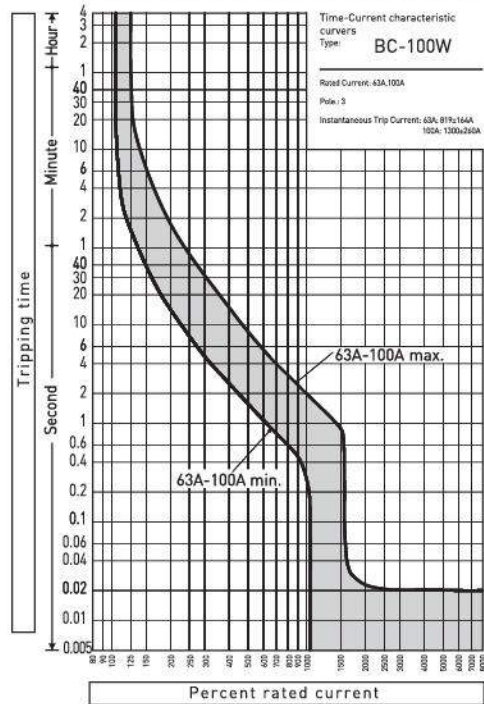

Ambient compensating curves

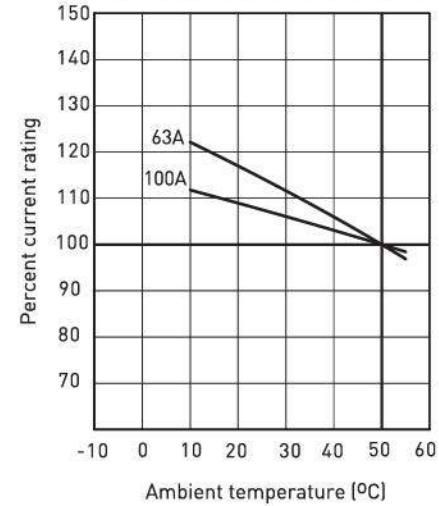

BC-250W

Preparation of conductor

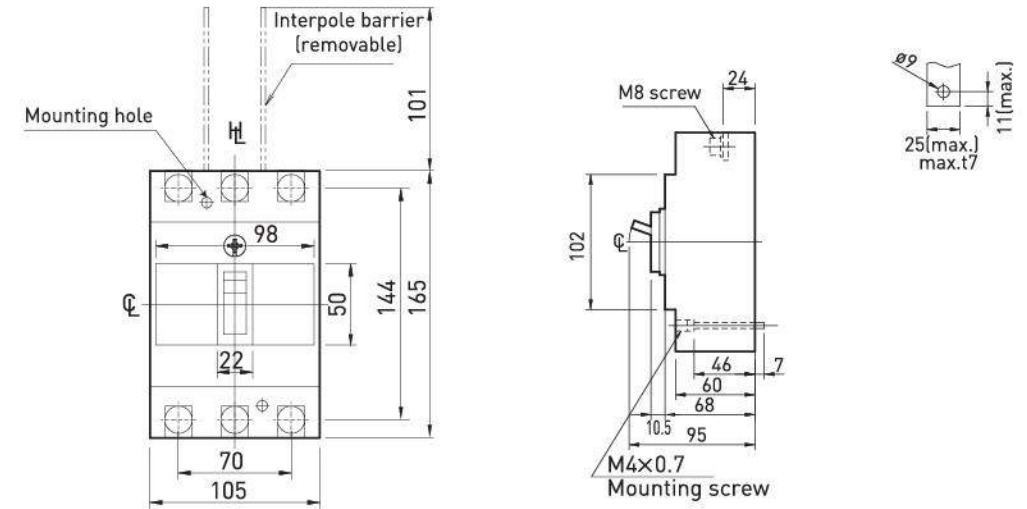

Drilling plan (front view)

Note: For the extension bars, Straight bars or Spread bars can be supplied.

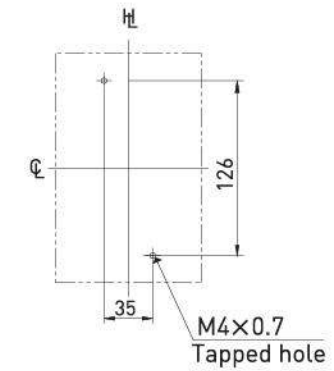

Time/Current characteristic curves

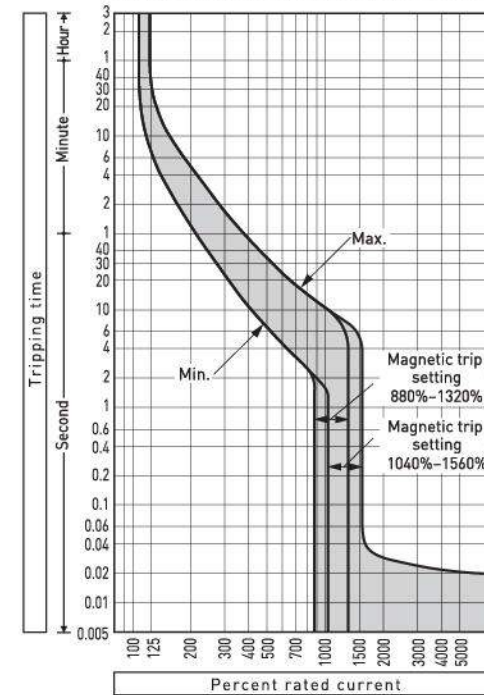

Ambient compensating curves

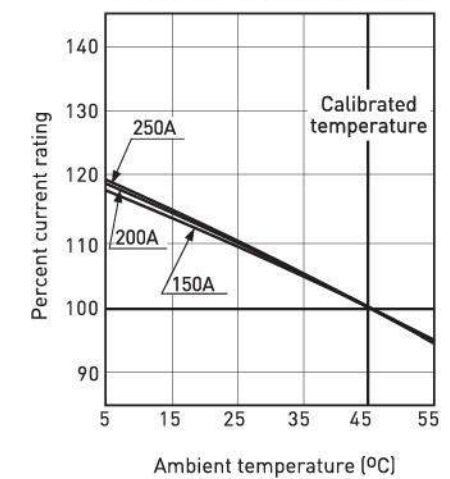



HGC electric interrupting technique is power connection safety design  
Small dimension, high rated interrupting capacity



## GD BREAKER





### •MCCB [BBW Type]

Frame Size		30AF											
Type		BBW-30			BBW-30C								
Appearance					DIN rail mountable 								
Number of Poles		2P		3P		2P		3P					
Cat. No. & Rated Current (Nominal Ambient Temperature 40°C)		3A	BBW23Y	BBW33Y	3A	BBW23CKY	BBW33CKY	5A	BBW25Y	BBW35Y	5A	BBW25CKY	BBW35CKY
		10A	BBW210Y	BBW310Y	10A	BBW210CKY	BBW310CKY	15A	BBW215Y	BBW315Y	15A	BBW215CKY	BBW315CKY
		20A	BBW220Y	BBW320Y	20A	BBW220CKY	BBW320CKY	30A	BBW230Y	BBW330Y	30A	BBW230CKY	BBW330CKY
Rated Insulation Voltage		AC		500V		500V		500V					
JIS Rated Interrupting Capacity (sym)		AC		415V	1.5kA	1.5kA	200V	2.5kA	2.5kA				
		100V		2.5kA	2.5kA								
Dimensions		a		47	70	50		75					
		b		96		96		96					
		c		52		60		60					
		ca		67.6		75.6		75.6					
Weight of Standard Type		0.3kg		0.4kg		0.3kg		0.4kg					

Frame Size		50AF											
Type		BBW-50			BBW-50S								
Appearance					DIN rail mountable 								
Number of Poles		2P		3P		2P		3P					
Cat. No. & Rated Current (Nominal Ambient Temperature 40°C)		20A	BBW2201Y	BBW3201Y	5A	BBW251SKY	BBW351SKY	10A	BBW2101SKY	BBW3101SKY	15A	BBW2151SKY	BBW3151SKY
		30A	BBW2301Y	BBW3301Y	20A	BBW2201SKY	BBW3201SKY	30A	BBW2301SKY	BBW3301SKY	40A	BBW240SKY	BBW340SKY
		40A	BBW240Y	BBW340Y	30A	BBW2301SKY	BBW3301SKY	50A	BBW250Y	BBW350Y	50A	BBW250SKY	BBW350SKY
Rated Insulation Voltage		AC		500V		500V		500V					
JIS Rated Interrupting Capacity (sym)		AC		415V	1.5kA	2.5kA	200V	2.5kA	10kA				
		100V		2.5kA	2.5kA	10kA			10kA				
Dimensions		a		47	70	50		75					
		b		96		96		96					
		c		52		60		60					
		ca		67.6		75.6		75.6					
Weight of Standard Type		0.3kg		0.4kg		0.3kg		0.4kg					

Frame Size		60AF										
Type		BBW-60			BBW-60S							
Appearance					DIN rail mountable 							
Number of Poles		2P		3P		2P		3P				
Cat. No. & Rated Current (Nominal Ambient Temperature 40°C)		3A	BBW232Y	BBW332Y	60A	BBW260SKY	BBW360SKY	5A	BBW252Y	BBW352Y		
		10A	BBW2102Y	BBW3102Y				15A	BBW2152Y	BBW3152Y		
		20A	BBW2202Y	BBW3202Y				20A	BBW2202Y	BBW3202Y		
		30A	BBW2302Y	BBW3302Y				30A	BBW2302Y	BBW3302Y		
		40A	BBW2401Y	BBW3401Y				40A	BBW2401Y	BBW3401Y		
		50A	BBW2501Y	BBW3501Y				50A	BBW2501Y	BBW3501Y		
		60A	BBW260Y	BBW360Y								
Rated Insulation Voltage		AC		500V		500V		500V				
JIS Rated Interrupting Capacity (sym)		AC		415V	2.5kA	2.5kA	200V	5kA	10kA			
		100V		5kA	5kA	10kA			10kA			
Dimensions		a		47	70	50		75				
		b		96		96		96				
		c		52		60		60				
		ca		67.6		75.6		75.6				
Weight of Standard Type		0.3kg		0.4kg		0.3kg		0.4kg				

Frame Size		100AF			400AF					
Type		BBW-100			BBW-400					
Appearance		DIN rail mountable 								
Number of Poles		2P		3P		2P		3P		
Cat. No. & Rated Current (Nominal Ambient Temperature 40°C)		20A	BBW2203KY	BBW3203KY	250A	BBW22501KY	BBW32501KY	300A	BBW23001KY	BBW33001KY
		30A	BBW2303KY	BBW3303KY	350A	BBW2350KY	BBW3350KY	400A	BBW2400KY	BBW3400KY
		40A	BBW2402KY	BBW3402KY						
		50A	BBW2502KY	BBW3502KY						
		60A	BBW2601KY	BBW3601KY						
		75A	BBW275KY	BBW375KY						
		100A	BBW2100KY	BBW3100KY						
Rated Insulation Voltage		AC		500V		600V		600V		
JIS Rated Interrupting Capacity (sym)		AC		415V	5kA	25kA	200V	25kA	50kA	
		100V		25kA	25kA	50kA			50kA	
Dimensions		a		75	140 [148]	260 [349]		103		
		b		96		135		135		
		c		60		103		103		
		ca		75.6		135		135		
Weight of Standard Type		0.5kg		0.5kg		4.0kg		4.6kg		



Note 1) Install breakers with BBW-30, BBW-30C, BBW-50, BBW-50S, BBW-60, BBW-60S, BBW-100 within ±10° of perpendicular.



Note 2) When using 3-poles breaker for 1Ø 3W, neutral conductor cannot have open-phase protection.

Note 3) Please select conformed wire which suit to rated current.

Note 4) Dimensions with [ ] is the measurement including bar terminal.

## •Earth Leakage Breaker [BKW Type]

Frame Size	30AF					
Type	BKW-30			BKW-30C		
Appearance						
Phase and Wiring Configuration	1φ2W		3φ3W 1φ3W		1φ2W	
Number of Poles	2P		3P		3P	
Cat. No. & Rated Current (Nominal Ambient Temperature 40°C)	3A	BKW23□Y	BKW33□Y	5A	BKW25□CKY	BKW35□CKY
	5A	BKW25□Y	BKW35□Y	10A	BKW210□CKY	BKW310□CKY
	10A	BKW210□Y	BKW310□Y	15A	BKW215□CKY	BKW315□CKY
	15A	BKW215□Y	BKW315□Y	20A	BKW220□CKY	BKW320□CKY
	20A	BKW220□Y	BKW320□Y	30A	BKW230□CKY	BKW330□CKY
	30A	BKW230□Y	BKW330□Y			
Rated Voltage (AC V)	100-200V Dual use					
High Speed Type	Rated Sensitivity Current (mA)	15, 30		15, 30		15, 30, 100
	Operating Time (sec.)	0.1		0.1		0.1
Leakage Indication Method	Mechanical button					
JIS Rated Interrupting Capacity (sym)	AC	415V	-		-	
		200V	2.5kA		2.5kA	
		100V	2.5kA		2.5kA	
Dimensions	a	70		50		75
	b	96		96		
	c	52		60		
	ca	67.6		75.6		
Weight of Standard Type	0.4kg		0.5kg		0.4kg	0.5kg



Frame Size	50AF					
Type	BKW-50			BKW-50C		
Appearance						
Phase and Wiring Configuration	1φ2W		3φ3W 1φ3W		1φ2W	
Number of Poles	2P		3P		3P	
Cat. No. & Rated Current (Nominal Ambient Temperature 40°C)	20A	BKW220□1Y	BKW320□1Y	15A	BKW215□1CKY	BKW315□1CKY
	30A	BKW230□1Y	BKW330□1Y	20A	BKW220□1CKY	BKW320□1CKY
	40A	BKW240□Y	BKW340□Y	30A	BKW230□1CKY	BKW330□1CKY
	50A	BKW250□Y	BKW350□Y	40A	BKW240□CKY	BKW340□CKY
				50A	BKW250□CKY	BKW350□CKY
Rated Voltage (AC V)	100-200V Dual use					
High Speed Type	Rated Sensitivity Current (mA)	15 (below 30A), 30, 100 (above 40A)		15, 30		
	Operating Time (sec.)	0.1		0.1		
Leakage Indication Method	Mechanical button					
JIS Rated Interrupting Capacity (sym)	AC	415V	-		-	
		200V	2.5kA		25kA	
		100V	2.5kA		25kA	
Dimensions	a	70		50		75
	b	96		96		
	c	52		60		
	ca	67.6		75.6		
Weight of Standard Type	0.4kg		0.5kg		0.4kg	0.5kg



■ Rated Voltage Applicable Range

Rated voltage	Applicable Voltage Range
100-200V dual use	80-242V

■ Cat. No. □ Depends on the sensitivity current  
2:15mA 3:30mA 4:100mA 9:100-200-500mA Switchover

## •Earth Leakage Breaker [BKW Type]

Frame Size	50AF			60AF		
Type	BKW-50S		BKW-60		BKW-60S	
Appearance						
Phase and Wiring Configuration	1φ2W		3φ3W 1φ3W		1φ2W	
Number of Poles	2P		3P		3P	
Cat. No. & Rated Current (Nominal Ambient Temperature 40°C)	15A	BKW215□1SKY	BKW315□1SKY	15A	BKW215□Y	BKW315□Y
	20A	BKW220□1SKY	BKW320□1SKY	20A	BKW220□Y	BKW320□Y
	30A	BKW230□1SKY	BKW330□1SKY	30A	BKW230□Y	BKW330□Y
	40A	BKW240□SKY	BKW340□SKY	40A	BKW240□Y	BKW340□Y
	50A	BKW250□SKY	BKW350□SKY	50A	BKW250□Y	BKW350□Y
				60A	BKW260□Y	BKW360□Y
Rated Voltage (AC V)	100-200V Dual use			100-200V Dual use		
High Speed Type	Rated Sensitivity Current (mA)	15, 30, 100 (2P)		15 (below 30A) 30, 100 (above 40A)		30, 100 (2P)
	Operating Time (sec.)	0.1		0.1		0.1
Leakage Indication Method	Mechanical button					
JIS Rated Interrupting Capacity (sym)	AC	415V	-		-	
		200V	10kA		5kA	
		100V	10kA		5kA	
Dimensions	a	50		75		70
	b	96		96		96
	c	60		60		52
	ca	75.6		67.6		75.6
Weight of Standard Type	0.4kg		0.5kg		0.4kg	0.5kg

Frame Size	100AF		400AF		
Type	BKW-100		BKW-400		
Appearance					
Phase and Wiring Configuration	1φ2W		3φ3W 1φ3W		
Number of Poles	2P		3P		
Cat. No. & Rated Current (Nominal Ambient Temperature 40°C)	60A	BKW260□1KY	BKW360□1KY	250A	BKW3250□1KY
	75A	BKW275□KY	BKW375□KY	300A	BKW3300□1KY
	100A	BKW2100□KY	BKW3100□KY	350A	BKW3350□KY
				400A	BKW3400□KY
Rated Voltage (AC V)	100-200V Dual use		100-200-415V Dual use		
High Speed Type	Rated Sensitivity Current (mA)	30		30, 100-200-500	
	Operating Time (sec.)	0.1		0.1	
Leakage Indication Method	Mechanical button				
JIS Rated Interrupting Capacity (sym)	AC	415V	-		25kA
		200V	25kA		50kA
		100V	25kA		50kA
Dimensions	a	75		140 [148]	
	b	96		260 [349]	
	c	60		103	
	ca	75.6		135	
Weight of Standard Type	0.6kg		0.6kg		4.8kg

- Note 1) When using 3-poles breaker for 1φ3W configuration apply voltage to two end terminal. In this case neutral conductor cannot have open-phase protection.
- Note 2) When using on frequency control circuit (inverter) be sure to install breaker on primary side of inverter.
- Note 3) Breaker can be connected in reverse. However do not reverse connect 400 when used on a 415V circuit.
- Note 4) Install BKW-30, BKW-30C, BKW-50, BKW-50C, BKW-50S, BKW-60, BKW-60S, BKW-100 within ±10° of perpendicular.
- Note 5) Please select conformed wire which suit to related current.
- Note 6) Dimensions with ( ) is the measurement including bar terminal.

1 BBW-30, BBW-50, BBW-60, BKW-30, BKW-50, BKW-60

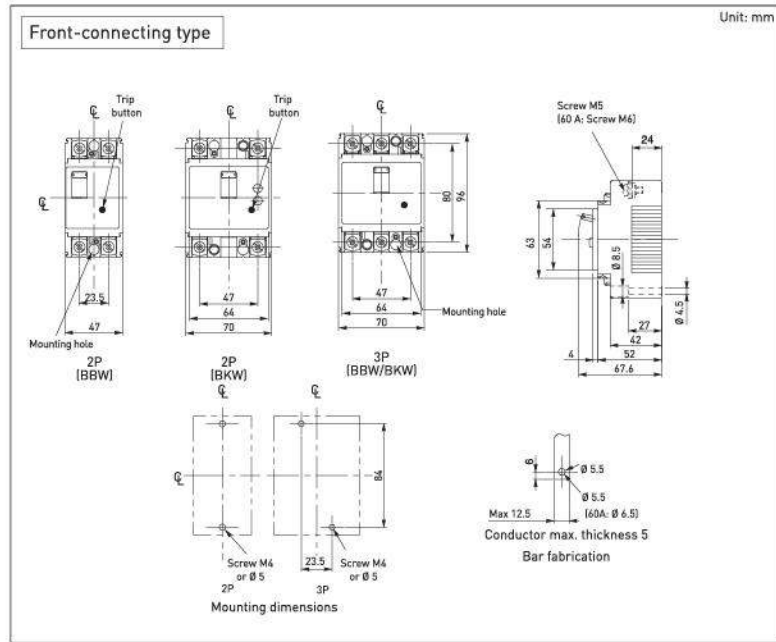

2 BBW-30C, BBW-50S, BBW-60S, BKW-30C, BKW-50C, BKW-50S, BKW-60S

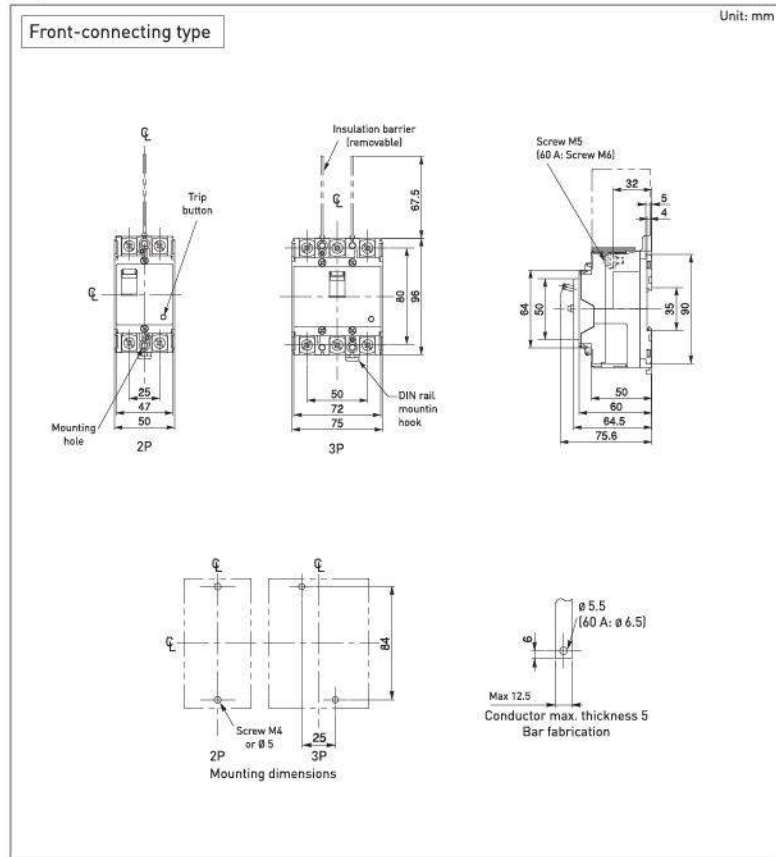

3 BBW-100, BKW-100

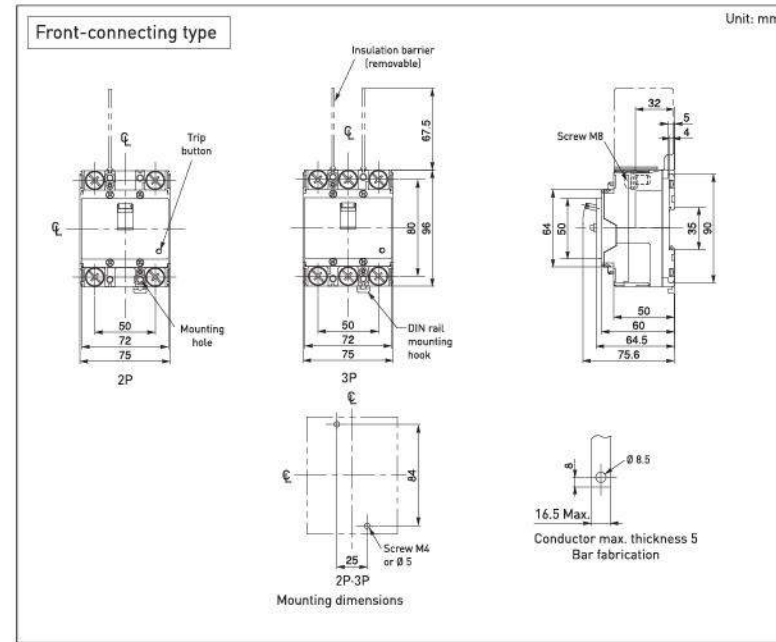

4 BBW-400, BKW-400

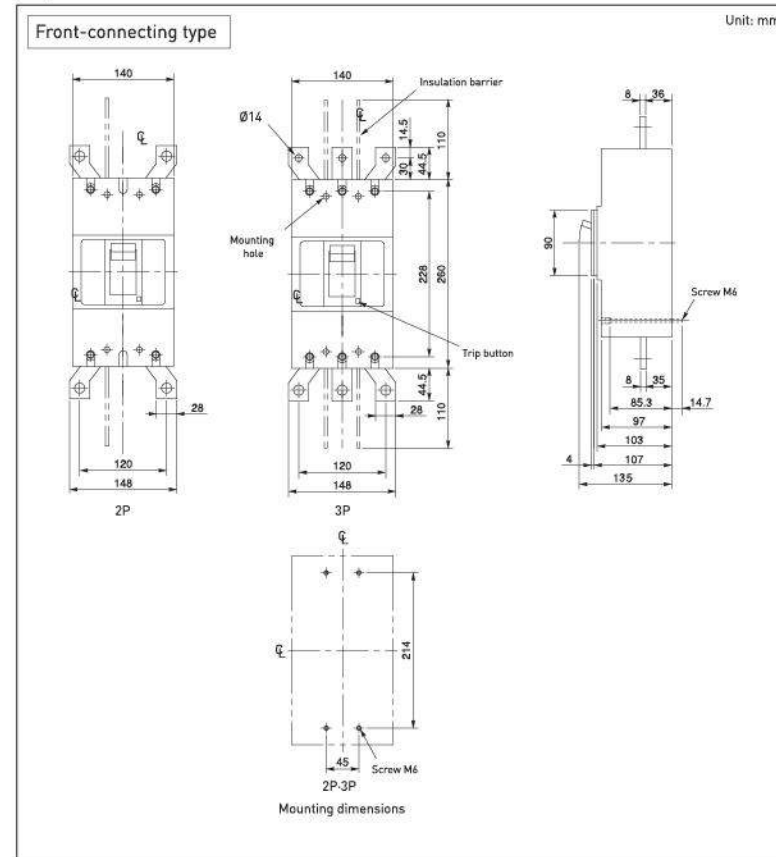

■ Cautions concerning the operating environment

Keep humidity at or below 85%RH

Ambient temperature: -10°C to +60°C  
 Note: Range is -10°C to +50°C for residential panel breakers  
 Relative humidity: 45% to 85%  
 Maximum elevation: 2000m above sea level

- If temperature exceeds 40°C, refer to the current rating table when specifying current rating of the breaker.
- If installed outdoors or in a location exposed to moisture, the breaker must be housed in a suitable enclosure. (Do not use in locations where dew or other condensation will form).
- It is recommended that the breaker be installed in a location not exposed to direct sunlight, as this can result in incorrect operation.

- The breaker must be installed in a suitable enclosure for use in a location exposed to dirt or dust, etc.
- Avoid installation in locations with acidic or alkaline atmospheres, such as chemical plants or breweries, etc.
- Avoid installation in locations exposed to rainwater or water spray, etc.
- Avoid installation in locations exposed to vibration, shock, or impact, etc.

■ Cautions concerning installation

Although perpendicular installation of breakers is recommended, installation is also possible as indicated below.

Overload current tripping method	Magnetic	Within ±10° of perpendicular
	Thermal, Thermal and magnetic	No restrictions on installation direction

Installation orientation for breakers with magnetic trip.

Side view: 10°±10°

Front view: Power supply side

When drilling holes or stripping insulation, cover the breaker with masking tape or paper to prevent sawdust and other foreign matter from entering the breaker mechanism.

■ Cautions concerning connections

1. Connection of electrical wires

- When connecting stranded wire, do not solder or bind the ends of the wire.
- Tighten the electrical wires securely. If the wires are not connected securely, overheating of terminals could cause a fire. If the neutral pole of a single-phase, three-wire breaker is not connected securely, an incorrect voltage could cause damage to the load.
- Do not lubricate the screws. Lubrication will reduce the friction of the screws and make it easier for them to come loose, which can result in overheating.
- Lubricating oil can also cause excessive stress on the screws, even when tightened to the specified torque, thus resulting in damage to the screws.
- Connect wires so that they run parallel.
- Select a wire size suitable to carry the rated current of the load.

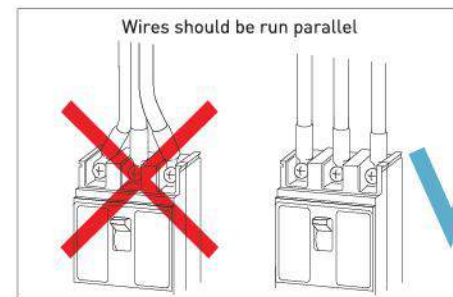

- When connecting stranded wire, separate the strands before inserting them into the terminal.
- 
- Single wire    Lug terminal    Stranded wire

2. Connection of MCCB terminals under 50AF

- When connecting directly to a terminal, insert the single wire or stranded wire straight into the terminal and then tighten to the specified torque. It is also possible to use commercially available lug or bar terminals.

	Single wire	Stranded wire
M5	ø1.6 & ø1.6mm	3.5mm <sup>2</sup> & 3.5mm <sup>2</sup>
	ø1.6 & ø2.0mm	3.5mm <sup>2</sup> & 5.5mm <sup>2</sup>
	ø1.6 & ø2.6mm	3.5mm <sup>2</sup> & 8mm <sup>2</sup>
	ø2.0 & ø2.0mm	5.5mm <sup>2</sup> & 5.5mm <sup>2</sup>
	ø2.0 & ø2.6mm	3.5mm <sup>2</sup> & 8mm <sup>2</sup>
	ø2.6 & ø2.6mm	8mm <sup>2</sup> & 8mm <sup>2</sup> 8mm <sup>2</sup> & 14mm <sup>2</sup>

After usage of breakers begins, perform regular inspections to maintain rated performance and prevent failures

Recommended replacement frequency  
 Circuit breakers: 15 years  
 Leakage breakers: 15 years  
 Source: "Investigation related to recommended replacement frequency for low-voltage equipment"  
 Japan Electrical Manufacturers' Association

Regular inspection guidelines

Environment	Regular inspection guideline (10-year period following installation)
Location where air is always clean and dry	Once every 2 to 3 years
Indoor location with little dust and no corrosive gases	Once each year
Location with little dust where air contains impurities (0.1 ppm or greater) such as sulfurous acid, hydrogen sulfide, salt, or high humidity	Once every 6 months

Type	Inspection location	Inspection item	Notes
Common	Top of breaker, power supply side	Check for problems such as dust accumulation and oil buildup.	After confirming that no power supply voltage is being applied, use cleaner to wipe away any dust and then wipe away any remaining grime with a clean, dry rag.
	Exhaust opening	Check for evidence indicating that the breaker has been tripped by overcurrent in the past.	If there is clear evidence of overvoltage, such as black soot or melted metal, replace the breaker with a new one.
	Terminals	<ul style="list-style-type: none"> <li>• Tighten terminal screws to ensure they are not loose.</li> <li>• Check for evidence indicating abnormally high temperatures or damage due to humidity or corrosive gas.</li> </ul>	<ul style="list-style-type: none"> <li>• Apply appropriate torque when tightening.</li> <li>• Sight discoloration of the terminal area is not a problem. If the discoloration is extreme or if the insulation is damaged. However, replace the breaker with a new one.</li> </ul>
	Handle	Confirm that the breaker closes and opens smoothly.	If the breaker is normally closed, open and close it a few times to ensure stable contact resistance and prevent overheating.
	Body	Check to make sure that the temperature of the breaker body does not exceed 70°C and no smoke or odor is produced when electrical current is flowing.	If there is anything amiss, replace the breaker with a new one.
ELB	Test button	Use the test button to confirm that the breaker operates properly. (When not testing the breaker, avoid using the test button to switch the handle to the off position).	<ul style="list-style-type: none"> <li>• Test the breaker about once each month.</li> <li>• When performing operation inspections, also measure using a leak checker to ensure that the current sensitivity and operation time are normal.</li> </ul>

■ Cautions when measuring insulation resistance

- For the places marked with a triangle (Δ) in the table at right, measuring the insulation resistance will not cause damage, but the insulation resistance meter reading will be approximately zero due to the internal circuit. To measure the insulation resistance between wires, first remove the wires from the terminals.
- For leakage breakers or breakers with leakage alarms equipped with the meg measurement switch as an internal function, measurement is possible if the handle is the off position.
- After reconnecting wires, switch the handle to the on position and press the test button to confirm the breaker is operating properly.

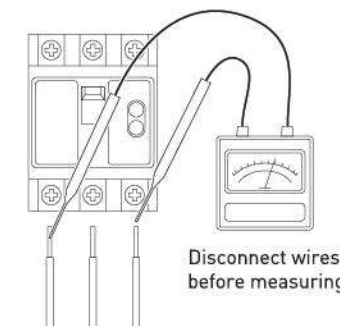

Handle position	Insulation resistance measurement (500 V or less)	
	On	Off
Between charger and ground	○	○
Between left and middle poles and between middle and right poles	○	○
Between left and right poles	Power supply side	△
	Load side	△
Between power supply and load terminals	—	○



Great protection against corrosion and high durability  
Labor-saving in installing pipe

## WHITE CONDUIT



Superior galvanizing by in-line hot-dip process for greater protection against corrosion. Finished with durable and clear anti-corrosion coating for higher protection outside and higher grade epoxy coating inside.

CROSS-SECTIONAL VIEW OF Panasonic WHITE CONDUIT

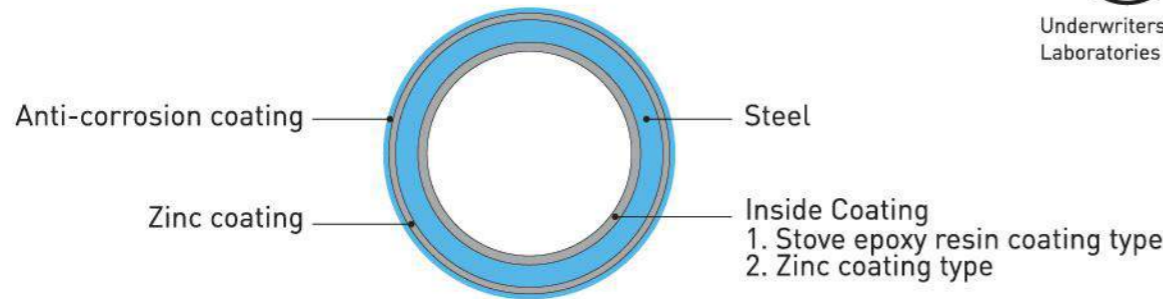

Underwriters Laboratories Inc.®

### Features

#### 1. Easy and accurate bending

Panasonic WHITE CONDUIT is made of high quality steel and processed by high frequency induction welding to prevent cracking when bend.

#### 2. Easy wire pushing and pulling

The high-grade stove epoxy resin coating on the inside wall makes wire-pulling easy, and protects against corrosion.

#### 3. Easy coupling and fast installation

Precise, sharp threads cut by automated machinery mean fast and easy installation. Precise thread also makes our conduit virtually moisture-tight.

#### 4. High corrosion resistance

Pure zinc coating on the exterior wall and stove epoxy resin finish on the inside protects WHITE CONDUIT from corrosion, even by harsh chemicals and sea air.

#### 5. Uniform quality

Flat steel is rolled, zinc-coated and threaded in one continuous automated process for uniform high quality.

## WHITE CONDUIT

### ANSI/UL

#### EMT (Electrical Metallic Tubing)

Listed by "UL" File No. E-44051

UL 797

Item No.	Size (inch)	Outside Diameter (mm)	Nominal Wall Thickness (mm)	Length (mm)	Nominal Weight (kg/pc)	Primary Bundle (pcs)	Master Bundle (pcs)
DWE012Y	1/2	17.93	1.07	3,048	1.46	10	500
DWE034Y	3/4	23.42	1.24	3,048	2.21	10	300
DWE100Y	1	29.54	1.45	3,048	3.08	5	200
DWE114Y	1-1/4	38.35	1.65	3,048	4.74	5	125
DWE112Y	1-1/2	44.20	1.65	3,048	5.49	5	100
DWE200Y	2	55.80	1.65	3,048	6.99	3	75
DWE212Y	2-1/2	73.03	1.83	3,048	9.80	-	40
DWE300Y	3	88.90	1.83	3,048	11.99	-	30
DWE312Y	3-1/2	101.60	2.11	3,048	15.80	-	20
DWE400Y	4	114.30	2.11	3,048	17.81	-	20

#### IMC (Intermediate Metal Conduit)

Listed by "UL" File No. E-62193

UL 1242

Item No.	Size (inch)	Outside Diameter (mm)	Nominal Wall Thickness (mm)	Length (mm)	Nominal Weight (kg/pc)	Primary Bundle (pcs)	Master Bundle (pcs)
DWM012Y	1/2	20.70	1.97	3,030	2.81	10	300
DWM034Y	3/4	26.14	2.10	3,030	3.81	5	250
DWM100Y	1	32.77	2.35	3,025	5.40	5	125
DWM114Y	1-1/4	41.59	2.41	3,025	7.17	3	75
DWM112Y	1-1/2	47.81	2.54	3,025	8.80	3	75
DWM200Y	2	59.93	2.67	3,025	11.61	-	50
DWM212Y	2-1/2	72.56	3.81	3,010	20.00	-	40
DWM300Y	3	88.29	3.81	3,010	24.63	-	30
DWM312Y	3-1/2	100.86	3.81	3,005	28.53	-	20
DWM400Y	4	113.40	3.81	3,005	31.75	-	15

ANSI/UL

**RSC (Rigid Steel Conduit/ Hot-Dip Galvanized Outside and Epoxy Resin Inside)**

Listed by "UL" File No. E-157617

UL 6

Item No.	Size (inch)	Outside Diameter (mm)	Nominal Wall Thickness (mm)	Length (mm)	Nominal Weight (kg/pc)	Primary Bundle (pcs)	Master Bundle (pcs)
DWR012Y	1/2	21.34	2.64	3,030	3.72	10	300
DWR034Y	3/4	26.67	2.72	3,030	4.94	5	250
DWR100Y	1	33.40	3.20	3,025	7.30	5	125
DWR114Y	1-1/4	42.16	3.38	3,025	9.89	3	75
DWR112Y	1-1/2	48.26	3.51	3,025	11.93	3	75
DWR200Y	2	60.33	3.71	3,025	15.88	-	50

**RSC (Rigid Steel Conduit/ Hot-Dip Galvanized both Inside and Outside)**

Listed by "UL" File No. E-157617

UL 6

Item No.	Size (inch)	Outside Diameter (mm)	Nominal Wall Thickness (mm)	Length (mm)	Nominal Weight (kg/pc)	Primary Bundle (pcs)	Master Bundle (pcs)
DWR012ZY	1/2	21.34	2.64	3,030	3.72	10	300
DWR034ZY	3/4	26.67	2.72	3,030	4.94	5	250
DWR100ZY	1	33.40	3.20	3,025	7.30	5	125
DWR114ZY	1-1/4	42.16	3.38	3,025	9.89	3	75
DWR112ZY	1-1/2	48.26	3.51	3,025	11.93	3	75
DWR200ZY	2	60.33	3.71	3,025	15.88	-	50
DWR212ZY	2-1/2	73.03	4.90	3,010	25.36	-	40
DWR300ZY	3	88.90	5.21	3,010	32.98	-	30
DWR312ZY	3-1/2	101.60	5.46	3,005	39.92	-	20
DWR400ZY	4	114.30	5.72	3,005	46.72	-	15
DWR500ZY	5	141.30	6.22	2,995	63.50	-	10
DWR600ZY	6	168.28	6.76	2,995	83.46	-	5

**Flexible Conduit**

Item No.	Size (inch)	Outside Diameter (mm)	Standard pack (m/Roll)	Weight (kg/pc)
DME012	1/2	21.84 ~ 23.37	30	7.80
DME034	3/4	26.54 ~ 28.07	30	9.70
DME100	1	33.02 ~ 35.05	15	5.80



**BS31**

**Threaded Conduit – Medium/ Heavy protection (Class 3)**

BS31: 1940

Item No.	Size (inch)	Outside Diameter (mm)	Nominal Wall Thickness (mm)	Length (mm)	Nominal Weight (kg/pc)	Primary Bundle (pcs)	Master Bundle (pcs)
DWB0343S	3/4	18.92	1.60	3,048	2.11	10	350
DWB0343L				3,810	2.63	10	350
DWB1003S	1	25.27	1.60	3,048	2.90	10	250
DWB1003L				3,810	3.61	10	250
DWB1143S	1-1/4	31.62	1.60	3,048	3.69	7	210
DWB1143L				3,810	4.59	7	210
DWB1123S	1-1/2	37.96	1.80	3,048	5.00	5	150
DWB1123L				3,810	6.23	5	150
DWB2003S	2	50.66	2.00	3,048	7.49	3	90
DWB2003L				3,810	9.32	3	90

**BS4568**

**Threaded Conduit – Medium/ Heavy protection (Class 3)**

BS4568: Part 1: 1970

Item No.	Size (inch)	Outside Diameter (mm)	Nominal Wall Thickness (mm)	Length (mm)	Nominal Weight (kg/pc)	Primary Bundle (pcs)	Master Bundle (pcs)
DWB0203	20	19.85	1.60	3,750	2.72	10	350
DWB0253	25	24.80	1.60	3,750	3.48	10	250
DWB0323	32	31.80	1.60	3,750	4.54	7	210

**Heavy Protection (Class 4)**

BS4568: Part 1: 1970

Item No.	Size (inch)	Outside Diameter (mm)	Nominal Wall Thickness (mm)	Length (mm)	Nominal Weight (kg/pc)	Primary Bundle (pcs)	Master Bundle (pcs)
DWB0204	20	19.85	1.60	3,750	2.92	10	350
DWB0254	25	24.80	1.60	3,750	3.71	10	250
DWB0324	32	31.80	1.60	3,750	4.84	7	210

Plain Conduit (Threadless)

JIS C 8305

Item No.	Size (inch)	Outside Diameter (mm)	Nominal Wall Thickness (mm)	Length (mm)	Nominal Weight (kg/pc)	Primary Bundle (pcs)	Master Bundle (pcs)
DW819T	E19	19.1	1.20	3,660	1.94	10	400
DW825T	E25	25.4	1.20	3,660	2.62	10	250
DW831T	E31	31.8	1.40	3,660	3.84	7	175
DW839T	E39	38.1	1.40	3,660	4.64	5	125
DW851T	E51	50.8	1.40	3,660	6.24	3	75
DW863T	E63	63.5	1.60	3,660	8.94	-	50
DW875T	E75	76.2	1.80	3,660	12.09	-	40

Thin Wall Conduit (Threaded)

JIS C 8305

Item No.	Size (inch)	Outside Diameter (mm)	Nominal Wall Thickness (mm)	Length (mm)	Nominal Weight (kg/pc)	Primary Bundle (pcs)	Master Bundle (pcs)
DW119T	C19	19.1	1.60	3,660	2.53	10	400
DW125T	C25	25.4	1.60	3,660	3.44	10	250
DW131T	C31	31.8	1.60	3,660	4.36	7	175
DW139T	C39	38.1	1.60	3,660	5.27	5	125
DW151T	C51	50.8	1.60	3,660	7.11	3	75
DW163T	C63	63.5	2.00	3,660	11.10	-	50
DW175T	C75	76.2	2.00	3,660	13.40	-	40

Thick Wall Conduit (Threaded)/ Hot-Dip Galvanized Outside and Epoxy Resin Inside

JIS C 8305

Item No.	Size (inch)	Outside Diameter (mm)	Nominal Wall Thickness (mm)	Length (mm)	Nominal Weight (kg/pc)	Primary Bundle (pcs)	Master Bundle (pcs)
DW216T	G16	21.0	2.30	3,660	3.88	10	250
DW222T	G22	26.5	2.30	3,660	5.02	10	175
DW228T	G28	33.3	2.50	3,660	6.95	7	125
DW236T	G36	41.9	2.50	3,660	8.89	5	75
DW242T	G42	47.8	2.50	3,660	10.22	3	75
DW254T	G54	59.6	2.80	3,660	14.35	-	50
DW270T	G70	75.2	2.80	3,660	18.30	-	40
DW282T	G82	87.9	2.80	3,660	21.51	-	30
DW392T	G92	100.7	3.50	3,660	30.71	-	20
DW394T	G104	113.4	3.50	3,660	34.72	-	20

Thick Wall Conduit (Threaded)/ Hot-Dip Galvanized both Inside and Outside

JIS C 8305

Item No.	Size (inch)	Outside Diameter (mm)	Nominal Wall Thickness (mm)	Length (mm)	Nominal Weight (kg/pc)	Primary Bundle (pcs)	Master Bundle (pcs)
DWZ216T	G16	21.0	2.30	3,660	3.88	10	250
DWZ222T	G22	26.5	2.30	3,660	5.02	10	175
DWZ228T	G28	33.3	2.50	3,660	6.95	7	125
DWZ236T	G36	41.9	2.50	3,660	8.89	5	75
DWZ242T	G42	47.8	2.50	3,660	10.22	3	75
DWZ254T	G54	59.6	2.80	3,660	14.35	-	50
DWZ270T	G70	75.2	2.80	3,660	18.30	-	40
DWZ282T	G82	87.9	2.80	3,660	21.51	-	30
DWZ392T	G92	100.7	3.50	3,660	30.71	-	20
DWZ394T	G104	113.4	3.50	3,660	34.72	-	20

For your amenity and energy saving  
**FULL-2WAY REMOTE LIGHTING CONTROL SYSTEM**



**Simple, Efficient Lighting Control That Matches Your Needs**

**ECOLOGY**

Energy-saving white  
 Creating an Efficient  
 Lighting Environment

**AMENITY**

User-friendly

**SIMPLE**

Simple Design  
 and Labor-saving  
 Installation

**CONVENIENCE**

Minimal Design,  
 Minimum Maintenance

**FLEXIBILITY**

Reduced Total Cost

**Centralized Monitoring and Control**

Control and Monitor All Lighting  
 from a Central Location



**Functional Display of Lightning Status**

LED Displays Lightning Status

- ON: Red Light is lit



- OFF: Green Light is lit



**Timer and Sensor Control**

Connectable with Timer or Sensor Control  
 Equipments for Further Energy Saving



- Program Timer Unit



- Passive Infrared Ceiling Unit



- Daylight Sensor Unit

**Group Control**

Turn **ON** All Lights  
 in The Sales  
 Department

Turn **OFF** All Lights  
 in The Sales  
 Department



All Lights **ON**

All Lights **OFF**

**Pattern Control**

9:00 AM  
 Work Starts

Noon to  
 1:00 PM  
 Lunch Break

2:00 to  
 3:00 PM  
 Natural Light  
 Come from  
 Outside

6:00 PM  
 Work Finish



All Lights ON

Some Lights ON

All Lights OFF

**Dimmer Control**



100%

**The bigger the building, the more labor-saving the installation**

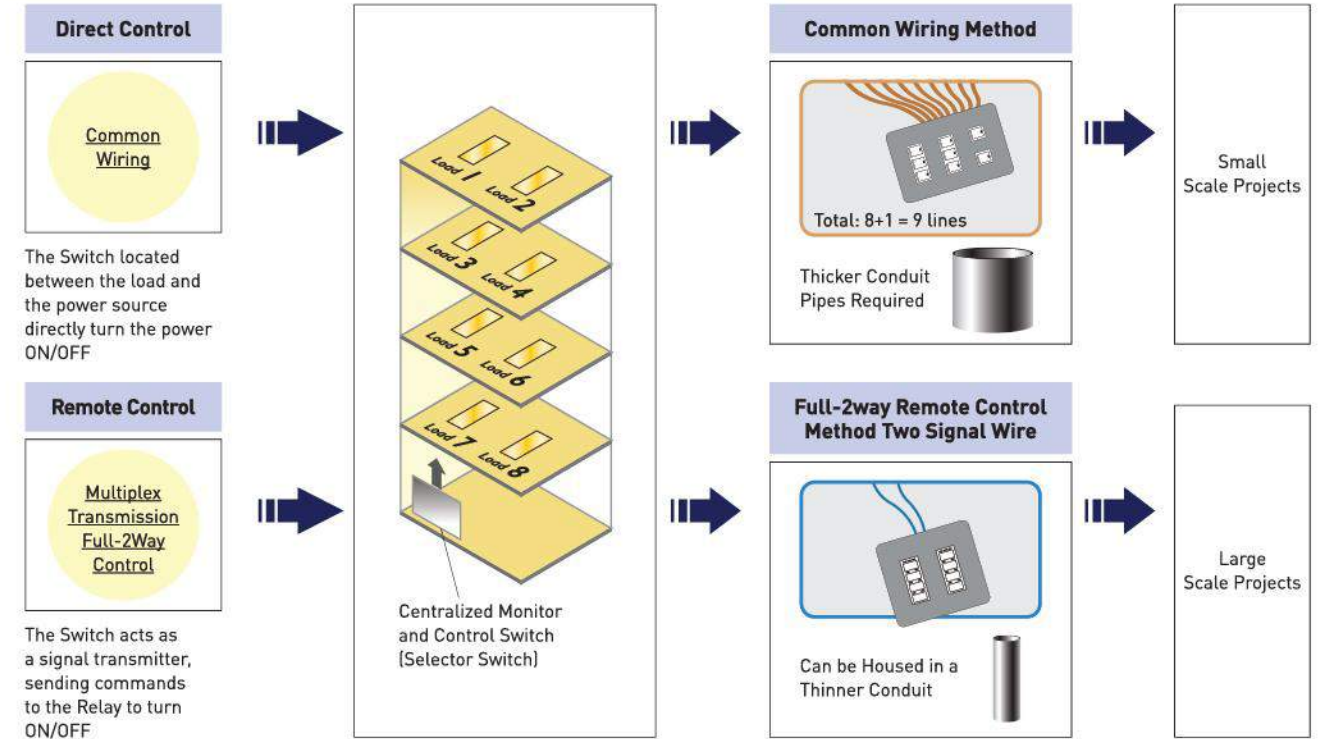

**Wiring diagram for Full-2Way remote control system**

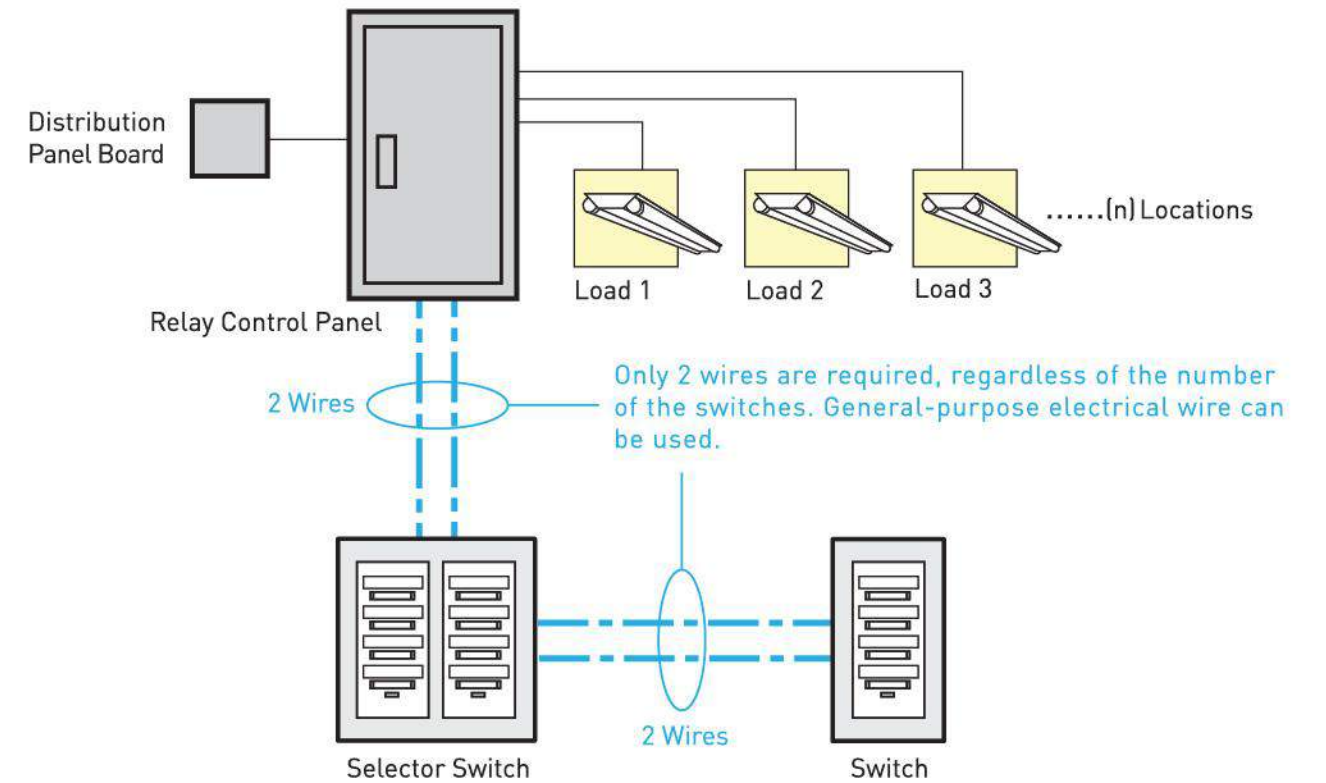

Flexible wiring systems for stationary loads. Select from four types according to the capacity you desire, from single-phase 20A to three-phase 100A

# FactoryLine

## Flexible power supply from the ceiling

Ceiling wiring systems capable of providing power for lighting & driving. You can change layout simply by reconnecting plugs to the ducts installed at the ceiling - it allows you to reduce time, labor, and cost significantly without major rewiring.

**FLEXIBLE**

**SAFETY**

**NICE VIEW**

**FLEXIBLE**

### No More Wiring-work After Layout Change.



**Basic advantages**

Simple layout change - just re-connect plugs at different positions. You can reduce labor, time & cost.

**Additional advantages**

You can add, reduce & relocate power supply easily. Just pull down lever, and turn the plugs to remove or connect.



**SAFETY**

### No more tripping over & damaging a cable on the floor.



**Basic advantages**

Wiring from the ceiling keeps the floor tidy. Plugs with breakers provide safety.

**Additional advantages**

No need to install breakers with distribution panels - it saves space.

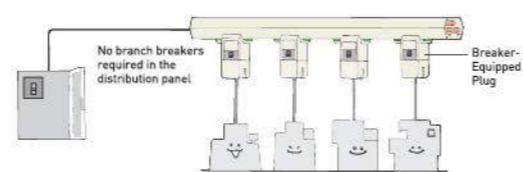

**NICE VIEW**

### It simplifies wiring & appearance. Effective for productivity improvement.



**Basic advantages**

You can keep ceiling & floor tidy, and appeal to visitors during factory tours.

**Additional advantages**

One single duct provides three-phase power supply & single-phase power supply - it allows one duct to supply power for machine-driving, conventional sockets and lighting. Factory Line 100/60 simplifies the entire wiring plan.

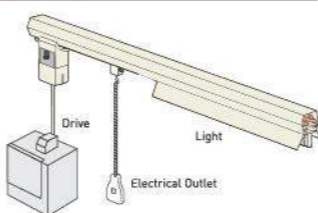

# FACTORY LINE SYSTEM

## Wide Lineup

Four types of main duct are available - 100A, 60A, 30A and 20A. You can combine them to create your own flexible wiring systems for factories.

For Main and Branch Lines

### Multi-purpose Factory Flexible wiring System - It provides three-phase & single-phase power supplies at a time.

#### Factory Line 100

- Three-phase power supply (100A max.)
- Single-phase power supply (20A max.) with breaker-equipped plug

Can be used simultaneously

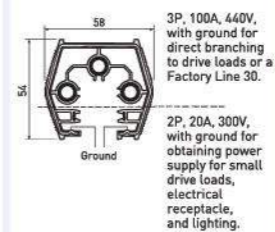
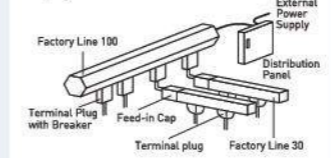

### Branching from the 3 wires of the upper level to Factory Line 30. [The rating in ( ) is of Factory Line 60]

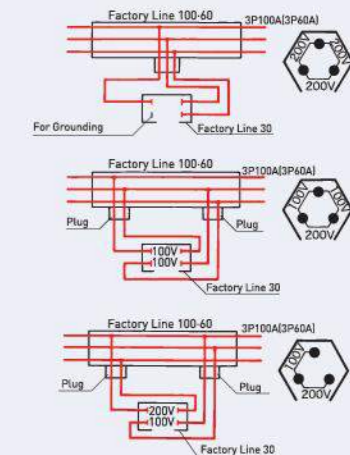

For Branch Lines

### Multi-purpose Factory Flexible wiring System - It provides three-phase & single-phase power supplies at a time.

#### Factory Line 60

- Three-phase power supply (60A max.)
- Single-phase power supply (20A max.) with breaker-equipped plug

Can be used simultaneously

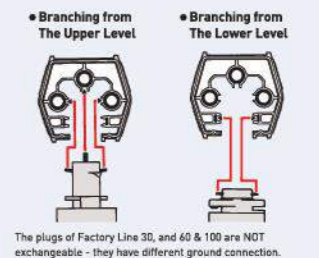
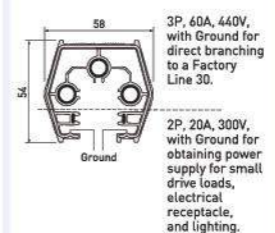
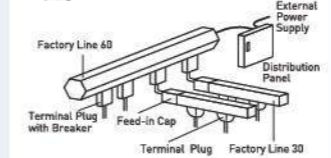

The plugs of Factory Line 30, and 60 & 100 are NOT exchangeable - they have different ground connection.

For Small-Scale Branch Lines

### Four wire Factory Flexible wiring System - It provides one or the other: three-phase circuit or two single-phase circuits.

#### Factory Line 30

- Three-phase power supply, one circuit (30A max.)
- Single-phase power supply, two circuits (30A max.)

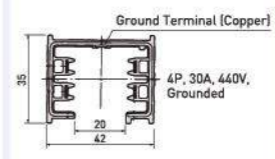
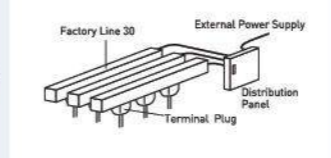

### Standard Power Supply Take-Off

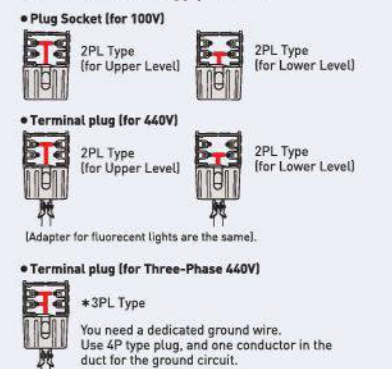

### Factory Flexible wiring System for small-scale branching - It provides one single-phase power supply circuit.

#### Factory Line 20

- Single-phase power supply (20A max.)

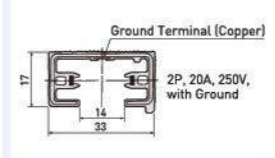
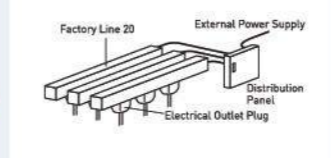

Factory Line 100/60

Factory Line 100/60 Main Unit (Cream-Gray Finish; Munsell 5Y7.2/1.4)	Cat. No.	Length & (mm)	Weight (kg)	Rating
Factory Line 100	DGHU2411	1,000	3.3	3P 100A 440V + 2P 20A 300V with Ground
	DGHU2412	2,000	6.6	
	DGHU2413	3,000	9.9	
Factory Line 60	DGHU2311	1,000	3.1	3P 60A 440V + 2P 20A 300V with Ground
	DGHU2312	2,000	6.1	
	DGHU2313	3,000	9.1	

	Cat. No.	Weight (kg)	Rating
<b>Feed-in Cap (Cream-Gray Finish)</b>	DGHU2421	1.1	3P 100A 440V + 2P 20A 300V with Ground
<b>Center Feed-in Joiner (Cream-Gray Finish)</b>	DGHU2422	2.4	
<b>Joiner (Cream-Gray Finish)</b>	DH2431	0.1	2P 20A 300V with Ground
<b>End Cap (Cream-Gray Finish)</b>	DH2423K	0.06	-
<b>Hanger (with Bolt)</b>	DH2451	0.18	-
<b>Terminal plug A (Cream-Gray Finish)</b>	DGHU2481	0.35	3P 30A 440V with Ground
<b>Terminal plug B (Cream-Gray Finish)</b>	DH2463	0.08	2P 15A 300V with Ground
<b>Locking plug socket (Cream-Gray Finish)</b>	DH2477	0.07	Ground 2P 15A 125V Locking
<b>Plug socket (Cream-Gray Finish)</b>	DH2461	0.07	Ground 2P 15A 125V
<b>Reel-Type plug socket (White Finish)</b>	DH24621W	0.7	for Twin Ground 2P 15A 125V
	DH24641W		for Twin Ground 2P 15A 125V Locking
<b>Hanger (with earthquake resistant reinforcement fixture)</b>	DH2452K1	0.03	-

Factory Line 30

Factory Line 30 Main Unit (Cream-Gray Finish; Munsell 5Y7.2/1.4)	Cat. No.	Length & (mm)	Weight (kg)	Rating
Factory Line 30	DGHU2711	1,000	1.6	4P 30A 440V with Ground
	DGHU2712	2,000	3.2	
	DGHU2713	3,000	4.8	

	Cat. No.	Name/Type	Weight (kg)	Rating
<b>Feed-in Cap (Cream-Gray Finish)</b>	DGHU2721	-	0.16	4P 30A 440V with Ground
<b>Center Feed-in Joiner (Cream-Gray Finish)</b>	DGHU2722	-	0.24	
<b>End Cap (Cream-Gray Finish)</b>	DH2723	-	0.01	-
<b>Joiner (Cream-Gray Finish)</b>	DGHU2731	-	0.08	4P 30A 440V with Ground
<b>Terminal Plug (Cream-Gray Finish)</b>	DGHU2781	2PS	0.08	2P 15A 440V with Ground
	DGHU2782	2PL		3P 15A 440V with Ground
	DGHU2783	3P		4P 15A 440V with Ground
※1 <b>Plug socket (Cream-Gray Finish)</b>	DH2773	S	0.05	Ground 2P 15A 125V
	DH2774	L		
※2 <b>Locking plug socket (Cream-Gray Finish)</b>	DH2791	S	0.05	Ground 2P 15A 125V Locking
	DH2792	L		
※2 <b>Reel-Type plug socket (White Finish)</b>	DH27751W	S	0.73	for Twin Ground 2P 15A 125V
	DH27761W	L		
	DH27781W	S		for Twin Ground 2P 15A 125V Locking
	DH27791W	L		
※2 <b>Hanger (with Bolt)</b>	DH2751	-	0.11	-
<b>Hanger (with earthquake resistant reinforcement fixture)</b>	DH2752K1	-	0.03	-

※1: 2P/3P/4P 15A 300V with Ground, Power Outlet for The Main Unit.  
 "L" (for the upper 2P conductors) and "S" (for the lower 2P conductors) plug are available in 2P type.  
 ※2: "L" (for the upper conductors) and "S" (for the lower conductors) plug are available.

Factory Line 20

Factory Line 20 Main Unit (Cream-Gray Finish; Munsell 5Y7.2/1.4)	Cat. No.	Length & (mm)	Weight (kg)	Rating
Factory Line 20	DGHU2611	1,000	0.79	2P 20A 250V with Ground
	DGHU2612	2,000	1.58	
	DGHU2613	3,000	2.37	

	Cat. No.	Weight (kg)	Rating
<b>Feed-in Cap (Cream-Gray Finish)</b>	DGHU2621K1	0.11	2P 20A 250V with Ground
<b>Center Feed-in Joiner (Cream-Gray Finish)</b>	DGHU2622K1	0.19	
<b>End Cap (Cream-Gray Finish)</b>	DH2623	0.006	-
<b>Joiner (Cream-Gray Finish)</b>	DGHU2631K1	0.1	2P 20A 250V with Ground
<b>Terminal Plug (Cream-Gray Finish)</b>	DGHU2683	0.05	2P 15A 250V with Ground
<b>Plug Sockets (with Ground) (Cream-Gray Finish)</b>	DH2670	0.04	Ground 2P 15A 125V
<b>Locking Plug Socket (Cream-Gray Finish)</b>	DH2671	0.04	2P 15A 125V
<b>Locking Plug Socket (with Ground) (Cream-Gray Finish)</b>	DH2684	0.04	Ground 2P 15A 125V Locking
<b>Reel-Type Plug Socket (with Ground) (White Finish)</b>	DH26751W	0.7	for Twin Ground 2P 15A 125V
	DH26771W		for Twin Ground 2P 15A 125V Locking
<b>Hanger (with Bolt)</b>	DH2651	0.13	-
<b>Hanger (without Bolt)</b>	DH2652	0.03	-

 **Factories**

You can get power from optimal location quickly even after layout change.

Factory Line 100



 **Retail Stores**

Supplying power for lighting & sockets at a time. Highly functional Factory Line 30, which offers two single phase circuits at a time, allows the store to have power for lighting and extra sockets. It also fits into modern, lightly equipped ceilings - the simple wiring produces spacious environment in the store.

Factory Line 30



 **Schools**

Two circuits can be supplied simultaneously from a single duct, making it possible to connect more devices and keeping floor clearer.

Factory Line 30



**[Others]**

 **Research Institutes & Laboratories**

One single duct (Factory Line 30) can provide many small capacity power supplies with different voltages & frequencies - it allows many applications.

 **Data Centers**

Factory Line 100, 60 and 30 can supply power to both 200V & 100V devices at a time on server racks. NO NEED FOR WIRING SPACE ON/UNDER FLOOR due to power supply from the ceiling.



Information about Panasonic Factory Line Systems is available at:

[www2.panasonic.biz/es/densetsu/haikan/ffs/en/](http://www2.panasonic.biz/es/densetsu/haikan/ffs/en/)

● Specification drawings, operation and installation manuals can also be downloaded.

# PHOTOVOLTAIC MODULE HIT®



Designed for higher energy production and long-term reliability, Panasonic HIT® ensures you a true peace of mind and satisfaction in your energy management.

## 1. 19.4% module efficiency

+25% more power from same area



HIT®: 15pcs x 325W = 4.87kW VS Standard\*: 15pcs x 260W = 3.9kW

## 2. High performance at high temperature

Up to +13% more generation in the day time

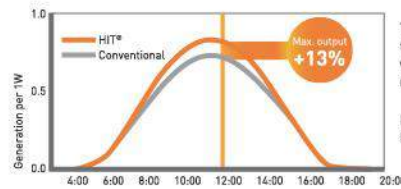

Total yield with a peak module temperature of 85°C, compared with a conventional crystalline module.

Measurement: 8 July 2013, Kaizuka City, Japan

## 3. More generation, higher profit

Helping you reach a higher final profit with your PV system

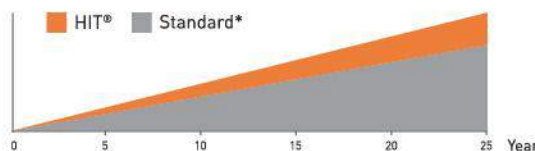

Standard\*: Conventional crystalline module with Pmax 260W

### Heterojunction technology

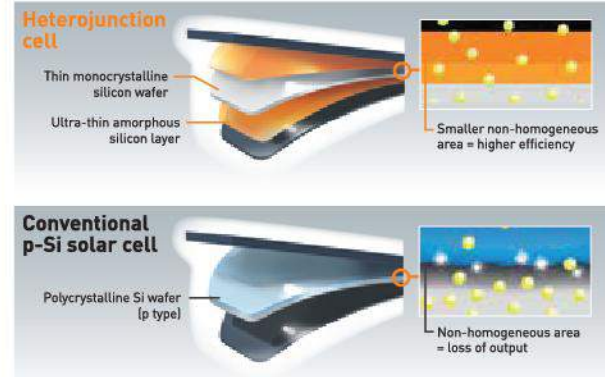

Unique water drainage

### HIT Series

<b>Model: N325 (VBHN325SJ47)</b>	
Module efficiency	<b>19.4%</b>
Output/m <sup>2</sup>	<b>194W/m<sup>2</sup></b>
Temperature coefficient	<b>0.29%/C</b>

Specification		
Max. power (Pmax)	[W]	325
Open circuit voltage (Voc)	[V]	69.6
Short circuit current (Isc)	[A]	6.03
Size	Weight	
W 1,053mm x H 1,590mm x D 35mm	18.5kg	



### MONO PERC Series

<b>Model: VBMS380AJ09</b>	
Module efficiency	<b>19.6%</b>
Output/m <sup>2</sup>	<b>196W/m<sup>2</sup></b>
Temperature coefficient	<b>0.39%/C</b>

Specification		
Max. power (Pmax)	[W]	380
Open circuit voltage (Voc)	[V]	48.5
Short circuit current (Isc)	[A]	10.22
Size	Weight	
W 992mm x H 1957mm x D 40mm	22.5kg	



### MONO Series

<b>Model: VBMS290AJ07</b>	
Module efficiency	<b>17.8%</b>
Output/m <sup>2</sup>	<b>178W/m<sup>2</sup></b>
Temperature coefficient	<b>0.39%/C</b>

Specification		
Max. power (Pmax)	[W]	290
Open circuit voltage (Voc)	[V]	39.1
Short circuit current (Isc)	[A]	9.62
Size	Weight	
W 992mm x H 1640mm x D 35mm	18.5kg	



# VENTILATING FANS & AIR MOVING EQUIPMENT

Providing you a breath of fresh air



# WHAT ARE THE INDOOR AIR QUALITY PROBLEMS EXISTING IN YOUR HOUSE?

Recently, many reports show that people are in poorer physical condition. It is because of high living density and usage of building or interior material which emit chemical substances in either new-built or reformed house, causing indoor air quality problems.

There are different symptoms, such as eyes/ sore throat, nausea, feeling unwell, skin irritation, headache, dizziness, breathing problem and so on. Furthermore, chemical substances like formaldehyde, can lead to the deterioration of allergic illness.

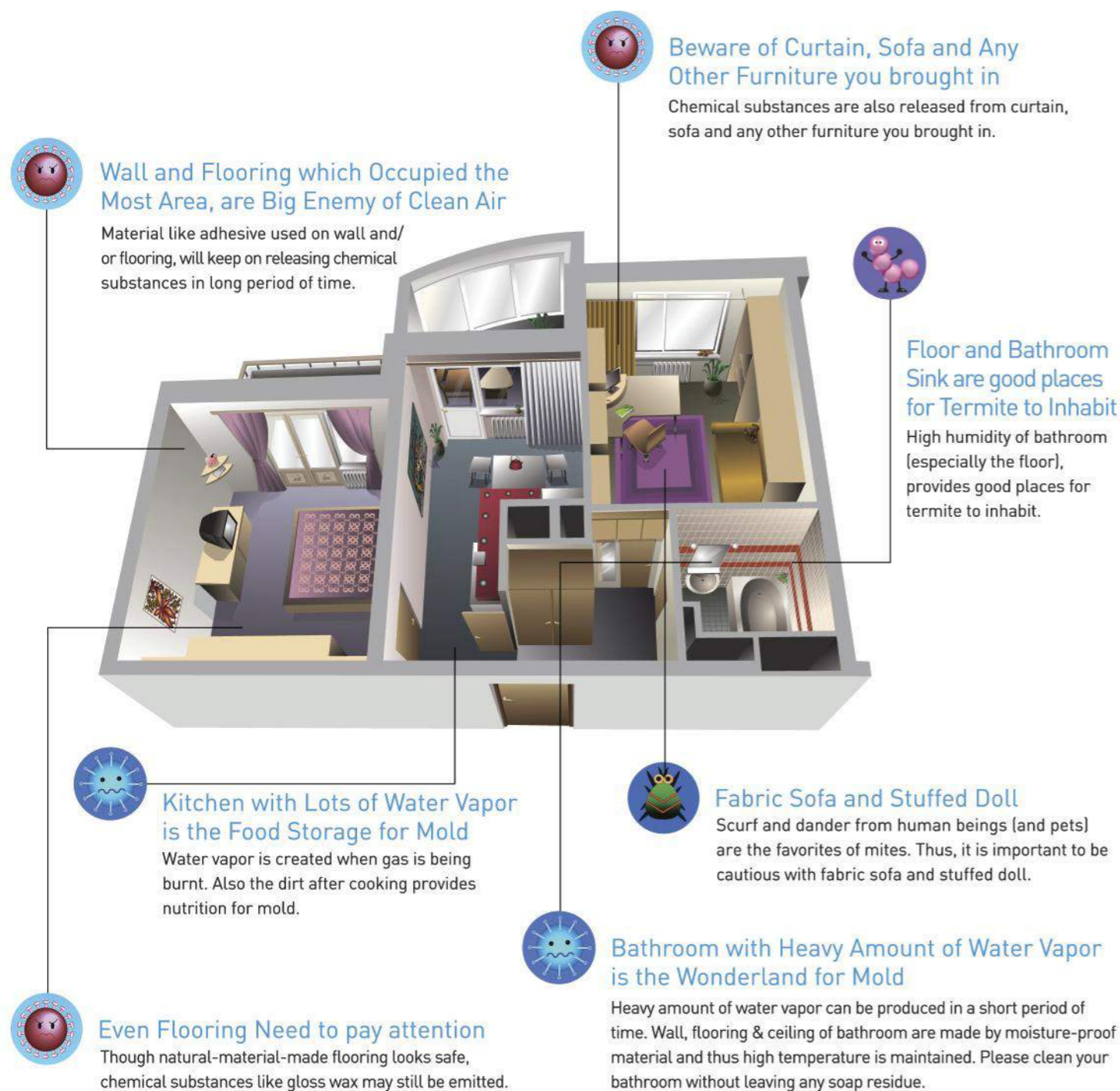

# INDOOR AIR PROBLEMS IN YOUR HOUSE



## Mites

There are around 30 types of mites found in a home normally. In general, most mites live without causing any harm to human beings. However, sting mites like Cheyletidae, blood-sucking mites like House Mite, and Dust Mite group which can cause allergen also exist.

## Temperature and Humidity for Mite Breeding

Mite breeds when temperature is over 20°C and humidity is over 60%

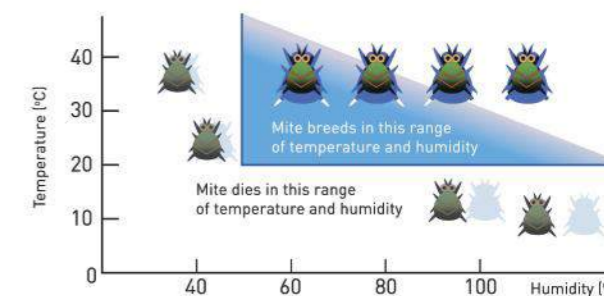

[Source: "Information of Residence and Home"; Environment Hygiene Section, Health and Welfare Department, Osaka Prefecture]



## Molds



Mold breeds faster when humidity increases, and nearly everything inside & outside our residence can provide nutrients for it. Not only mold is damaging our home appearance and creating bad smell, it also has bad effects on human body. Furthermore, mold increases during rainy season, and its spores fly around at the end of rainy season.



## Termite

It is common to find termite damages like wall crack, undulating eaves & roof, and even broken window/shutter. Comparing to termite which causes damage mainly under floor, home termite causes damage widely to whole house (till ceiling).



## Formaldehyde (HCHO)

Volatile organic compounds (VOC) like Formaldehyde which is generated from building material and/or home furniture. It is easily to cause indoor air pollution.

### Indoor Formaldehyde concentration was measured

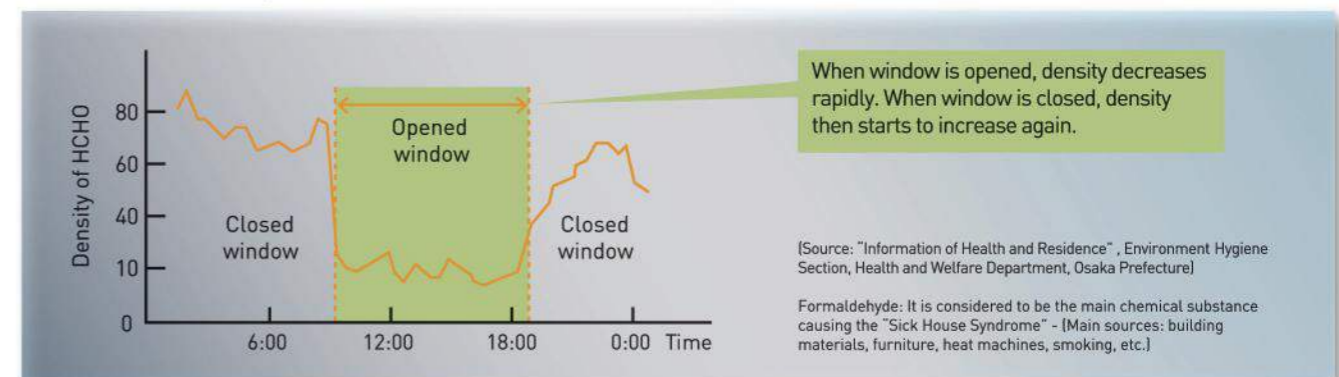



# IMPROVE INDOOR AIR QUALITY

## Ways to improve Indoor Air Quality

The first step to improve indoor air quality should reduce or remove the source of the pollutants. Unfortunately, indoor pollutant is virtually impossible to eliminate completely, creating the need for a second step - ventilation. Ventilation is divided into "Natural Ventilation" and "Mechanical Ventilation".

Natural ventilation is neither consistent nor reliable since it relies heavily on wind and weather conditions. Mechanical ventilation removes stale, moist, polluted air and replaces it with fresh outside air by using a fan.

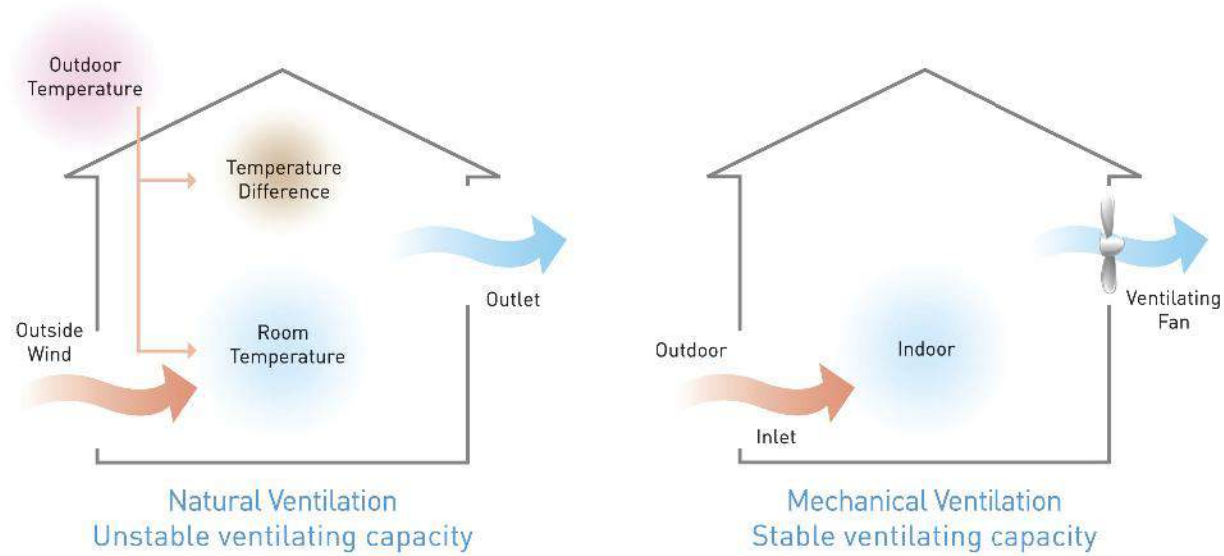

### Continuous Ventilation

Sometimes referred to as general, central, whole-house or primary ventilation. Continuous ventilation is used to remove stale air and provide fresh air on a slow, continuous basis.

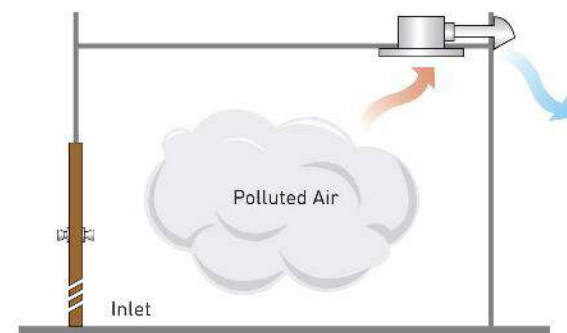

Enhance ventilation in the whole house to replace polluted air with fresh air by ventilation equipment.

# VENTILATION SCHEDULE

## The Number of Ventilating Fans Required

[A]: Room Size [m<sup>3</sup>] x [B]: Necessary Frequency of Ventilation Per Hour

[C]: Air Volume of Ventilating Fan [m<sup>3</sup>/h]

Note: Room size [A] is calculated from the following equation:  
 [A] = Floor area [sq. m. or sq. ft.] x Room height [m. or ft.]  
 If the room height exceeds 4 meters (13 feet), use 4 meters (13 feet) in the calculation regardless of the actual room height.

Values for [B] in above equation are given in the table on the below. These values were empirically found by the research scientists. Value for [C] in the above equation are given in our catalogs.

### Ventilation Schedule

	I: Type of room		II: Necessary frequency of ventilation per hour			
	I	II	I	II		
<b>Hotel</b>	Dance Hall	8	<b>Photo Studio</b>	Dark Room	10	
	Dining Hall	8		<b>School</b>	Laboratory	6
	Kitchen	15			Cooking Room	15
	Hallway	5			Auditorium	6
	Toilet	5			Gymnasium	8
	Lavatory	10			Toilet	12
	Boiler Room	20			Library	6
	Laundry	15			Classroom	6
	<b>Hospital</b>	Waiting Room			10	<b>Theatre</b>
Clinic		6	Hallway		6	
Ward		6	Smoking Room	12		
Bathroom		5	Toilet	10		
Office		6	Projection Booth	20		
Restaurant		8	Workroom	6		
Kitchen		15	Telephone Switch Board Room	6		
Gallery		5	<b>Factory</b>	Painting Room	20	
Toilet		10		Dynamo Room and Substation	20	
Boiler Room		10		Condenser Room	15	
Laundry		15		Office	6	
Operating Room		15	<b>Restaurant &amp; Snack Bar</b>	Restaurant	6	
Disinfecting Room		12		Kitchen	20	
Room for the Patients Receiving Medical Treatment for the Diseases of Respiratory Organs		10	<b>Office Building</b>	Office	6	
<b>Public Toilet</b>		20		Waiting Room	10	
				Conference Room	12	
<b>Vessel</b>	Passenger Room	6	Display Room	10		
			Toilet	10		
<b>Home</b>	Kitchen	15	<b>Rooms where poisonous or inflammable gas is produced</b>		more than 20	
	Parlor	6				
<b>Library</b>	Living Room	6				
	Reading Room	6				

# RECOMMENDED APPLICATION

Panasonic ventilating products can be used in various environment, such as residential house, offices and hotel

Ventilating fans installed throughout the home draw indoor pollutants and vent them outside. So, a continuous and balanced ventilation system brings you with fresh air.



## Office

Office also needs a good ventilation system to maintain constant and fresh airflow. Panasonic Cabinet Fan definitely provides you with a quiet and comfortable environment.



## FV-24CUR1/ FV-24CHR1 Sensor Series



Dimension  
Unit: mm

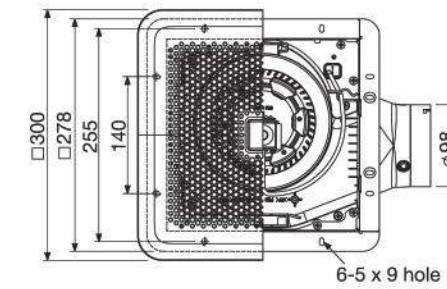

- Auto operation by motion sensor
- Off delay timer (15 minutes)
- HP (half pitch) motor with ball bearing
- Taper blade sirocco fan
- Curve-shaped backdraft shutter
- Super low noise level

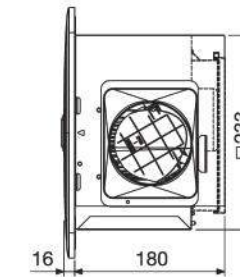

### Specification

Model No.	Hz	Power Consumption [W]	Air Volume		Noise [dB(A)]	Weight [kg]	Installation Space [mm]	Duct Size [mm]
			[CMH]	[CFM]				
FV-24CUR1	50	11	140	82	25	2.8	240 x 240	Ø100
FV-24CHR1	50	17	200	118	32	2.8	240 x 240	Ø100

Note: Values in Consumption and Noise are specified at Static Pressure of 0 Pa.

Performance Data  
(220V 50Hz)

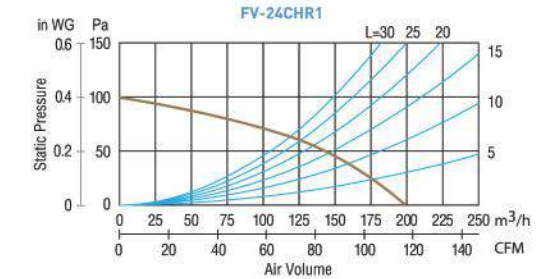
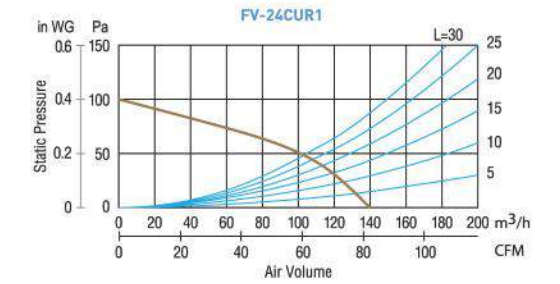

## FV-24CURV1/ FV-24CHR1 Sensor Series



Dimension  
Unit: mm

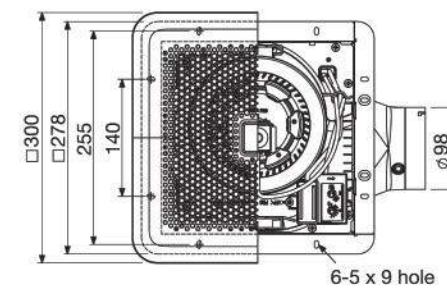

- Auto operation by motion sensor and humidity sensor
- Off delay timer (6 selections)
- HP (half pitch) motor with ball bearing
- Taper blade sirocco fan
- Curve-shaped backdraft shutter
- Super low noise level
- Humidity setting (45% - 95%)

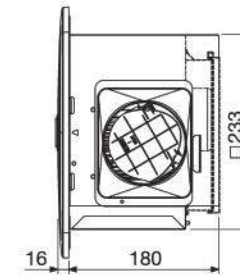

### Specification

Model No.	Hz	Power Consumption [W]	Air Volume		Noise [dB(A)]	Weight [kg]	Installation Space [mm]	Duct Size [mm]
			[CMH]	[CFM]				
FV-24CURV1	50	11	140	82	25	2.9	240 x 240	Ø100
FV-24CHR1	50	17	200	118	32	2.9	240 x 240	Ø100

Note: Values in Consumption and Noise are specified at Static Pressure of 0 Pa.

Performance Data  
(220V 50Hz)

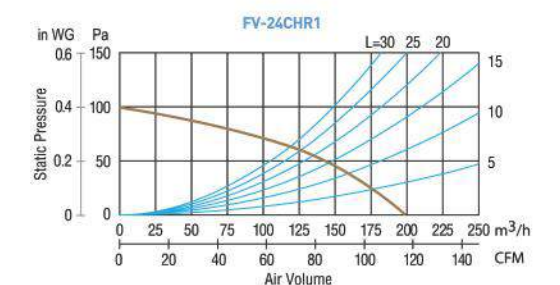
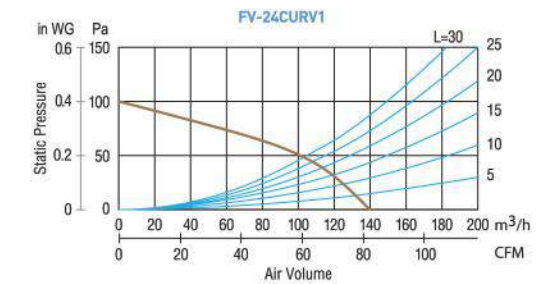

\* Local regulations concerning the installation of ventilation fans should be fulfilled.  
\* Installation methods please refer to the operation instruction.

## FV-17CU9/FV-24CU9/FV-24CD98/FV-24CH9



### Dimension

Unit: mm

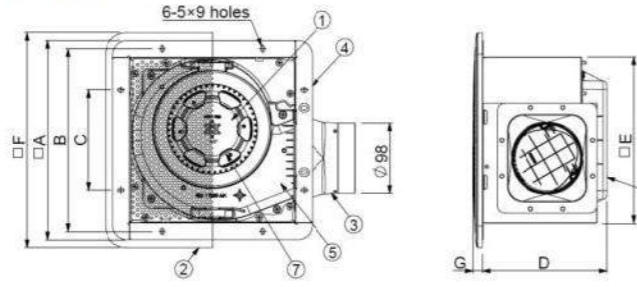

Model No.	A	B	C	D	E	F	G
FV-17CU9	214	194	84	164	170	230	13
FV-24CU9	278	255	140	175	233	300	13
FV-24CD9	278	255	140	175	233	300	13
FV-24CH9	278	255	140	175	233	300	13

### Specification

Model No.	Hz	Consumption [W]	R.P.M [min <sup>-1</sup> ]	Air Volume		Noise [dB(A)]	Weight [kg]	Installation Space [mm]
				[CMH]	[CFM]			
FV-17CU9	50	7.5	680	85	85	23.0	1.7	177x177
FV-24CU9	50	10.5	540	140	140	25.0	2.7	240x240
FV-24CD9	50	13.5	650	170	170	28.5	2.7	240x240
FV-24CH9	50	16.5	740	200	200	32.0	2.7	240x240

Note  
 \*The value of power consumption, air volume and noise are specified at static pressure of 0 Pa.  
 \*The value of noise level is measured at 1m apart from the left, the right and the directly below of product, then get the average of three values.

### Performance Curve

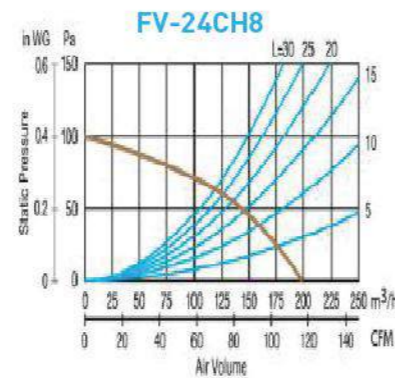
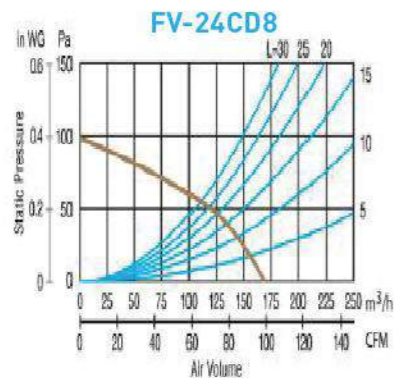
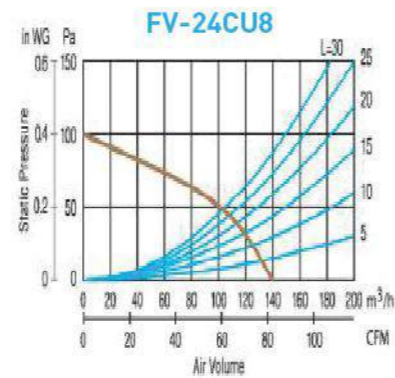
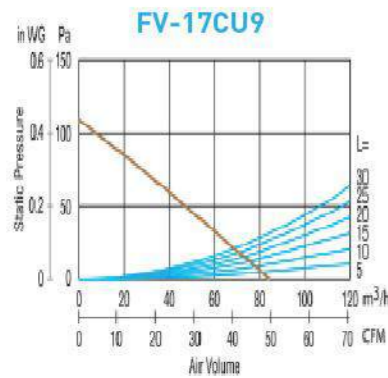

## FV-27CH9 Super Quiet Series



- High-Low speed selectable
- Condenser motor with thermal cut-off
- Well lubricated bearing for long life operation
- Pre-installed power cord
- Resonance-Noise-Absorption structure
- High performance taper blade designed sirocco fan

### Dimension

Unit: mm

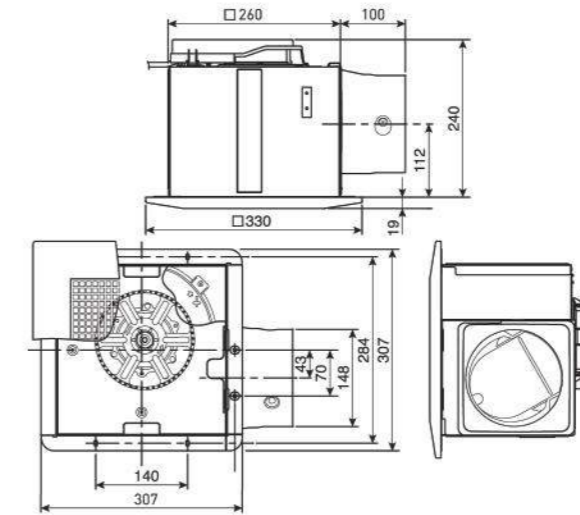

### Specification

Model No.	Hz	Consumption [W]	R.P.M [min <sup>-1</sup> ]	Air Volume		Noise [dB(A)]	Weight [kg]	Installation Space [mm]	Duct Size [mm]
				[CMH]	[CFM]				
FV-27CH9	50	28	570	330	194	34	4.4	270 x 270	Ø150
				260	153				

Note: The value in Specification table are representative characteristics value at 220V, 50Hz. R.P.M. data is for reference only, values may vary subject to different conditions.

### Performance Data

(220V 50Hz)

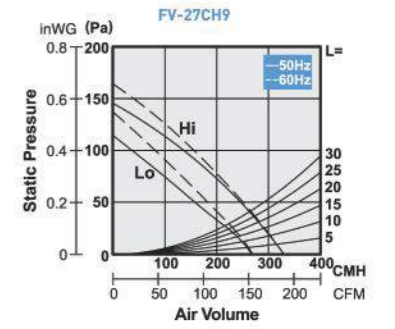

## FV-32CD9/ FV-32CH9 Super Quiet Series



- High-Low speed selectable
- Condenser motor with thermal cut-off
- Well lubricated bearing for long life operation
- Pre-installed power cord
- Resonance-Noise-Absorption structure
- High performance taper blade designed sirocco fan

### Dimension

Unit: mm

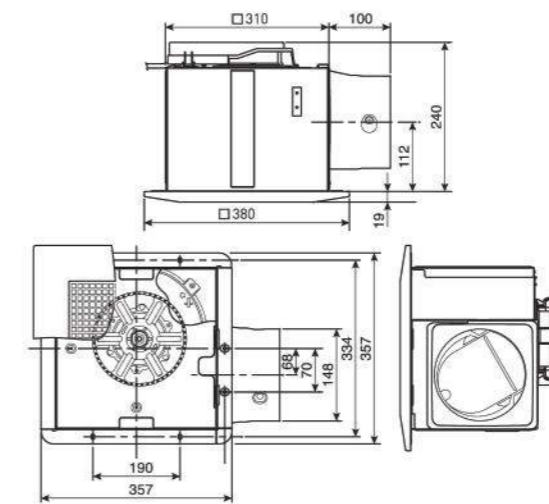

### Specification

Model No.	Hz	Consumption [W]	R.P.M [min <sup>-1</sup> ]	Air Volume		Noise [dB(A)]	Weight [kg]	Installation Space [mm]	Duct Size [mm]
				[CMH]	[CFM]				
FV-32CD9	50	42	590	430	253	36	5.2	320 x 320	Ø150
				300	177				
FV-32CH9	50	55	710	530	312	41	5.6	320 x 320	Ø150
				400	235				

Note: The value in Specification table are representative characteristics value at 220V, 50Hz. R.P.M. data is for reference only, values may vary subject to different conditions.

### Performance Data

(220V 50Hz)

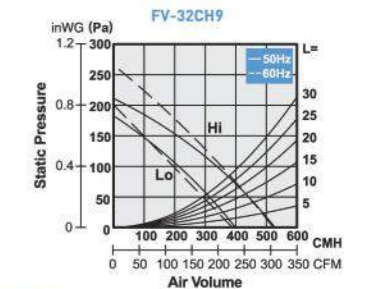
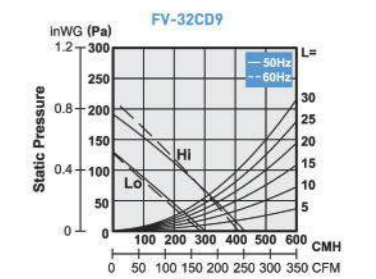

## FV-38CD8/ FV-38CH8 Standard Series



- High-Low speed selectable
- Condenser motor with thermal cut-off
- Well lubricated bearing for long life operation
- High performance sirocco fan

### Dimension

Unit: mm

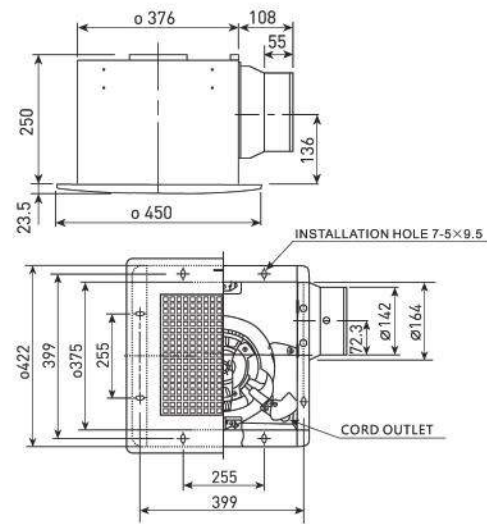

### Performance Data

(220V 50Hz)

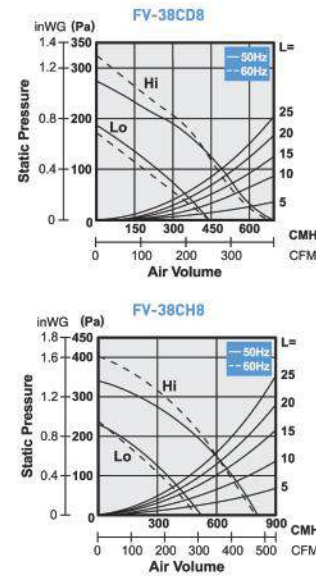

### Specification

Model No.	Hz	Consumption [W]	R.P.M [min <sup>-1</sup> ]	Air Volume		Noise [dB(A)]	Weight [kg]	Installation Space [mm]	Duct Size [mm]
				[CMH]	[CFM]				
FV-38CD8	Hi	90	645	640	640	44	9.7	385 x 385	Ø150
	Lo	66	456	430	430	35			
FV-38CH8	Hi	122	790	800	800	49	10.4	385 x 385	Ø150
	Lo	89	540	525	525	39			

Note: The value in Specification table are representative characteristics value at 220V, 50Hz. R.P.M. data is for reference only, values may vary subject to different conditions.

## FV-20CUT1/ FV-15TGU1/ FV-25TGU5 Propeller Series



- High air volume
- Easy installation
- Designed for a long service life with continuous daily operation
- Motor equipped with thermal fuse

### Dimension

Unit: mm

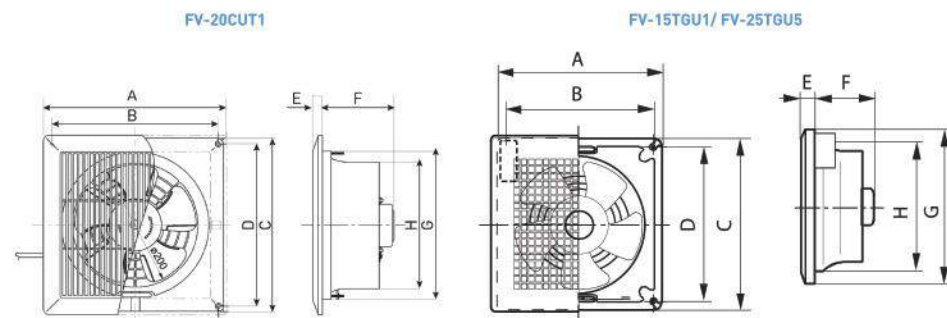

Model No.	A	B	C	D	E	F	G	H
FV-24CU8	315	286	305	286	18	128	260	223
FV-24CD8	244	224.5	244	224.5	18	108.1	252.5	214
FV-24CH8	355	336	355	336	31	107.5	362.5	310

### Specification

Model No.	Hz	Consumption [W]	R.P.M [min <sup>-1</sup> ]	Air Volume		Noise [dB(A)]	Weight [kg]	Installation Space [mm]
				[CMH]	[CFM]			
FV-20CUT1	50	22.6	1,153	438	258	40.5	1.8	270 x 270
FV-15TGU1	50	10	1330	240	141	35	1.2	220 x 220
FV-25TGU5	50	26.5	970	612	360	39	1.4	320 x 320

Note: The value in Specification table are representative characteristics value at 220V, 50Hz. R.P.M. data is for reference only, values may vary subject to different conditions.

## LOW NOISE TYPE CABINET FAN (In-Line Fan)

### High Performance

- The newly developed twin flow fan achieves large air volume and high static pressure.
- The tapered scroll at fan case can minimize the turbulence induced by uneven wind velocity inside the casing.

### Low Noise

- Noise absorption material adopted for reduction of noise level.

### Easy Installation

- Exclusive U-type grooved hanging brackets provide safety installation.
- Able to install upside down for different location of inspection panel.

### Easy Maintenance

- Detachable inspection panel can be removed easily for maintenance.

### Reliability

- Long life condenser motor with thermal cut-off is adopted.

### Flexibility

- 2-speed selectable enhances flexibility for various usages (for single phase models only).

### Compact Size

- Slim and compact design allows installation at narrow ceiling space.

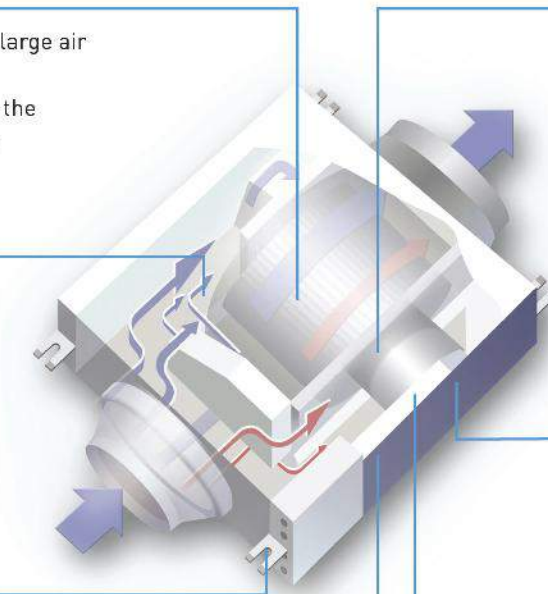

### Twin Flow Fan

The newly developed twin flow fan achieves a better airflow inside the fan casing. It is divided into two portions which can generate large air volume and high static pressure respectively.

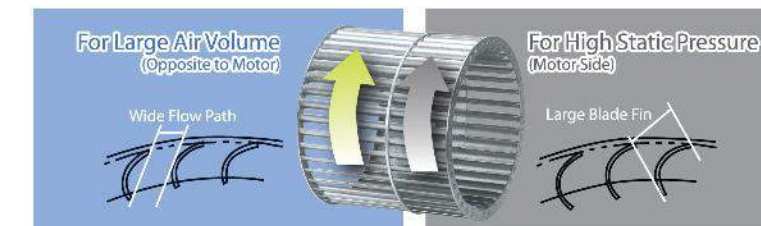

### Embedded Terminal Box

Terminal boxes of new models are embedded into the product frame. Wiring to power supply is covered with metal enclosure that enhances the durability and safety concern.

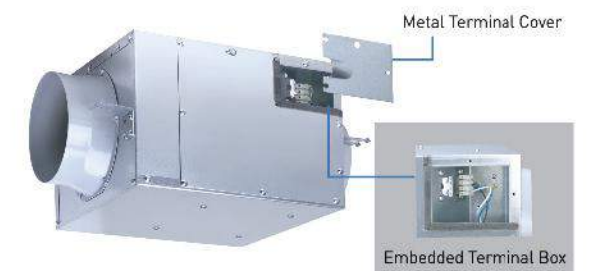

### Tapered Scroll

Wind velocity varies according to the shape of fan casing. The tapered scroll at the fan casing can minimize the turbulence induced by uneven wind velocity inside the casing.

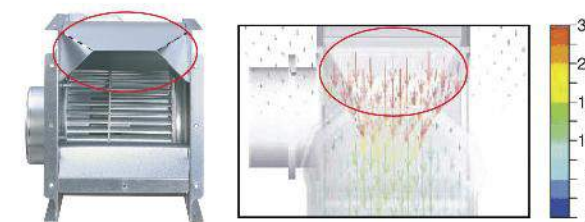

Internal Wind Velocity Distribution - Airflow Analysis

## FV-12NS3/ FV-15NS3 Single Phase Series



- Long life condenser motor with thermal cut-off
- Twin flow fan (sirocco fan)
- Fan casing with tapered scroll
- Embedded terminal box
- Noise absorption material adopted
- Compact size

### Dimension

Unit: mm

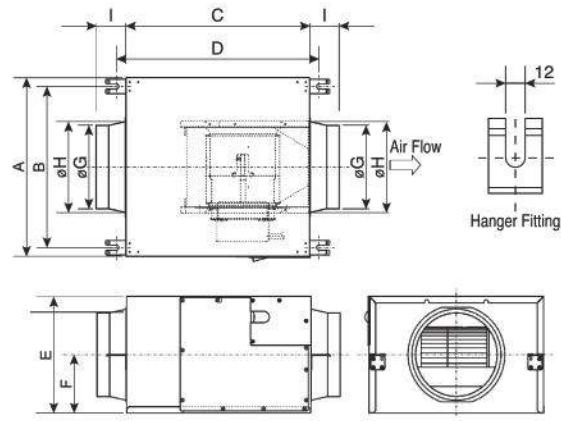

Model No.	A	B	C	D	E	F	G	H	I
FV-12NS3	290	250	291	335	184	92	97	112	51
FV-15NS3	290	250	302	346	206	103	146	163	60

### Specification

Model No.	Phase	Hz	*	Consumption [W]	R.P.M [min <sup>-1</sup> ]	Air Volume		Noise [dB(A)]	Weight [kg]	Impeller Diameter [mm]	Duct Size [mm]
						[CMH]	[CFM]				
FV-12NS3	1	50		18	1,265	180	106	21	5.5	128	Ø100
						Lo	17	1,020			
FV-15NS3	1	50		33	1,270	340	200	25	6.5	128	Ø150
						Lo	29.5	1,100			

Note: The value in Specification table are representative characteristics value at 220V, 50Hz. R.P.M. data is for reference only, values may vary subject to different conditions.

### Performance Data

(220V 50Hz)

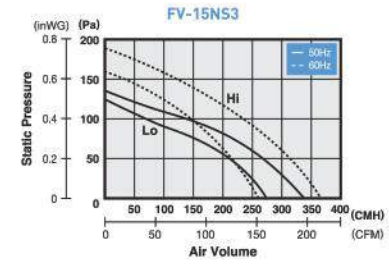
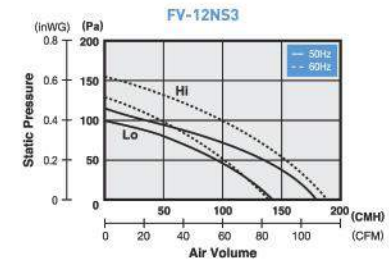

## FV-20NS3/ FV-23NL3 Single Phase Series



- Long life condenser motor with thermal cut-off
- Twin flow fan (sirocco fan)
- Fan casing with tapered scroll
- Embedded terminal box
- Noise absorption material adopted
- Compact size

### Dimension

Unit: mm

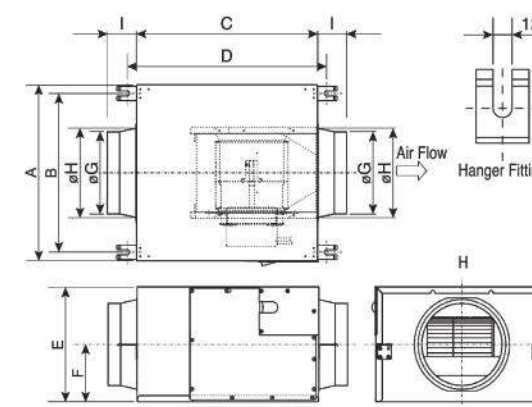

Model No.	A	B	C	D	E	F	G	H	I
FV-20NS3	416	376	441	485	272	136	195	211	70
FV-23NL3	468	424	469	513	298	149	195	211	70

### Specification

Model No.	Phase	Hz	*	Consumption [W]	R.P.M [min <sup>-1</sup> ]	Air Volume		Noise [dB(A)]	Weight [kg]	Impeller Diameter [mm]	Duct Size [mm]
						[CMH]	[CFM]				
FV-20NS3	1	50		120	1,195	920	541	32	14	178	Ø 200
						Lo	113	1,000			
FV-23NL3	1	50		230	1,245	1,200	706	40	18	220	Ø 200
						Lo	170	985			

Note: The value in Specification table are representative characteristics value at 220V, 50Hz. R.P.M. data is for reference only, values may vary subject to different conditions.

### Performance Data

(220V 50Hz)

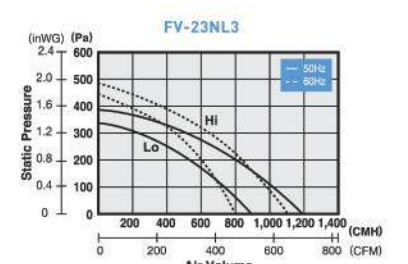
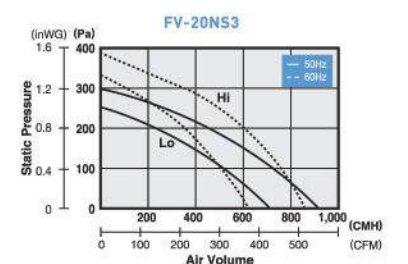

## FV-18NS3/ FV-18NF3 Single Phase Series



- Long life condenser motor with thermal cut-off
- Twin flow fan (sirocco fan)
- Fan casing with tapered scroll
- Embedded terminal box
- Noise absorption material adopted
- Compact size

### Dimension

Unit: mm

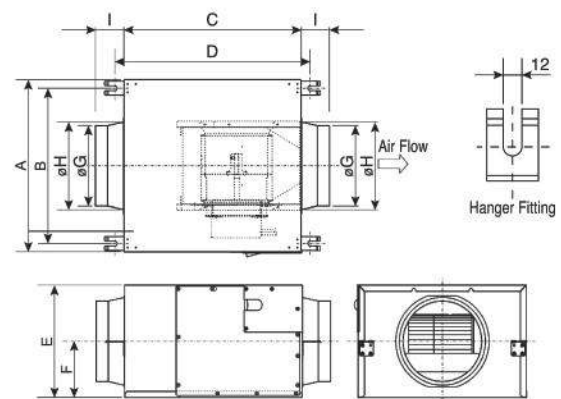

Model No.	A	B	C	D	E	F	G	H	I
FV-18NS3	316	276	338	382	232	116	145	163	60
FV-18NF3	376	336	397	441	254	127	195	211	70

### Specification

Model No.	Phase	Hz	*	Consumption [W]	R.P.M [min <sup>-1</sup> ]	Air Volume		Noise [dB(A)]	Weight [kg]	Impeller Diameter [mm]	Duct Size [mm]
						[CMH]	[CFM]				
FV-18NS3	1	50		60	1,250	500	294	29	8.5	158	Ø150
						Lo	55	1,100			
FV-18NF3	1	50		91	1,190	770	453	31	10	158	Ø200
						Lo	80	1,000			

Note: The value in Specification table are representative characteristics value at 220V, 50Hz. R.P.M. data is for reference only, values may vary subject to different conditions.

### Performance Data

(220V 50Hz)

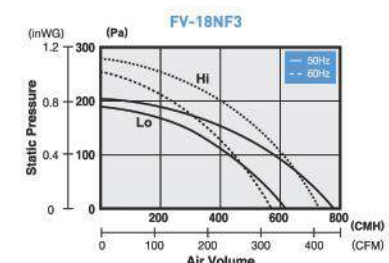
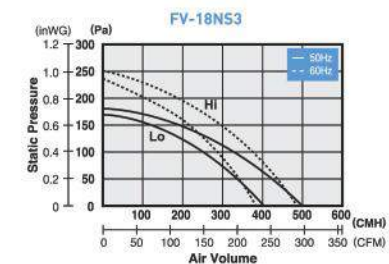

## FV-25NS3/ FV-25NF3 Single Phase Series



- Long life condenser motor with thermal cut-off
- Twin flow fan (sirocco fan)
- Fan casing with tapered scroll
- Embedded terminal box
- Noise absorption material adopted
- Compact size

### Dimension

Unit: mm

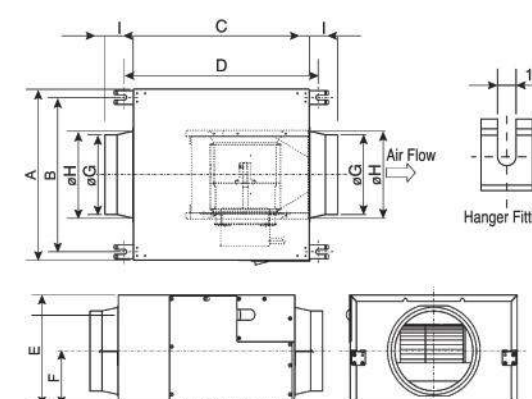

Model No.	A	B	C	D	E	F	G	H	I
FV-25NS3	494	450	505	549	334	167	240	255	85
FV-25NF3	494	450	505	549	334	167	240	255	85

### Specification

Model No.	Phase	Hz	*	Consumption [W]	R.P.M [min <sup>-1</sup> ]	Air Volume		Noise [dB(A)]	Weight [kg]	Impeller Diameter [mm]	Duct Size [mm]
						[CMH]	[CFM]				
FV-25NS3	1	50		345	1,125	1,700	1,001	41	24	220	Ø 250
						Lo	265	950			
FV-25NF3	1	50		390	1,225	1,900	1,118	43	24	220	Ø 250
						Lo	325	1,070			

Note: The value in Specification table are representative characteristics value at 220V, 50Hz. R.P.M. data is for reference only, values may vary subject to different conditions.

### Performance Data

(220V 50Hz)

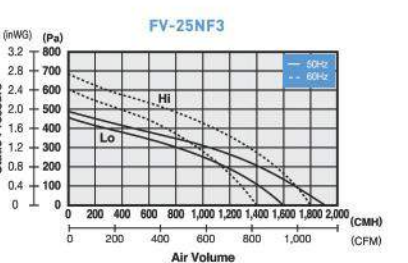
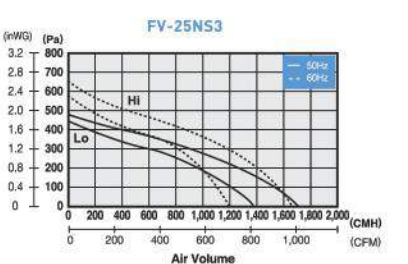

## FV-25SW3 / FV-25SM3 Three Phase Series



Dimension  
Unit: mm

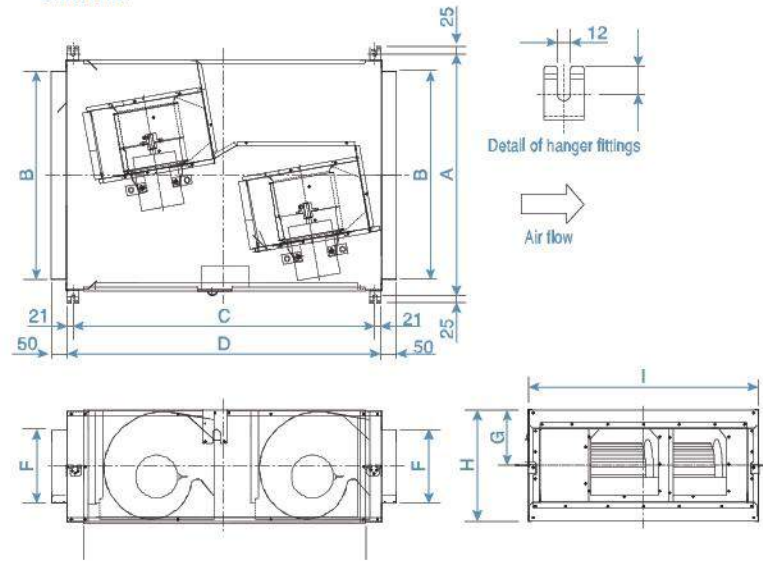

- Long life condenser motor with thermal cut-off
- Twin flow fan (sirocco fan)
- Fan Casing with tapered scroll
- Embedded terminal box
- Noise absorption material adopted
- Compact size

## FV-28NX3 Three Phase Series



Dimension  
Unit: mm

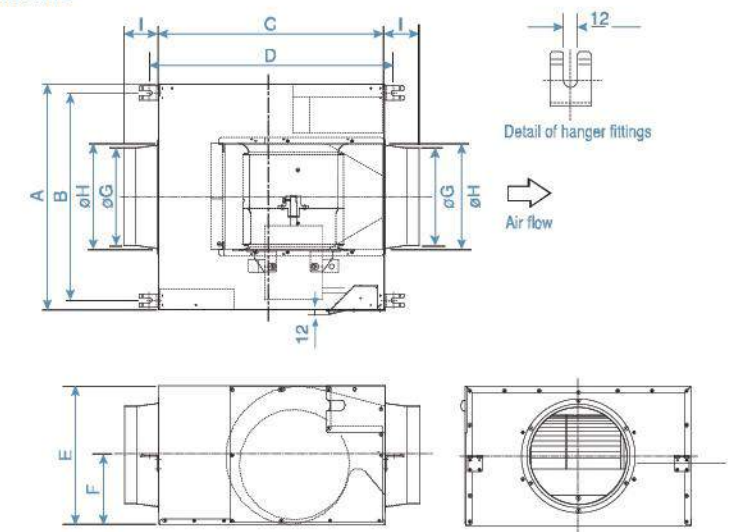

- Long life condenser motor with thermal cut-off
- Twin flow fan (sirocco fan)
- Fan Casing with tapered scroll
- Embedded terminal box
- Noise absorption material adopted
- Compact size

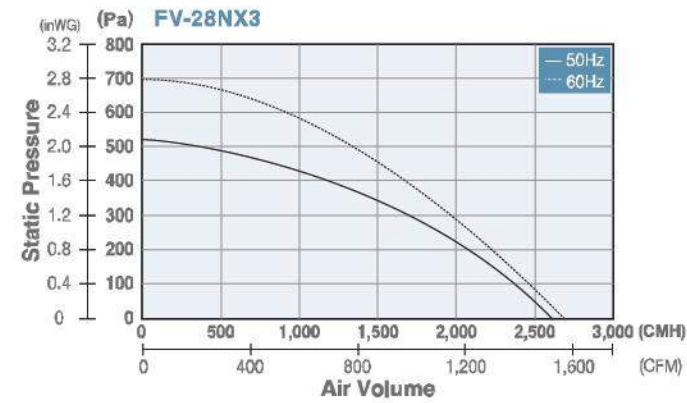
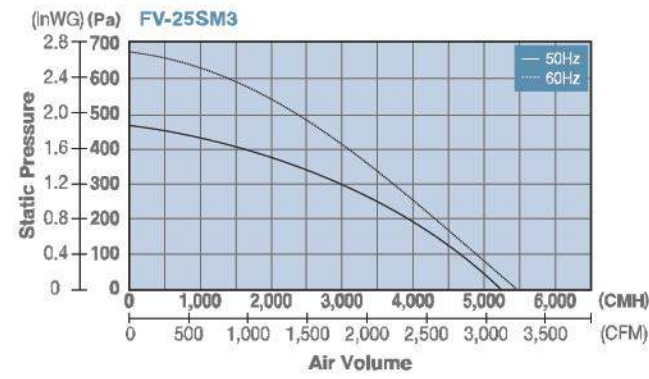
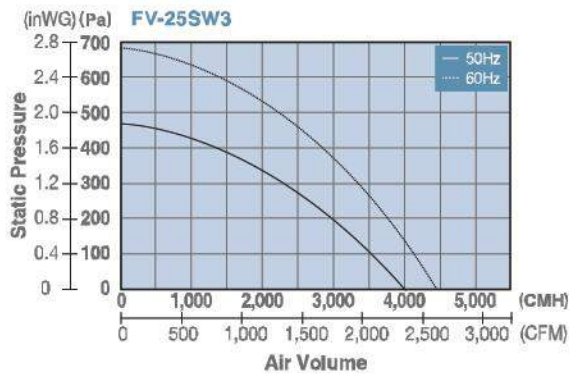

Model No.	A	B	C	D	E	F	G	H	I
FV-25SW3	809	496	1,010	1,052	942	246	185	370	766
FV-25SM3	809	696	1,010	1,052	942	246	185	370	766

Model No.	A	B	C	D	E	F	G	H	I
FV-28NX3	554	510	557	601	342	171	240	255	85

### Specification

Model No.	Phase	Hz	Consumption [W]	R.P.M. [min <sup>-1</sup> ]	Air Volume		Noise [dB(A)]	Weight [kg]	Duct Size [mm]	Impeller Diameter [mm]
					[CMH]	[CFM]				
FV-25SW3	3	50	940	1,375	4,000	2,354	43	60	250 X 500	250
		60	1,450	1,530	4,500	2,649	45			
FV-25SM3	3	50	1,180	1,345	5,200	3,061	45	60	250 X 700	250
		60	1,750	1,470	5,500	3,237	46			

Note: The value in Specification tables are representative characteristic value at 380V, 50/60Hz. R.P.M. data is for reference only, values may vary subject to different conditions.

### Specification

Model No.	Phase	Hz	Consumption [W]	R.P.M. [min <sup>-1</sup> ]	Air Volume		Noise [dB(A)]	Weight [kg]	Duct Size [mm]	Impeller Diameter [mm]
					[CMH]	[CFM]				
FV-28NX3	3	50	600	1,295	2,600	1,530	44	28	Ø250	280
		60	840	1,380	2,650	1,560	45			

Note: The value in Specification tables are representative characteristic value at 380V, 50/60Hz. R.P.M. data is for reference only, values may vary subject to different conditions.



# INDUSTRIAL TYPE VENTILATING FAN

## Features of High Pressure Series

### 1 High Static Pressure, Low Power Consumption

The unique design of wave-shaped blade and bellmouth construction enable better performance in high static pressure and low power consumption.

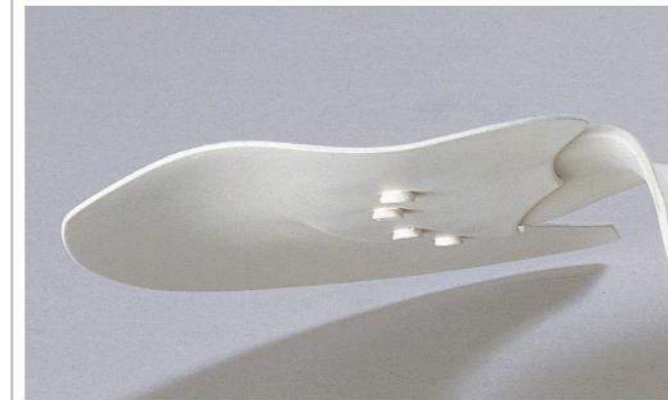

Fans with 3-dimensional wave-shaped cross section blade

### 2 Low Noise Design

The blade's distinctive wave-shaped is developed by application of hydrodynamic analysis. It can deliver a smooth and turbulence free airflow, meaning the performance in big air volume but with less noise.

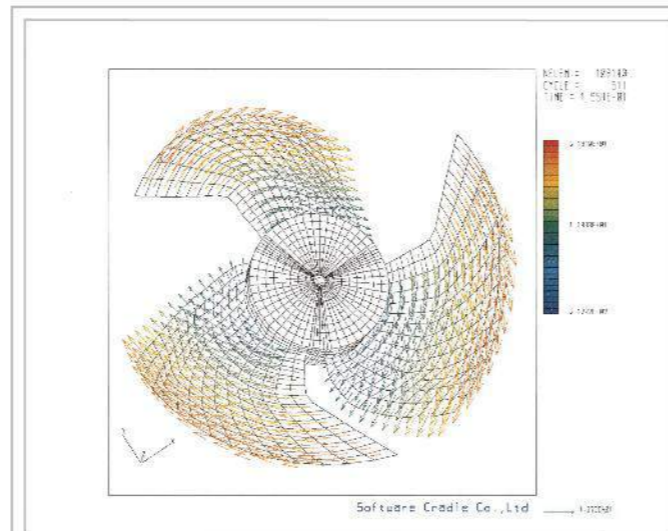

Surface Velocity Vector Diagram

Pressure is distributed more uniformly over the surface of the blade, making it more durable. A special polyester resin powder coating give a beautiful color and a highly rust-resistant finishing.

### 3 Improved Durability

## FV-25GS4/ FV-30GS4 High Pressure Series



Dimension Unit: mm

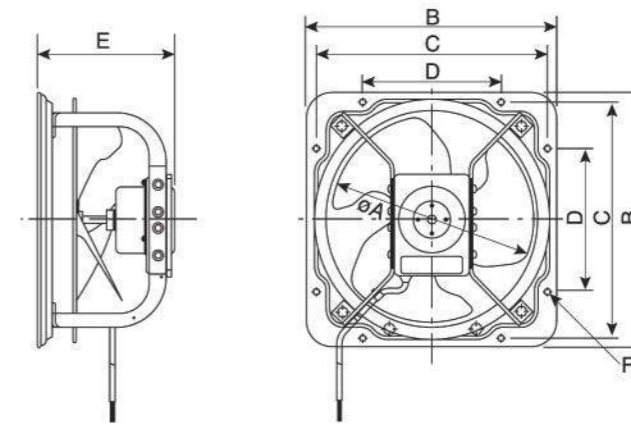

Model No.	A	B	C	D	E	F
FV-25GS4	250	327	298	165	171	10
FV-30GS4	300	378	349	210	200	10

### Specification

Model No.	Hz	Consumption [W]	R.P.M. [min <sup>-1</sup> ]	Air Volume		Noise [dB(A)]	Weight [kg]
				[CMH]	[CFM]		
FV-25GS4	50	39	1,360	1100	647	34	4.4
FV-30GS4	50	59	1,360	1800	1059	38	6.1

Note: The value in Specification table are representative characteristics value at 220V, 50Hz. R.P.M. data is for reference only, values may vary subject to different conditions.

### Performance Data [220V 50Hz]

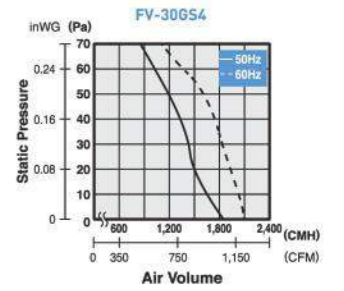
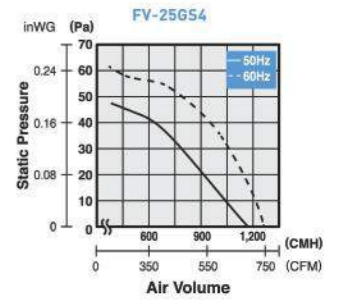

## FV-35GS4 High Pressure Series



Dimension Unit: mm

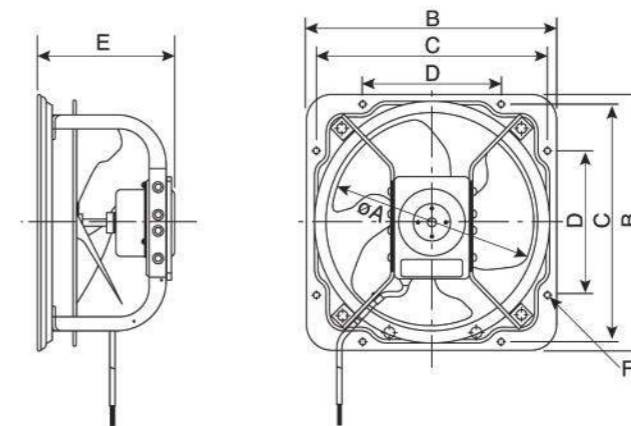

Model No.	A	B	C	D	E	F
FV-35GS4	350	467	434	250	236	12

### Specification

Model No.	Hz	Consumption [W]	R.P.M. [min <sup>-1</sup> ]	Air Volume		Noise [dB(A)]	Weight [kg]
				[CMH]	[CFM]		
FV-35GS4	50	88	1,420	2670	1571	44	10.5

Note: The value in Specification table are representative characteristics value at 220V, 50Hz. R.P.M. data is for reference only, values may vary subject to different conditions.

### Performance Data [220V 50Hz]

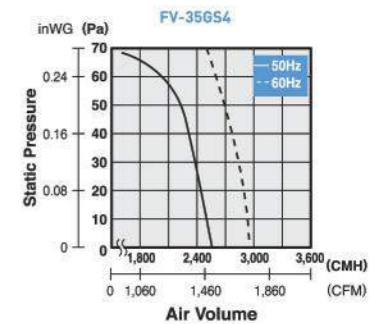

## FV-40GS4/ 45GS4 High Pressure Series



### Dimension Unit: mm

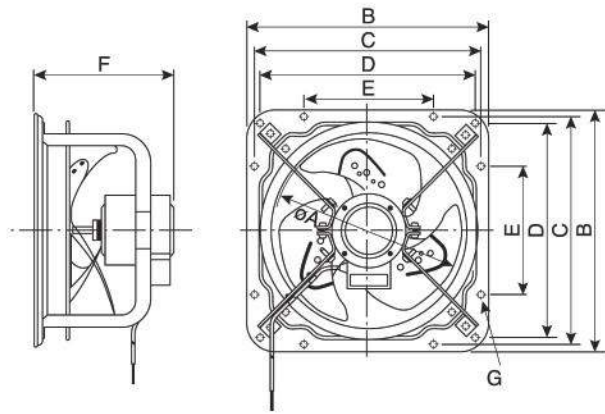

Model No.	A	B	C	D	E	F	G
FV-40GS4	400	518	485	460	280	274	12
FV-45GS4	450	570	540	460	320	297	12

### Specification

Model No.	Hz	Consumption [W]	R.P.M. [min <sup>-1</sup> ]	Air Volume		Noise [dB(A)]	Weight [kg]
				[CMH]	[CFM]		
FV-40GS4	50	161	1,450	3780	2224	47	19
FV-45GS4	50	277	1,410	5400	3176	51	19

Note: The value in Specification table are representative characteristics value at 220V, 50Hz. R.P.M. data is for reference only, values may vary subject to different conditions.

- Single Phase
- Reversible by adjusting wiring and blade
- Bellmouth construction with distinctive wave-shaped blade
- Durable powder coating
- High performance motor with thermal cut-off
- Able to be used over an ambient temperature range from -10°C to +50°C
- Possible to install horizontally or vertically
- Optional guard and shutter available

### Performance Data (220V 50Hz)

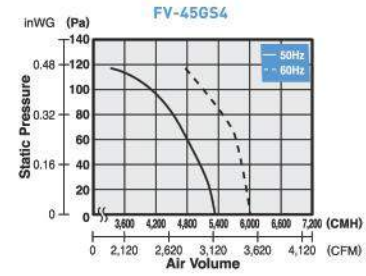
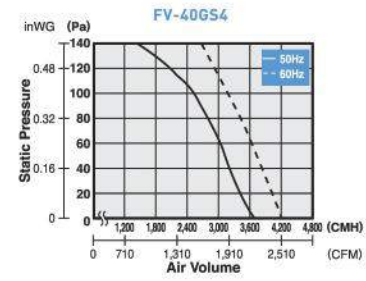

## FV-50GS4/ 60GS4 High Pressure Series



### Dimension Unit: mm

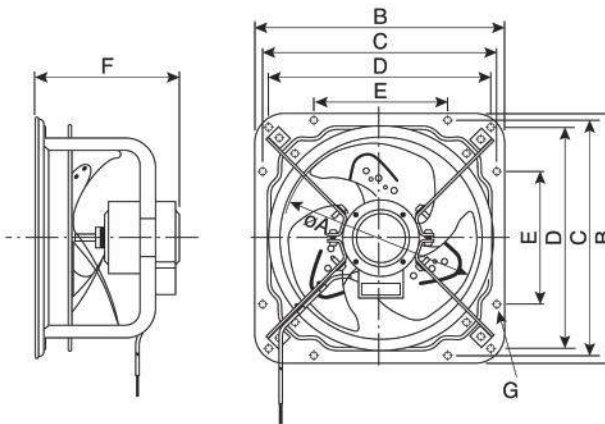

Model No.	A	B	C	D	E	F	G
FV-50GS4	500	659	620	560	355	315	15
FV-60GS4	620	760	720	650	400	320	15

### Specification

Model No.	Hz	Consumption [W]	R.P.M. [min <sup>-1</sup> ]	Air Volume		Noise [dB(A)]	Weight [kg]
				[CMH]	[CFM]		
FV-50GS4	50	249	960	6,130	3,608	47	22.5
FV-60GS4	50	245	970	8,040	4,732	50	34

Note: The value in Specification table are representative characteristics value at 220V, 50Hz. R.P.M. data is for reference only, values may vary subject to different conditions.

- Single Phase
- Reversible by adjusting wiring and blade
- Bellmouth construction with distinctive wave-shaped blade
- Durable powder coating
- High performance motor with thermal cut-off
- Able to be used over an ambient temperature range from -10°C to +50°C
- Possible to install horizontally or vertically
- Optional guard and shutter available

### Performance Data (220V 50Hz)

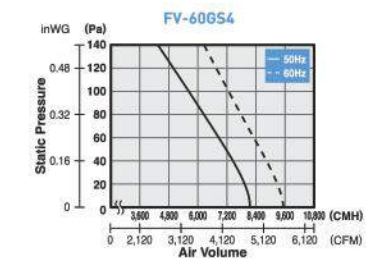
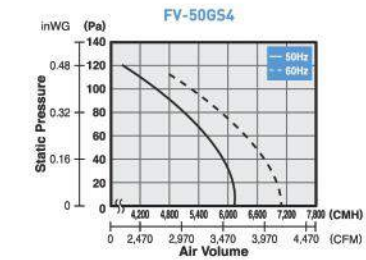

## FV-45GT4/ FV-50GT4/ FV-60GT4 High Pressure Series



### Dimension Unit: mm

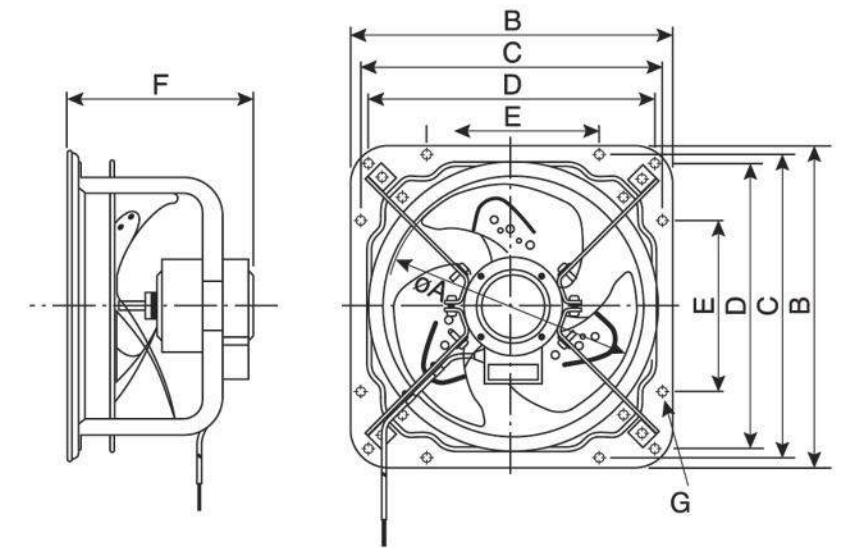

Model No.	A	B	C	D	E	F	G
FV-45GT4	450	570	540	-	320	297	12
FV-50GT4	500	659	620	560	355	304	15
FV-60GT4	620	760	720	650	400	320	15

### Specification

Model No.	Hz	Consumption [W]	R.P.M. [min <sup>-1</sup> ]	Air Volume		Noise [dB(A)]	Weight [kg]
				[CMH]	[CFM]		
FV-45GT4	50	220	1,450	5,520	3,249	52	18.5
FV-50GT4	50	320	1,400	6,960	4,097	54	28.5
FV-60GT4	50	310	940	9,420	5,544	49	34

Note: The value in Specification table are representative characteristics value at 220V, 50Hz. R.P.M. data is for reference only, values may vary subject to different conditions.

- Three Phase
- Reversible by adjusting wiring and blade
- Bellmouth construction with distinctive wave-shaped blade
- Durable powder coating
- High performance motor with thermal cut-off
- Able to be used over an ambient temperature range from -10°C to +50°C
- Possible to install horizontally or vertically
- Optional guard and shutter available

### Performance Data (220V 50Hz)

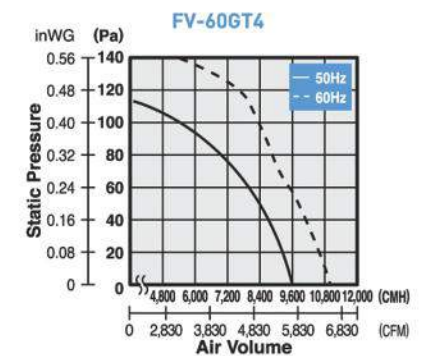
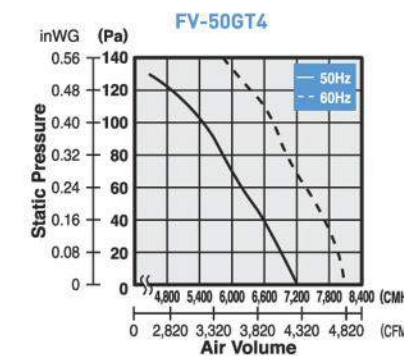
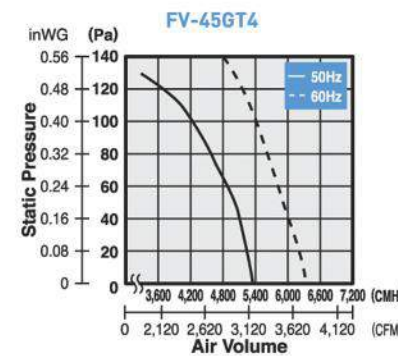





# WALL MOUNT TYPE VENTILATING FAN

## General Features



### Advanced Blade Design

New blade design applies advanced aerodynamic principle that minimizes any obstacles against the airflow.

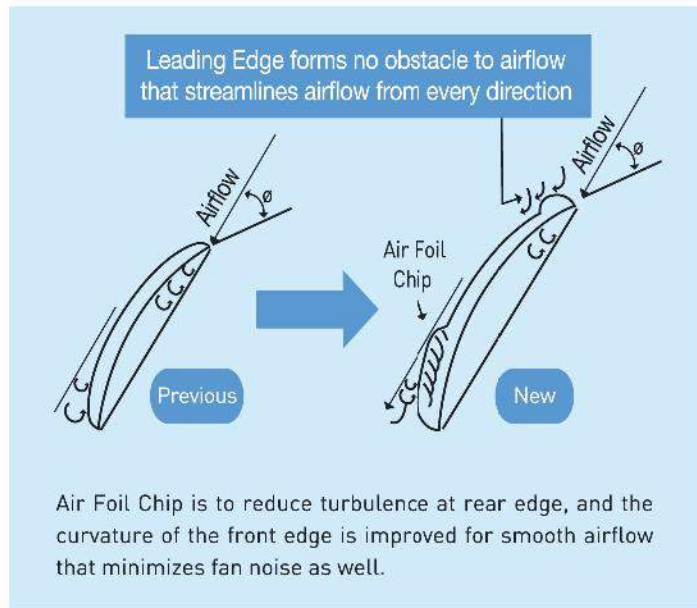

### HP (Half-Pitch) Motor & Bearing

Compared with previous models, new models adopt high performance condenser motor and long life bearing that prolong the product durability, from average 30,000 hours life time to 60,000 hours.

They also enable energy saving by reducing power consumption down to average 13%.

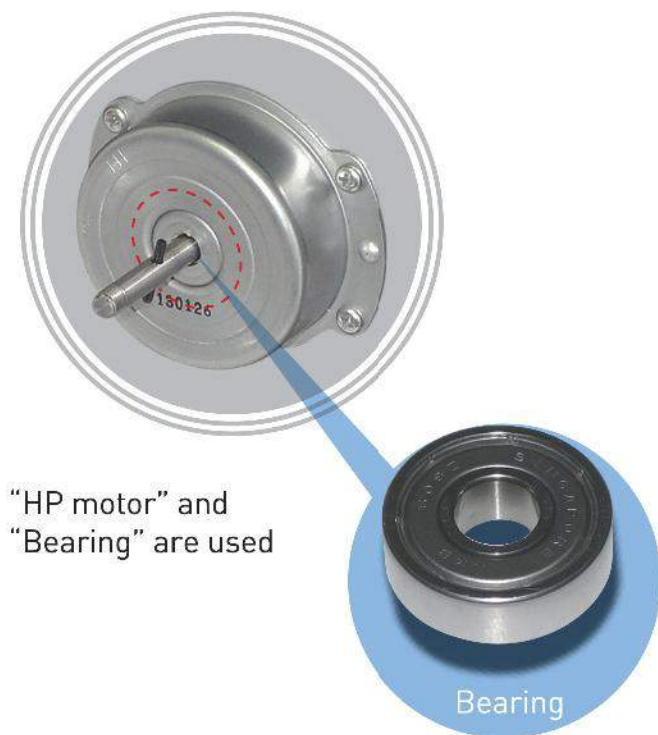

"HP motor" and "Bearing" are used

Bearing

## FV-10EGS1/ FV-15EGS1 Bathroom Series



- Shutter Series (for Vertical Shaft)
- Powerful exhaust of moisture and smell
- Compact and stylish design
- Back draft shutter
- All accessories are included for most convenience
- Easy installation

Dimension  
Unit: mm

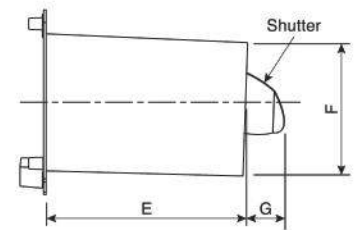
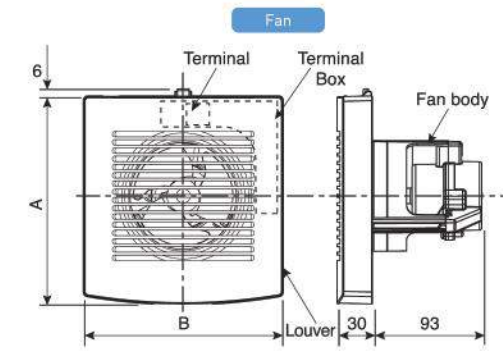

Model No.	A	B	C	D	E	F	G
FV-10EGS1	176	170	9.3	177	160	115	40
FV-15EGS1	230	220	11.5	230	160	160	80

### Specification

Model No.	Hz	Consumption [W]	R.P.M. [min <sup>-1</sup> ]	Air Volume		Noise	Weight [kg]	Installation Space [mm]
				[CMH]	[CFM]			
FV-10EGS1	50	5.5	2,706	75	44	33	0.9	Ø120 - Ø125
FV-15EGS1	50	6.2	2,329	150	88	36	1.1	Ø165 - Ø170

Note: The value in Specification table are representative characteristics value at 220V, 50Hz. R.P.M. data is for reference only, values may vary subject to different conditions. This specifications are specified with duct sleeve, duct spinner and pipe hood.

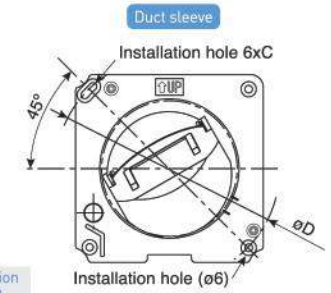

## FV-10EGF1/ FV-15EGF1 Bathroom Series



- Very low noise
- Insect screening net equipped
- Slim design (Outside hood)
- Water resistance for safe operation

Dimension  
Unit: mm

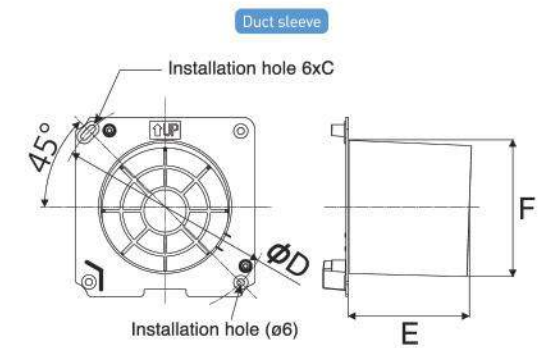
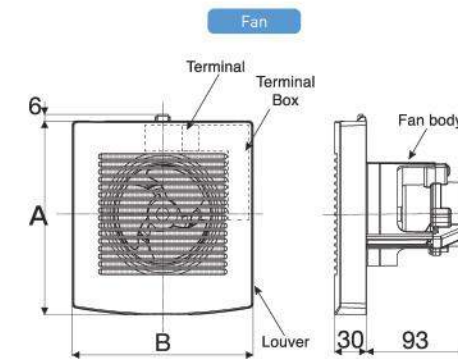

Model No.	A	B	C	D	E	F
FV-10EGF1	176	170	9.3	177	100	113
FV-15EGF1	230	220	12	230	100	158

### Specification

Model No.	Hz	Consumption [W]	R.P.M. [min <sup>-1</sup> ]	Air Volume		Noise	Weight [kg]	Installation Space [mm]
				[CMH]	[CFM]			
FV-10EGK1	50	5.5	2,706	75	44	31	0.9	Ø135 ± 5
FV-15EGK1	50	6.2	2,369	155	91	33	1.1	Ø180 ± 5

Note: The value in Specification table are representative characteristics value at 220V, 50Hz. R.P.M. data is for reference only, values may vary subject to different conditions. This specifications are specified with duct sleeve.

## FV-25AUF1 Filter Series



### Dimension Unit: mm

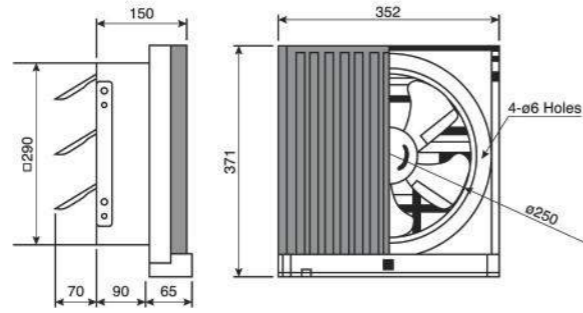

### Performance Data (220V 50Hz)

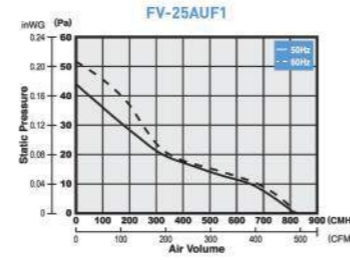

### Specification

Model No.	Hz	Consumption [W]	R.P.M. [min <sup>-1</sup> ]	Air Volume		Noise [dB(A)]	Weight [kg]	Installation Space [mm]
				[CMH]	[CFM]			
FV-25AUF1	50	34	1,100	835	491	42	2.8	300 x 300

Note: The value in Specification table are representative characteristics value at 220V, 50Hz. R.P.M. data is for reference only, values may vary subject to different conditions.

- Recommend to use in kitchen
- Automatic Shutter
- Perforated aluminum filter with hydrophobic coating
- Large capacity oil cup
- Oil Indicator on oil cup
- High exhaust air volume under actual usage condition (20Pa)

## FV-15AUL1 Automatic Shutter Series



### Dimension Unit: mm

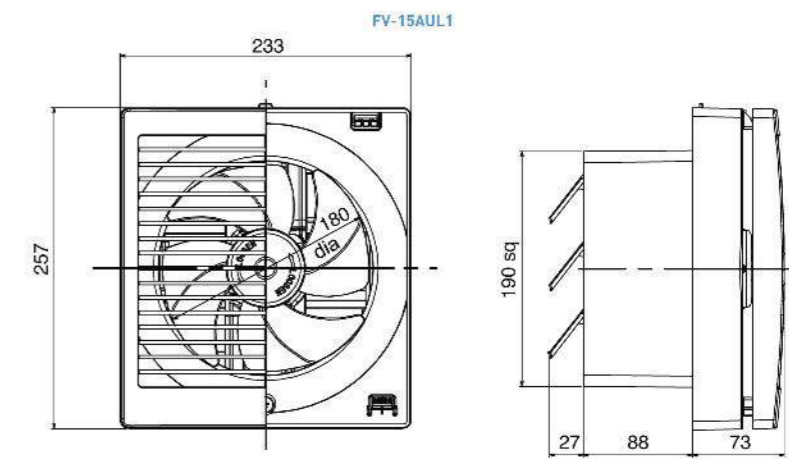

- Condenser motor with thermal cut-off
- Well lubricated ball bearing for long life operation
- Plastic frame and backcraft shutter
- Detachable front louver

### Specification

Model No.	Hz	Consumption [W]	R.P.M. [min <sup>-1</sup> ]	Air Volume		Noise [dB(A)]	Weight [kg]	Installation Space [mm]
				[CMH]	[CFM]			
FV-15AUL1	50	12.5	1,450	255	150	36	1.2	200 x 200

Note: The value in Specification table are representative characteristics value at 220V, 50Hz. R.P.M. data is for reference only, values may vary subject to different conditions.

## FV-20AU1/FV-25AU1/FV-30AU1 Automatic Shutter Series



### Dimension Unit: mm

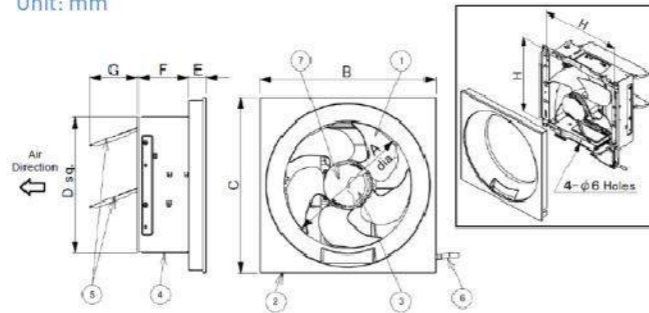

Model No.	A	B	C	D	E	F	G	H
FV-20AU1	223	310	310	240	30	90	85	260
FV-25AU1	273	360	360	290	32	90	67	310
FV-30AU1	317	410	410	340	32	90	83	360

### Specification

Model No.	Hz	Consumption [W]	R.P.M. [min <sup>-1</sup> ]	Air Volume		Noise [dB(A)]	Weight [kg]	Installation Space [mm]
				[CMH]	[CFM]			
FV-20AU1	50	18	1250	590	590	36	1.9	250x250
FV-25AU1	50	25	1200	950	950	38	2.3	300x300
FV-30AU1	50	28	880	1200	1200	37	2.6	350x350

Note  
\*The value of power consumption, air volume and noise are specified at static pressure of 0 Pa.  
\*The value of noise level is measured at 1m apart from the left, the right and the directly below of product, then get the average of three values.

- Low Noise by Silent Stream Fan
- Long Life Ball Bearing Motor with thermal cut-off
- Steel Frame and Shutter
- Motor Insulation Class: B
- Cut-off safety switch equipped
- Water Resistance: IPX4 (Outside)

## FV-20AL1/FV-25AL1/FV-30AL1 Automatic Shutter Series



### Dimension Unit: mm

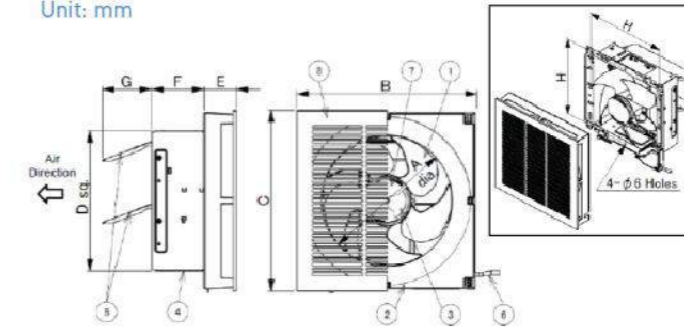

Model No.	A	B	C	D	E	F	G	H
FV-20AL1	223	310	310	240	56	90	85	260
FV-25AL1	273	360	360	290	58	90	67	310
FV-30AL1	317	410	410	340	58	90	83	360

### Specification

Model No.	Hz	Consumption [W]	R.P.M. [min <sup>-1</sup> ]	Air Volume		Noise [dB(A)]	Weight [kg]	Installation Space [mm]
				[CMH]	[CFM]			
FV-20AL1	50	18	1250	550	550	38.0	12.09	250x250
FV-25AL1	50	25	1160	840	840	40.5	2.5	300x300
FV-30AL1	50	28	840	1000	1000	39.0	2.8	350x350

Note  
\*The value of power consumption, air volume and noise are specified at static pressure of 0 Pa.  
\*The value of noise level is measured at 1m apart from the left, the right and the directly below of product, then get the average of three values.

- Low Noise by Silent Stream Fan
- Long Life Ball Bearing Motor with thermal cut-off
- Steel Frame and Shutter
- Motor Insulation Class: B
- Water Resistance: IPX4 (Outside)



- Low Noise by Silent Stream Fan
- Long Life Ball Bearing Motor with thermal cut-off
- Steel Frame and Shutter
- Motor Insulation Class: B
- Water Resistance: IPX4 (Outside)
- Operation by pull cord

Dimension  
Unit: mm

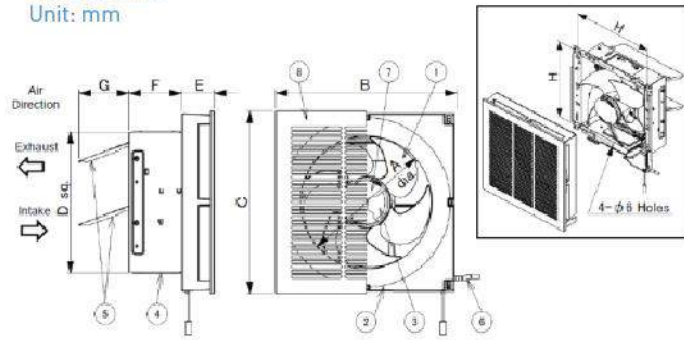

Model No.	A	B	C	D	E	F	G	H
FV-20RL1	223	310	310	240	56	90	85	260
FV-25RL1	273	360	360	290	58	90	67	310
FV-30RL1	317	410	410	340	58	90	83	360

Specification

Model No.		Hz	Consumption [W]	R.P.M [min <sup>-1</sup> ]	Air Volume		Noise [dB(A)]	Weight [kg]	Installation Space [mm]
					[CMH]	[CFM]			
FV-20RL1	Exhaust	50	17.0	1240	550	550	38.0	2.1	250x250
	Intake	50	12.0	1150	430	430	45.0		
FV-25RL1	Exhaust	50	25.0	1180	840	840	40.5	2.5	300x300
	Intake	50	16.5	1000	600	600	43.0		
FV-30RL1	Exhaust	50	27.5	860	1000	1000	39.0	2.8	350x350
	Intake	50	18.0	800	750	750	42.0		

**Note**  
 -The value of power consumption, air volume and noise are mentioned "Exhaust / Supply".  
 -The value of power consumption, air volume and noise are specified at static pressure of 0 Pa.  
 -The value of noise level is measured at 1m apart from the left, the right and the directly below of product, then get the average of three values.



BATHROOM DRYER

Adjustable Air Direction

You may select 'Spot' or 'Wide' and air direction by adjusting the air grilles during installation.

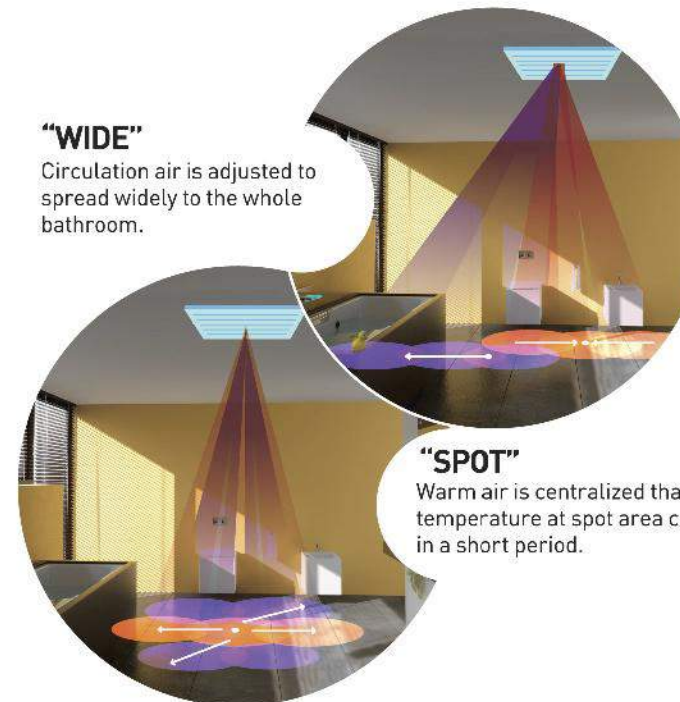

**"WIDE"**  
 Circulation air is adjusted to spread widely to the whole bathroom.

**"SPOT"**  
 Warm air is centralized that desired temperature at spot area can reach in a short period.

Both left and right grilles have 20~30° against vertical. It can be installed at 4 directions.

- Heating**  
 With PTC (Positive Temperature Coefficient) heater, Panasonic Thermo Ventilator can warm your bathroom instantly and provide a comfortable bathing experience for you.
- Clothes Drying**  
 Just simply hang your clothes under the Thermo Ventilator and switch it on, circulated airflow will dry your clothes thoroughly.
- Ventilation**  
 The Panasonic Thermo Ventilator can exhaust uncomfortable odor from the bathroom effectively. It can also restrict the growth of mold, mildew and mite by continued operation of ventilation function.
- Circulation**  
 With low noise design, Panasonic Thermo Ventilator can act as an electric fan and let you feel cool in summer.

Multi Level Safety Protection

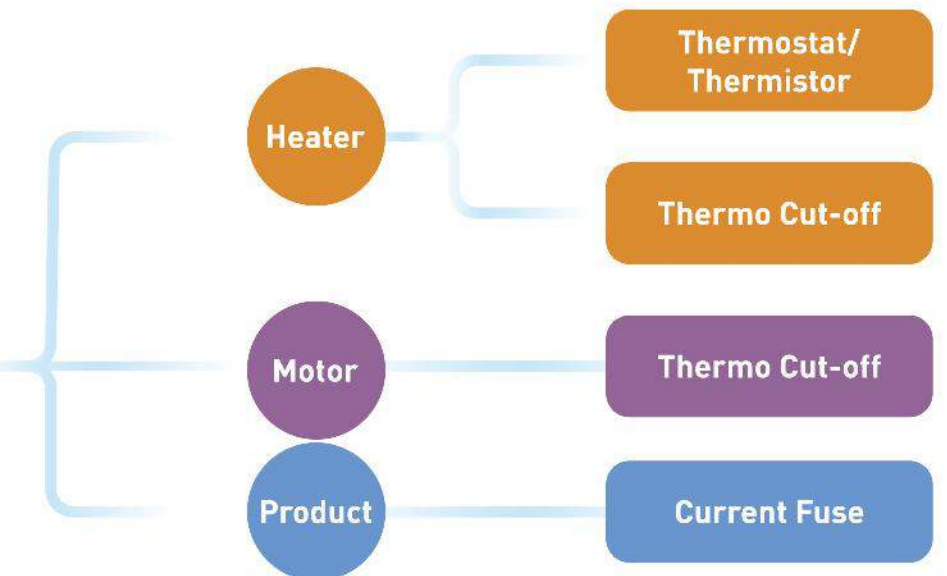



- Multifunction
- Multi Level Safety Protection
- Ceiling Mount Installation
- Air Direction (Auto Swing / Manual)
- Allergo-buster Filter
- Wireless Remote Control
- Off Timer function

Dimension  
Unit: mm

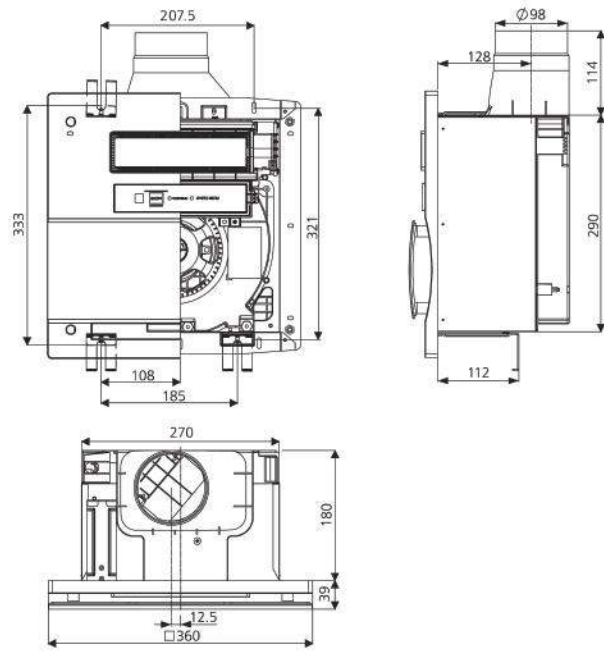

Specification

Model No.	Hz	Power Consumption [W]	Air Volume		Current [A]	Noise [dB(A)]	Weight [kg]	Installation Space [mm]	Duct Size [mm]
			[CMH]	[CFM]					
FV-30BG3	Ventilating	28	170	100	13	39	5	300 x 300	Ø 100
	Heating	1500	170	100	46				

AIR CURTAIN



Effects of Air Curtain

Doors of a shop need to be opened frequently to let people pass through. However, opening door allows air leaks to outside that increases energy consumption of air conditioning. By using Air Curtain, an invisible air screen will build up to minimize air exchange between the air outdoor and indoor.

Features highlight

Effective Barrier Effect

- Cross Flow Fan is adopted that airflow distribution is more even within the air stream while the air volume output can be maintained with low noise level.
- Unique Auxiliary Air Inlet allows more air intake at lower front that enhances airflow output.

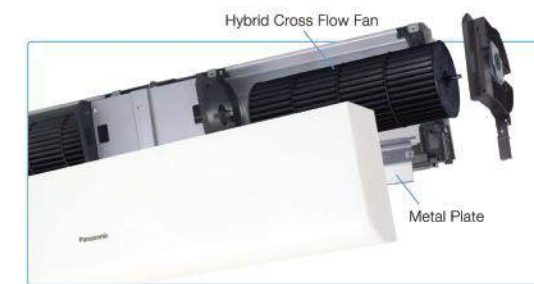

WIDE & UNIFORM AIRFLOW

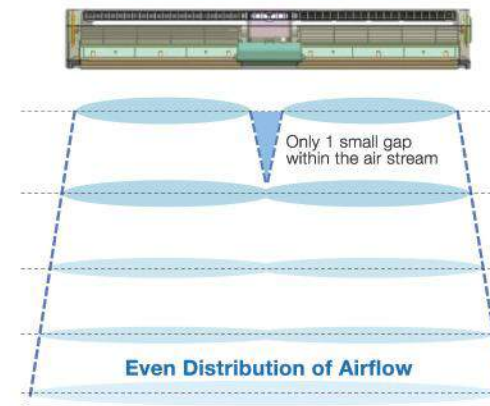

THICK AIR STREAM

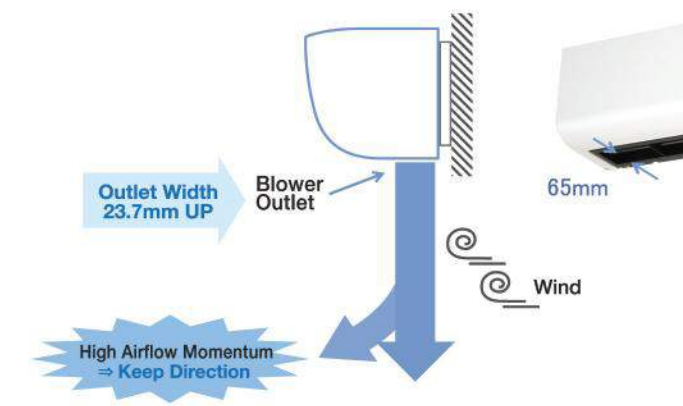

Highly Durable

- Resin with glass fiber material is used in the Hybrid Cross Flow Fan incorporated with the metal bosh, the durability is prolonged significantly.



Easy Maintenance

- The Cross Flow Fan can generate air current between the fan and front cover forming movement of dust that reduces accumulation of dust on the fan blade.
- Simple structure allows convenient cleaning of the fan - just detach the front cover to clean the fan blade.

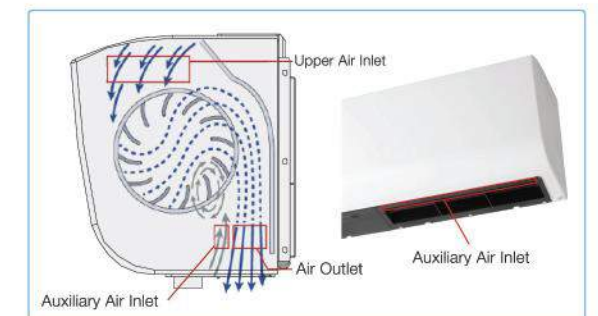

## FY-3509U1/ FY-4009U1 Standard Type - 900mm



- Cross flow fan for wide and uniform airflow
- Unique auxiliary air inlet enhances airflow output
- Thick air stream provides high airflow momentum
- Resin with glass fiber adopted for fan blade
- Metal blade bush for high durability
- Simple structure for easy maintenance
- Air deflection plate for airflow direction adjustment
- Main air inlet at top allows neat image

### Dimension Unit: mm

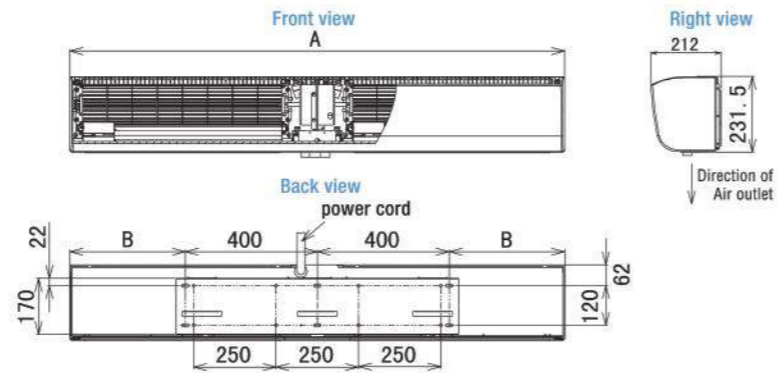

Model No.	A	B
FY-3509U1	900	50
FY-4009U1	900	50

### Specification

Model No.	Hz		Consumption [W]	Air Volume		Current [A]	Outlet Velocity [m/s]	Noise [dB(A)]	Weight [kg]
				[CMH]	[CFM]				
FY-3509U1	50	Hi	95	1150	676	0.41	11.0	51.0	12
		Lo	85	1000	588	0.39	9.0	49.0	
FY-4009U1	50	Hi	110	1340	788	0.50	12.0	54.5	12.5
		Lo	94	1190	700	0.43	10.0	51.0	

Note: The Value In Specification tables are representative characteristic value at 220V, 50Hz

## FY-3512U1/ FY-4012U1 Extra Type - 1200mm



- Cross flow fan for wide and uniform airflow
- Unique auxiliary air inlet enhances airflow output
- Thick air stream provides high airflow momentum
- Resin with glass fiber adopted for fan blade
- Metal blade bush for high durability
- Simple structure for easy maintenance
- Air deflection plate for airflow direction adjustment
- Main air inlet at top allows neat image

### Dimension Unit: mm

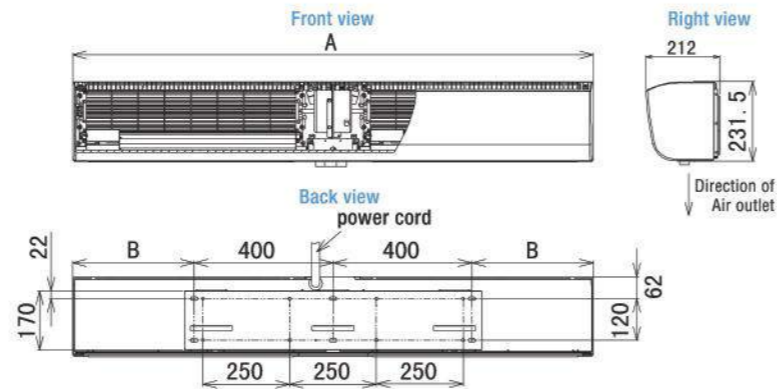

Model No.	A	B
FY-3512U1	1200	200
FY-4012U1	1200	200

### Specification

Model No.	Hz		Consumption [W]	Air Volume		Current [A]	Outlet Velocity [m/s]	Noise [dB(A)]	Weight [kg]
				[CMH]	[CFM]				
FY-3512U1	50	Hi	114	1550	912	0.49	10.5	49.0	14.5
		Lo	100	1300	765	0.46	8.5	46.0	
FY-4012U1	50	Hi	126	1700	1000	0.59	12.0	52.5	15.5
		Lo	105	1530	900	0.49	10.0	48.5	

Note: The Value In Specification tables are representative characteristic value at 220V, 50Hz

## HAND DRYER



Power Dry hand dryer provides a comfortable and speedy hand drying experience by removing moistures on hands with warm and high velocity airflow. In addition, environment protection and cost saving are achieved by comparing with using paper towel.

### New Features of FJ-T09A3/ FJ-T09B3

#### Safe Operation

- Power Dry will stop after 60 seconds of continuous operation.
- "Check" indicator will light up when the unit detects overheated.

#### Quick Response Sensor

- Automatic sensor operation, no physical contact is required to activate the unit.

#### Heater ON/OFF Switch

- Heater can be switched off for energy saving in hot season.

#### Full Tank Indicator (FJ-T09A3 only)

- Remind you for cleaning up the water tank when it is full.

#### Quick Drying with 3 way Airflow

##### Wide Nozzle

Blow off water droplets on the whole palm with wide airflow.

##### Spot Nozzle

Dry fine water droplets by rubbing hands with spot airflow.

2 kinds of nozzle, wide nozzle and spot nozzle, are equipped at front and rear of drying chamber respectively for efficient drying. The new structure realizes quick drying in only 4-9 seconds.



#### Easy Installation

- Metallic bracket for wall hanging attached.
- Stylish and streamline design fits most interior.

#### Anti-bacteria Material

- The product body is adopted with anti-bacteria material to prevent the growth of bacteria and germs in the warm and humid environment of washroom.

#### Drain Pan (FJ-T09A3 only)

- Drain pan can reduce water dripping on floor to avoid slippery.



#### Super alleru-buster Filter

- The filter is equipped to ensure the air blow to your hand is clean.

#### What is Super alleru-buster?

Super alleru-buster can inhibit up to several types of allergen.



Testing Organization: The Osaka Municipal Technical Research Institute.  
Testing Method: to measure the level of reduction in cat's dandruff by Enzyme-linked Immuno Sorbent Assay.



FJ-T09A3  
With Drain Pan



FJ-T09B3  
Without Drain Pan

- Powerful air velocity enables drying time in few seconds
- Automatic operation by infra-red motion sensor
- Super-allergo buster filter equipped
- Anti-bacteria material adopted
- Heater ON/OFF switch for energy saving
- Safety check light function terminate the operation in case overload
- Drain pan and water tray equipped (FJ-T09A3 only)

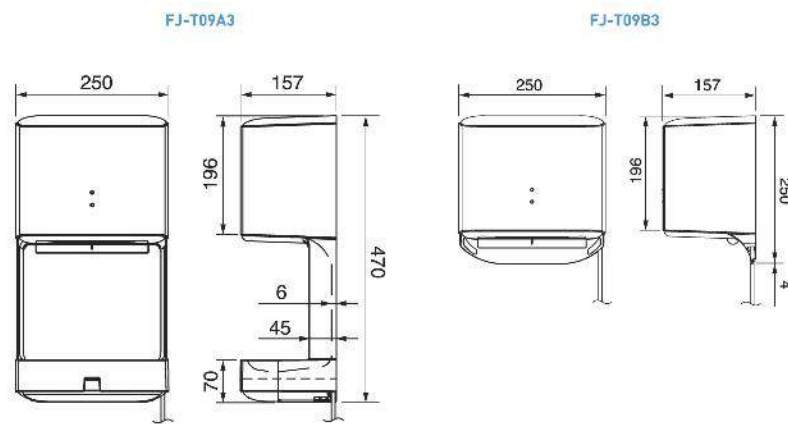

Specification

Model No.	Power Consumption [W]		Air Velocity [m/s]	Noise [dB(A)]	Drain Pan	Weight [kg]
	Heater ON	Heater OFF				
FJ-T09A3	1,020	650	90-110	62	Yes	4
FJ-T09B3	1,020	650	90-110	62	No	3.5

Note: The value in Specification table are representative characteristics value at 220V, 50Hz.

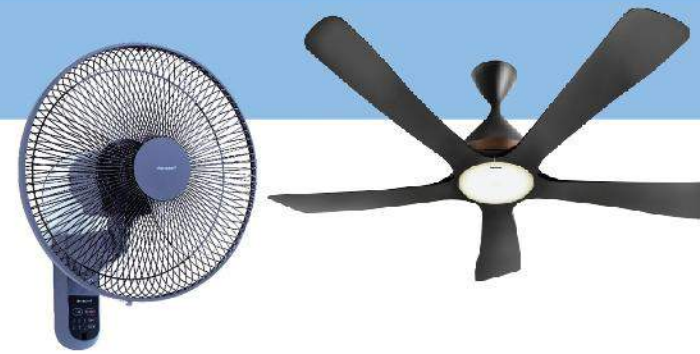

CEILING FAN  
ELECTRIC FAN

Safety Features for Ceiling Fan

1 Cut-off Safety Switch  
Patents registration in Japan, The United States, China, Malaysia and Vietnam

Problem

In case there is any wear at either the shaft or the bolt, abnormal wobbling of fan will occur as it runs. The wear will be further enlarged if the fan continues to operate, and the part or fastener will break eventually.

Our solution

Cut-off safety switch is equipped to cut off power supply while dangerous wear and tear of the shaft or bolt are detected. As abnormal wobbling occurs, the lever will detach from the switch and the fan will stop. It will prevent further wear to the damaged part. It can minimize the fracture of the part that reduces the possibility of falling of fan.

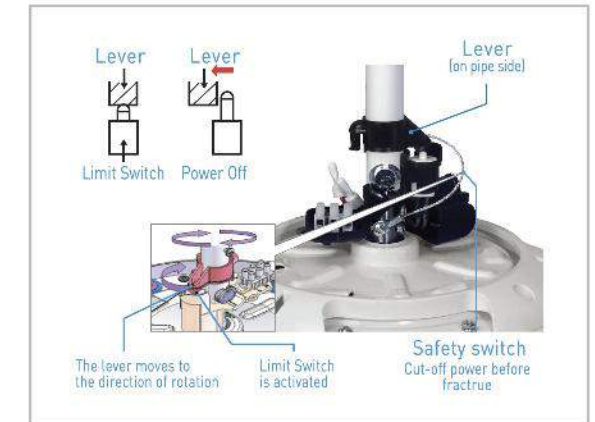

2 Safety Plate  
- Patents are being applied in The United States, China, Malaysia, Vietnam and India  
- The application number for Safety Plate is P50072

Problem

Blade fins may fall from the fan motor in case fatigue of material occurs.

Our solution

An exclusively designed fall prevention plate is installed on the blade. This mechanism secures against falling of blades caused by damaging wearing.



3 Safety Wire

Problem

Fan motor may fall from the pipe rod accidentally whatever any factors, such as wearing of shaft bolt, etc.

Our solution

Safety wire is adopted to secure the fan motor with the ceiling hook that prevents falling of the motor when detaching of the fan motor from the pipe rod occurs.

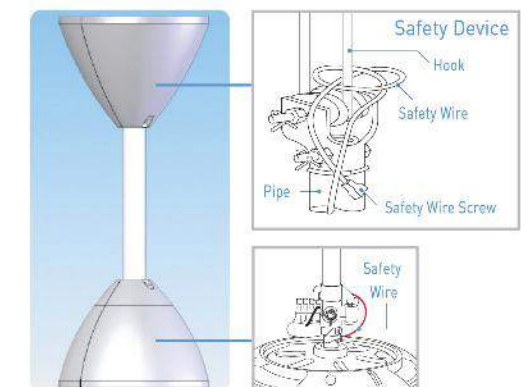

## Other Features

### 1 1/f Yuragi (Natural Breeze) *1/f yuragi*

These fans are equipped with 1/f Yuragi function which is a fluctuated pattern acting a gentle breeze. By this sophisticated formula, in varying air velocity and controlling wind force, these new ceiling fans present you a peaceful and comfortable feeling.

#### Current function rhythm breeze

Speed notch toggles by 4 seconds regularly.

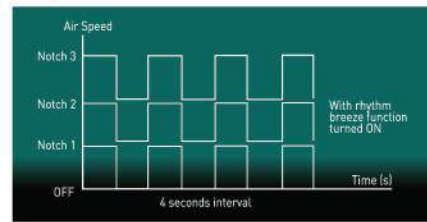

This regular pattern makes body temperature falling after a period of time. After that, you may feel anxious and uncomfortable when the wind velocity changes.

#### New function 1/f Yuragi

Speed notch toggles based on Yuragi pattern.

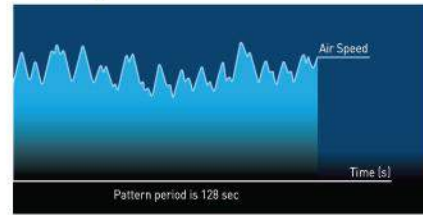

Incorporated with this human-concerned technology, this kind of rhythm maintains your external body temperature by giving you a feeling of natural wind when there is a change of wind velocity.

### 2 3D Blade (Powerful Airflow)

With the exclusive and unique 3D blade design, it provides a smooth and strong air flow while maintaining operating noise in low level.

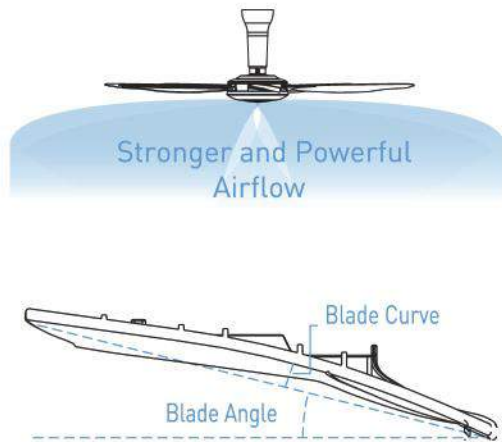

3D curve design in the center of blade effectively catch the air.

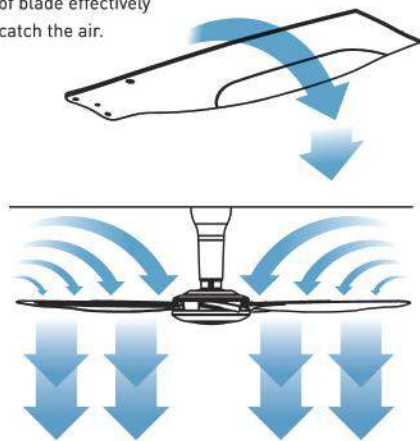

### 3 ON Timer

On Timer can be incorporated with air conditioner to realize economy and comfortable operation. It can minimize excessive cold feeling and save power consumption during your sleep.



### 4 Sleep Mode

The fan is equipped with Sleep Mode, by which fan speed and timer will gradually go down until the fan is off. The function not only creates an optimal sleeping environment, but also enhances energy saving as well.

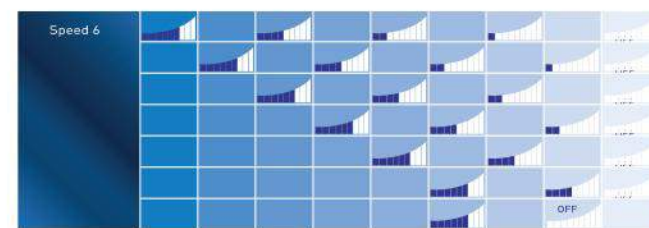

### 5 LED Lamp

The embedded LED illumination lamp has 4 selections of color: Cool White, Day Light, Neutral White or Warm White. Incorporated with contemporary interior, they can foster a charming atmosphere to the room.

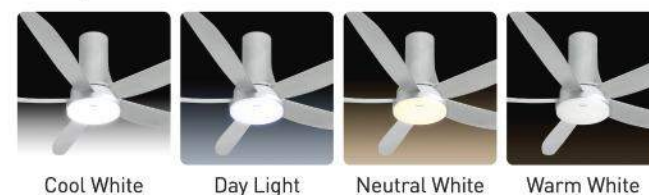

### 6 Direct Current Motor (F-60UFN, F-60TAN, F-60TDN)

Newly developed direct current (DC) motor are adopted in these fans. Power consumption is reduced as compared with alternative current (AC) motor that energy saving is achieved. DC motor has lighter weight compared with conventional AC motor, that allows easy handling for DC ceiling fan.

#### Direct Current (DC) Motor

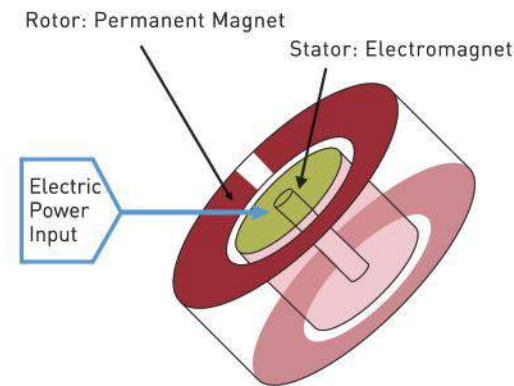

Electric power input is required for stator only

#### Alternating current (AC) Motor

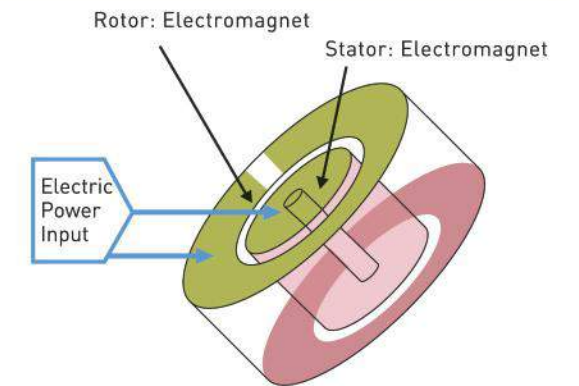

Electric power input is required for both rotor and stator

### 7 Auto Mode with ECONAVI Function

F-60TAN is equipped with temperature sensor. Incorporated with ECONAVI function, the innovative Auto Mode function is enhanced. This function controls the fan to generate the most comfortable air velocity to human body subject to the change of room temperature.

The sensor monitors the surrounding temperature change and air velocity will vary automatically in accordance with below table.

Range of Room Temperature	Change of Room Temperature		Change of Speed F-60TAN	
	-1°C	+1°C	-	+
Above 30°C	Blue bar	Red bar	Blue bar	Red bar
30°C - 29°C	Blue bar	Red bar	Blue bar	Red bar
29°C - 24°C	Blue bar	Red bar	Blue bar	Red bar
Below 24°C	Blue bar	Red bar	No Change	No Change

# Speed change for ECONAVI is among speed 1 to speed 9

### 8 Comfort Eco (F-60TAN)

The figure illustrates the effect of using air conditioner and ceiling fan with 'Auto Mode'. The fan speed is adjusted according to room temperature monitored by the thermal sensor. Room temperature decreases to 28°C over a period, while the sensible temperature could be maintained to 26.7°C, which is said to be most comfortable to human body.

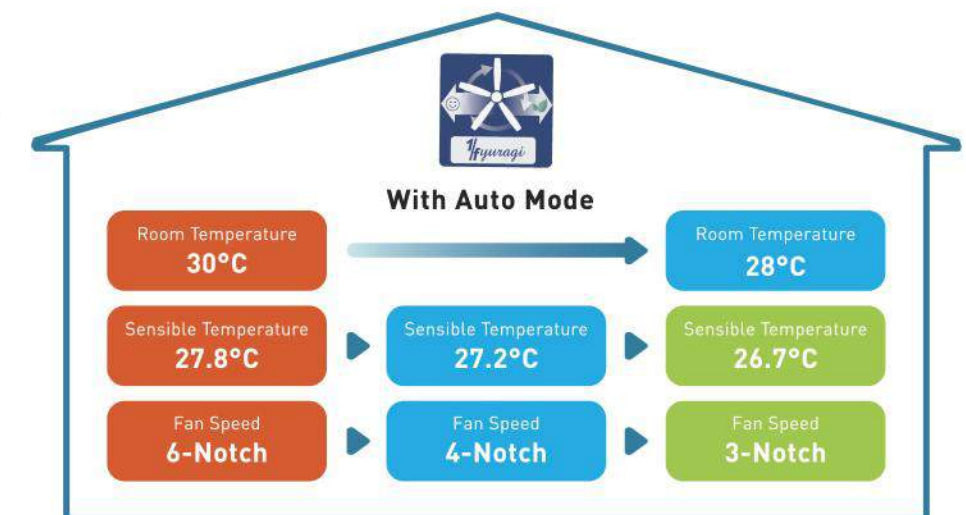

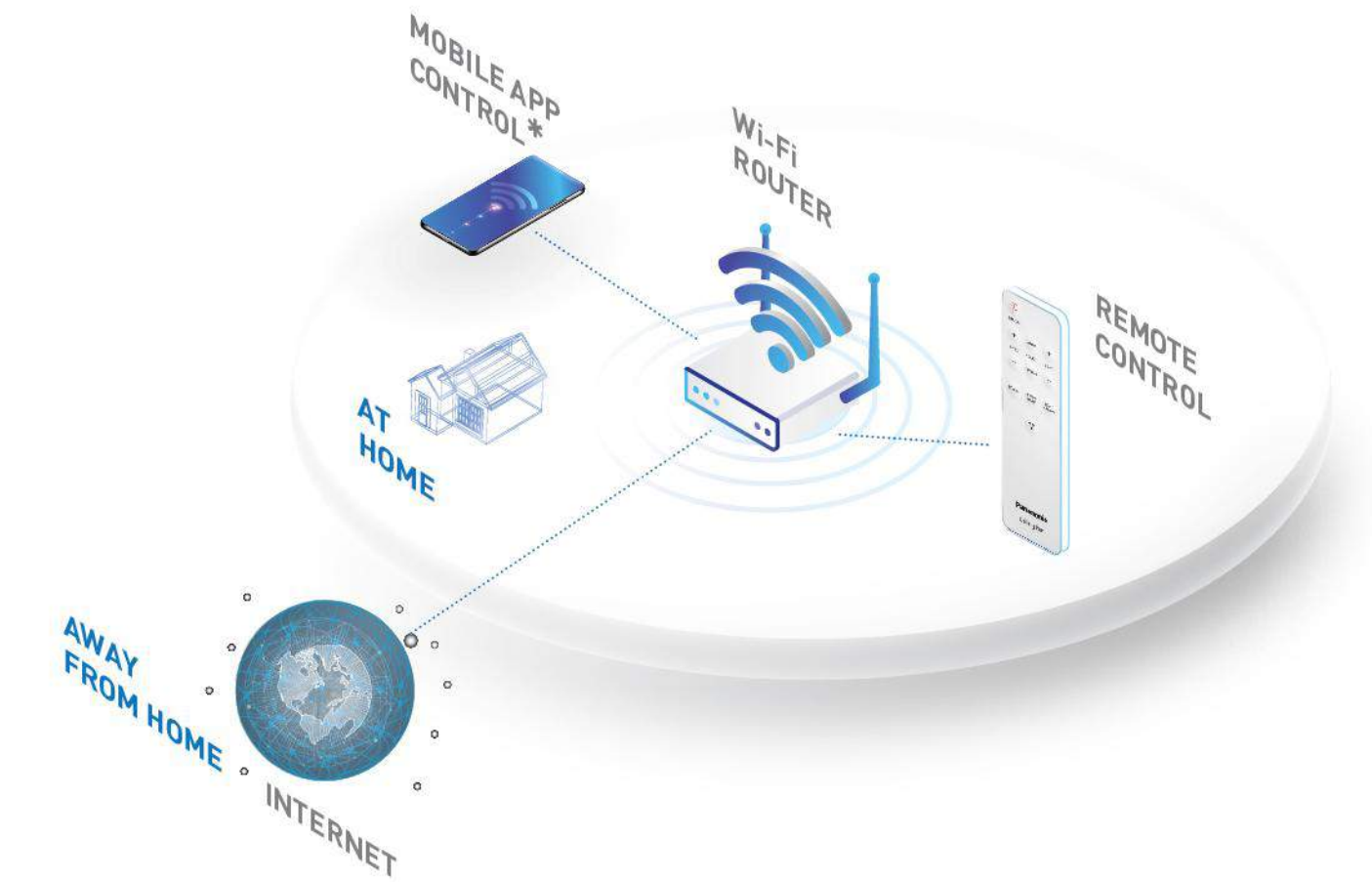

**REMOTELY CONTROL AWAY FROM HOME \***

- \*One user account can only control up to 8 Wi-Fi ceiling fans
- \*One Wi-Fi ceiling fan can only be registered by 4 user accounts



**Mobile Application Control**

App-enabled\* ceiling fan that connects to your Wi-Fi network and allows user to control their fans using mobile devices.

\*Requires Android 6 and above or iOS 12 and above for the app to work.

**F-60DGN Ceiling Fan - Wireless Connection Deluxe Series**



- Direct function: Fan and Light
- New generation DC motor
- Wireless 2.4 GHz
- Mobile application control (iOS/Android)
- LED lighting with brightness for daily life
- 1/2 Yuragi Function
- Reverse function to operate with Air conditioner
- ABS-GF blade material for durability
- 24 hours On & Off timer
- Equipped with safety device
- Color: Black

**Dimension**  
Unit: mm

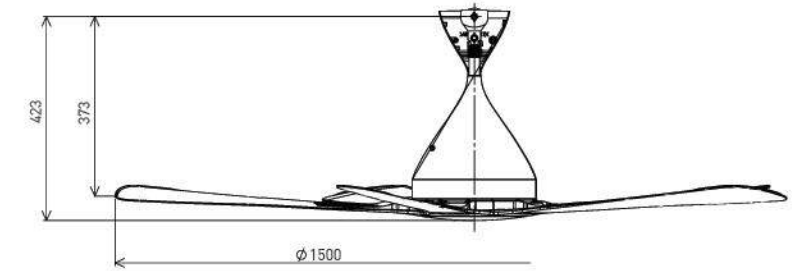

**Specification**

Model No.	Voltage		Consumption		Air Velocity		Air Delivery		Weight [kg]
	[V]	[Hz]	Fan	Fan+Light	[m/min]	[ft/min]	[m³/min]	[ft³/min]	
F-60DGN	220	50	54	73	160	656	300	8,299	7.3

Note: The value in Specification table are representative characteristics value at 220V, 50Hz. R.P.M. data is for reference only, values may vary subject to different conditions.

**F-60DHN Ceiling Fan - Wireless Connection Deluxe Series**



- New generation DC motor
- Wireless 2.4 GHz
- Mobile application control (iOS/Android)
- 1/2 Yuragi Function
- Reverse function to operate with Air conditioner
- ABS-GF blade material for durability
- 24 hours On & Off timer
- Equipped with safety device
- Color: Black

**Dimension**  
Unit: mm

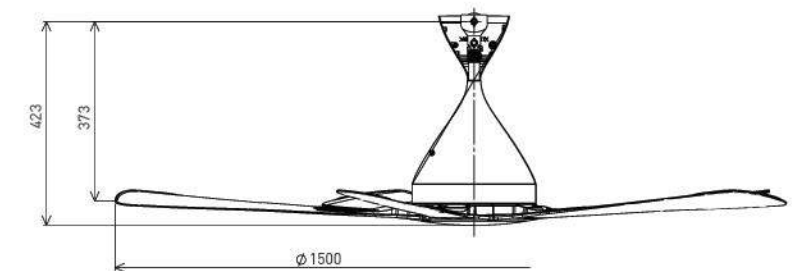

**Specification**

Model No.	[V]	*	Consumption [W]	R.P.M. [min <sup>-1</sup> ]	Air Velocity [m/min]	Air Delivery [m³/min]	Weight [kg]
F-60DHN	220	Hi	54	245	160	300	7.0
		Lo	4	80			

\* Hi - Notch 9 / Lo - Notch 1  
Note: The value in Specification table are representative characteristics value at 220V, 50Hz. R.P.M. data is for reference only, values may vary subject to different conditions.



## F-48DGL Ceiling Fan - Wireless Connection Deluxe Series



Dimension  
Unit: mm

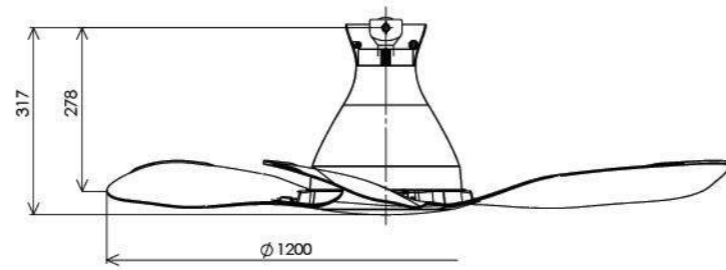

### Specification

Model No.	Voltage		Consumption		Air Velocity		Air Delivery		Weight [kg]
	[V]	[Hz]	Fan	Fan+Light	[m/min]	[ft/min]	[m³/min]	[ft³/min]	
F-48DGL	220	50	31	50	185	656	200	8,299	5.2

Note: The value in Specification table are representative characteristics value at 220V, 50Hz. R.P.M. data is for reference only, values may vary subject to different conditions.

- Direct function: Fan and Light
- New generation DC motor
- Wireless 2.4 GHz
- Mobile application control (iOS/Android)
- LED lighting with brightness for daily life
- 1/f Yuragi Function
- Reverse function to operate with Air conditioner
- ABS-GF blade material for durability
- 24 hours On & Off timer
- Equipped with safety device
- Color: Black

## LIGHTING SCENE SETTING

[Applicable for F-60DGN & F-48DGL]

Preset with 4 light setting for 4 common daily activities.

The preset scene can also be overwritten by adjusting the light setting according to your preferred comfort level and save the setting for easy 1-Touch access.

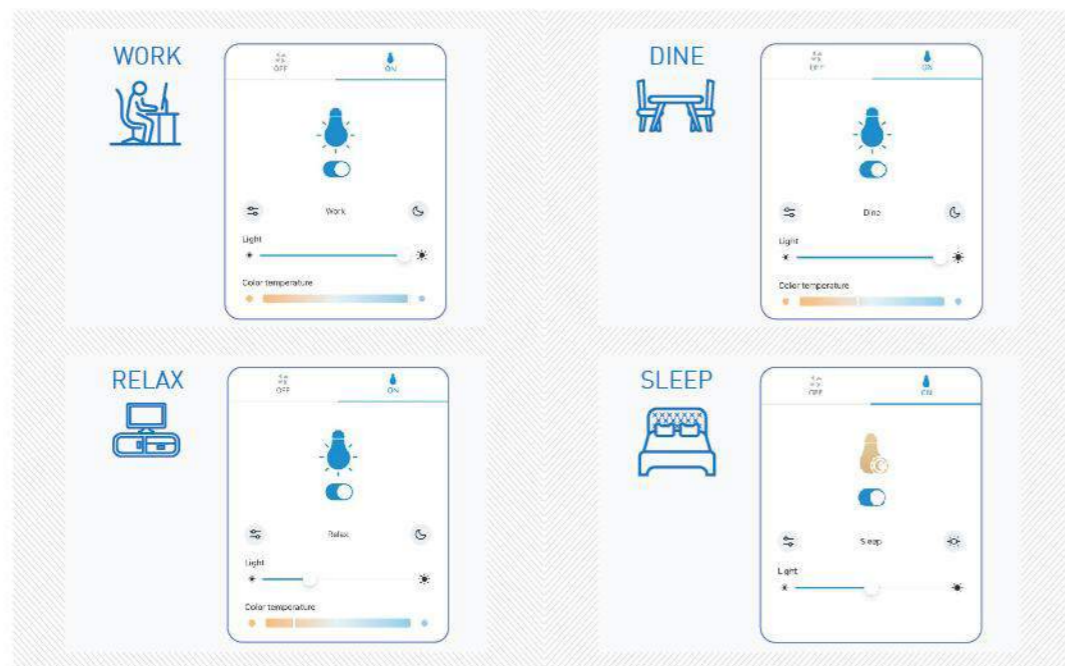

## F-60UFN Ceiling Fan - Super Deluxe Series



Dimension  
Unit: mm

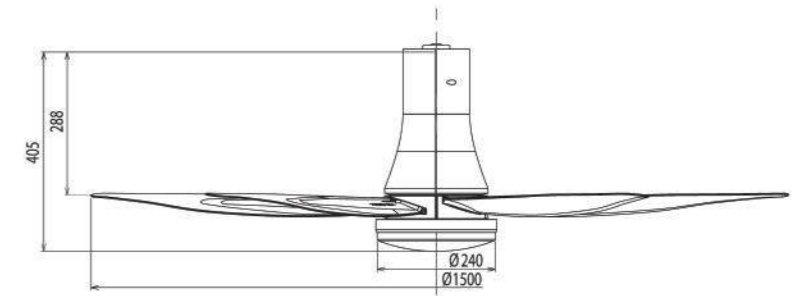

### Specification

Model No.	Voltage		Consumption		Air Velocity		Air Delivery		Weight [kg]
	[V]	[Hz]	Fan	Fan+Light	[m/min]	[ft/min]	[m³/min]	[ft³/min]	
F-60UFN	220	50	37	59	200	656	235	8,299	6.2

Note: The value in Specification table are representative characteristics value at 220V, 50Hz. R.P.M. data is for reference only, values may vary subject to different conditions.

- Dual function: Fan and Light
- Direct Current (DC) motor adopted
- LED lighting with brightness for daily life
- Selectable light color (White/Daylight/Warm)
- 5-PPG Blade material for durability
- 1/f Yuragi Function
- LCD wireless remote control
- Equipped with safety device
- 1-8 hours On & Off timer
- 2-8 hours Sleep mode
- Color: Silver

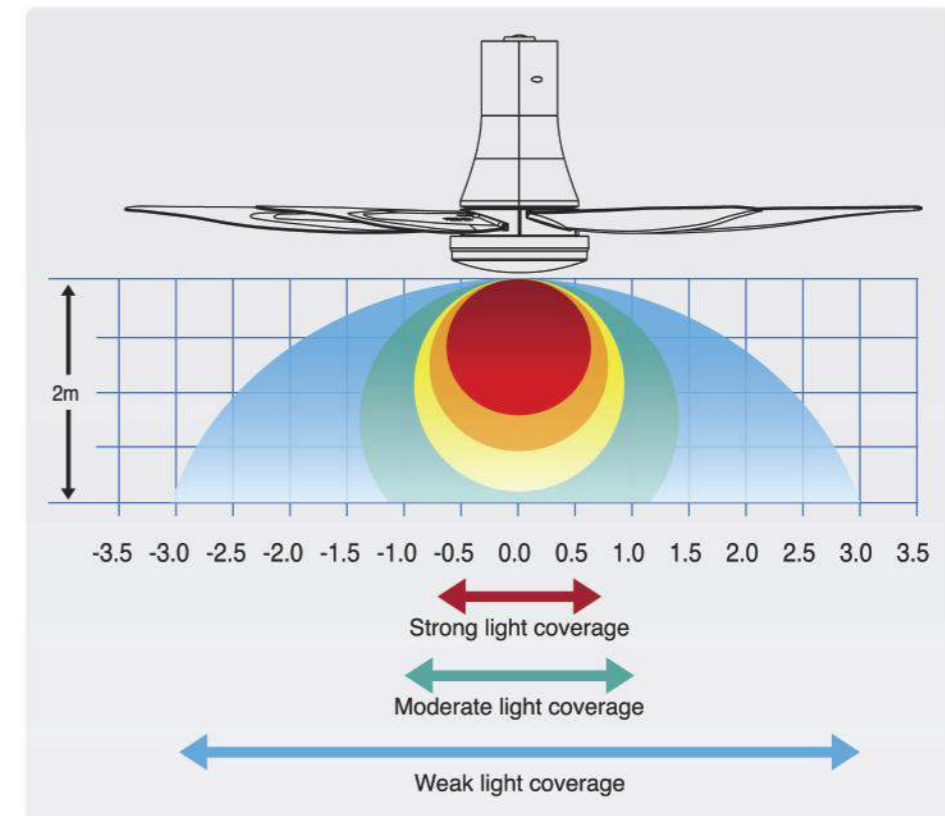

## F-60TDN Ceiling Fan- Deluxe Series



- Direct current (DC) motor adopted
- 1/f Yuragi function
- 3D blade delivers smooth and strong airflow
- PPG blade material for durability
- LCD wireless remote control
- 9-speed control
- Sleep mode with On timer & Off timer
- Equipped with safety device
- Blade safety plate and safety wire attached

### Dimension Unit: mm

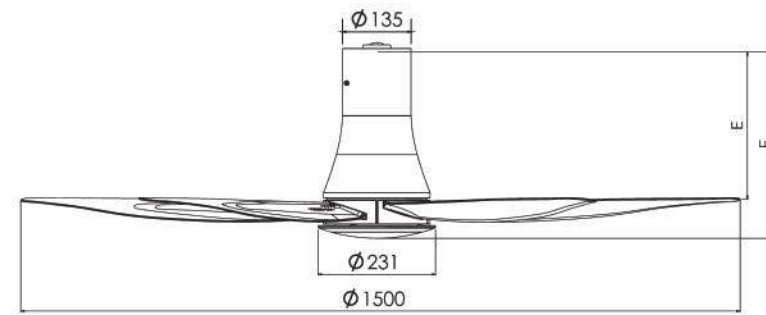

Pipe Type	Short	Long
E	212	288
F	290	366

### Specification

Model No.	[V]	*	Consumption [W]	R.P.M. [min <sup>-1</sup> ]	Air Velocity [m/min]	Air Delivery [m <sup>3</sup> /min]	Weight [kg]
F-60TDN	220	Hi	37	228	200	235	5.3
		Lo	3	80			

\* Hi - Notch 9 / Lo - Notch 1  
Note: The value in Specification table are representative characteristics value at 220V, 50Hz. R.P.M. data is for reference only, values may vary subject to different conditions.

## F-60WWK Ceiling Fan- Deluxe Series



- 1/f Yuragi function
- 3D blade delivers smooth and strong airflow
- PPG blade material for durability
- LCD wireless remote controller
- 7 speed control
- Sleep mode
- 8-hour off timer
- Equipped with cut-off safety device
- Blade safety plate attached
- Safety wire adopted

### Dimension Unit: mm

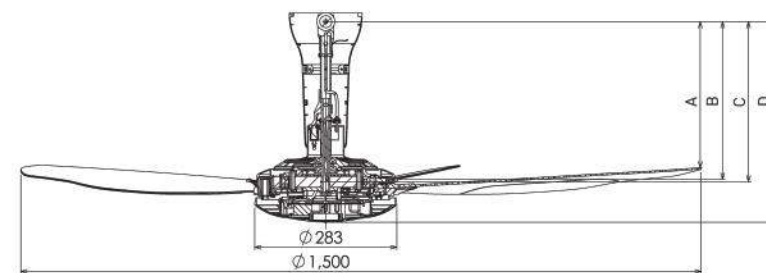

Pipe Type	Short	Long
A Blade	196	291
B Deco Cover	219	315
C Stator Center	224	320
D PCB Cover	304	400

### Specification

Model No.	[V]	*	Consumption [W]	R.P.M. [min <sup>-1</sup> ]	Air Velocity [m/min]	Air Delivery [m <sup>3</sup> /min]	Weight [kg]
F-60WWK	220	Hi	76	183	191	220	8
		Lo	22	83			

\* Hi - Notch 9 / Lo - Notch 1  
Note: The value in Specification table are representative characteristics value at 220V, 50Hz. R.P.M. data is for reference only, values may vary subject to different conditions.

## F-56XPG Ceiling Fan - Wireless Remote Control Series



- 3-speed selection
- Wireless remote control
- Off timer with LED indicator (1, 3, 6 hours)
- Sleep mode
- Thermal cutoff prevent overheating
- Current fuse secure against power surge
- Safety wire provided
- Wobbling reduction mechanism prevent fan falling
- Fall prevention of blade adopted
- Permanently lubricated ball bearing equipped
- Painted steel blades
- Color: Black or White

### Dimension Unit: mm

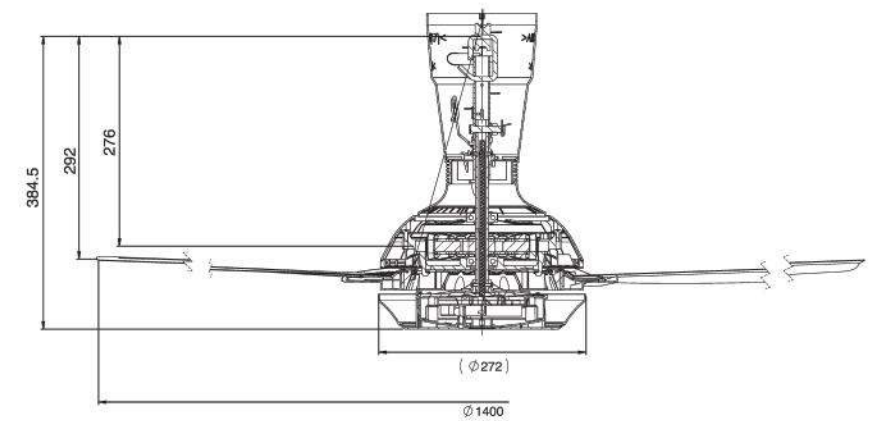

### Specification

Model No.	[V]	*	Consumption [W]	R.P.M. [min <sup>-1</sup> ]	Air Velocity [m/min]	Air Delivery [m <sup>3</sup> /min]	Weight [kg]
F56XPG	220	Hi	59	170	142	191	6.7
		Lo	16	87			

\* Hi - Notch 9 / Lo - Notch 1  
Note: The value in Specification table are representative characteristics value at 220V, 50Hz. R.P.M. data is for reference only, values may vary subject to different conditions.

## F-56MPG Ceiling Fan - Wireless Remote Control Series



- Wireless remote controller
- 3-speed selection
- 1, 3, 6 hours timer
- Sleep mode
- Thermal fuse prevent overheating or power surge
- Safety wire provided
- Cut-off safety switch equipped
- Fall prevention of blade adopted
- Permanently lubricated ball-bearing assembly
- Color: Gold or Silver

### Dimension Unit: mm

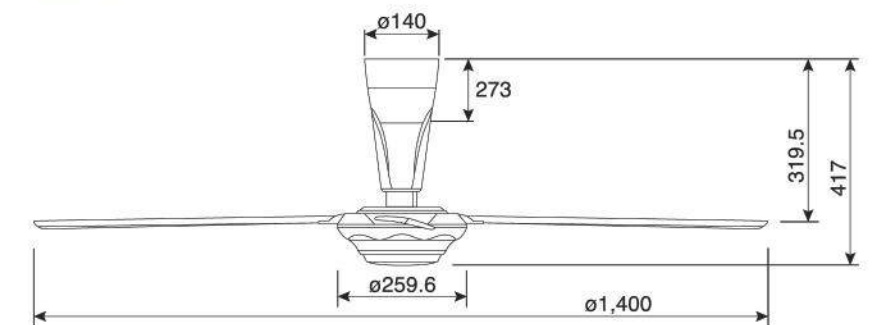

### Specification

Model No.	[V]	*	Consumption [W]	R.P.M. [min <sup>-1</sup> ]	Air Velocity [m/min]	Air Delivery [m <sup>3</sup> /min]	Weight [kg]
F56MPG	220	Hi	64	92	150	180	7
		Lo	59	88			

\* Hi - Notch 9 / Lo - Notch 1  
Note: The value in Specification table are representative characteristics value at 220V, 50Hz. R.P.M. data is for reference only, values may vary subject to different conditions.

## F-56MZG Ceiling Fan - Wireless Remote Control Series



- Wireless remote controller
- 3-speed selection
- 1, 3, 6 hours timer
- Sleep mode
- Thermal fuse prevent overheating or power surge
- Safety wire provided
- Cut-off safety switch equipped
- Fall prevention of blade adopted
- Permanently lubricated ball-bearing assembly
- Color: Gold or Silver

### Dimension Unit: mm

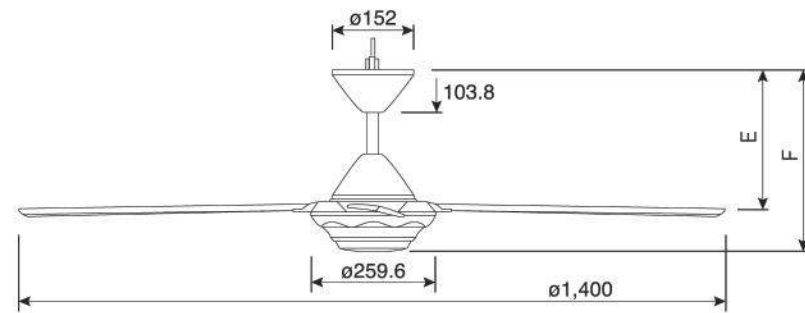

Pipe Type	9 inch	12 inch	16 inch	16 inch	22 inch
Pipe Length	229	305	406	457	559
E	332.5	408.5	509.5	560.5	662.5
F	430.0	506.0	607.0	658.0	760.0

### Specification

Model No.	[V]	*	Consumption [W]	R.P.M. [min <sup>-1</sup> ]	Air Velocity [m/min]	Air Delivery [m <sup>3</sup> /min]	Weight [kg]
F56MZG	220	Hi	64	92	150	180	6.9
		Lo	59	88			

\* Hi - Notch 9 / Lo - Notch 1

Note: The value in Specification table are representative characteristics value at 220V, 50Hz. R.P.M. data is for reference only, values may vary subject to different conditions.

## F-56NCL Ceiling Fan - Classic Series



- Compact size condenser controlled regulator
- 5-speed selection
- Thermal fuse prevent overheating or power surge
- Safety wire provided
- Cut-off safety switch equipped
- Fall prevention of blade adopted
- Permanently lubricated ball bearing assembly
- Color: Brown

### Dimension Unit: mm

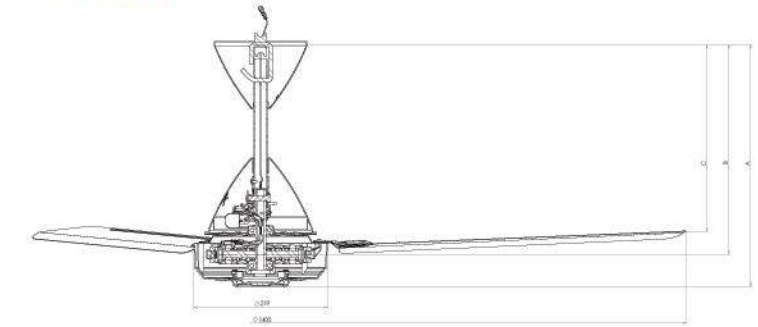

Pipe Type	12 inch	18 inch
A	513	665
B	466	618
C	366	518

### Specification

Model No.	[V]	*	Consumption [W]	R.P.M. [min <sup>-1</sup> ]	Air Velocity [m/min]	Air Delivery [m <sup>3</sup> /min]	Weight [kg]
F-56NCL	220	Hi	70	268	165	220	5.2
		Lo	14	103			

## F-60MZ2 Ceiling Fan - Regulator Control Series



- Compact size condenser controlled regulator
- 5-speed selection
- Thermal fuse prevent overheating or power surge
- Safety wire provided
- Cut-off safety switch equipped
- Fall prevention of blade adopted
- Permanently lubricated ball-bearing assembly
- Color: Black or White

### Dimension Unit: mm

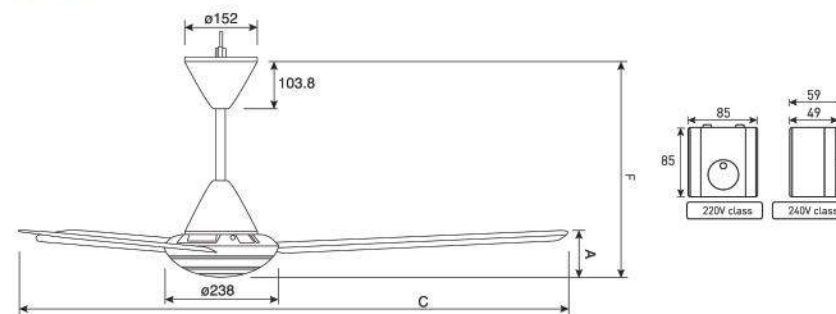

Pipe Type	9 inch	12 inch	16 inch	18 inch	22 inch	Model No.	A	C
Pipe Length	229	305	406	457	559	F-60MZ2	84.2	1,500
F	375.7	451.7	552.7	603.7	705.7			

### Specification

Model No.	[V]	*	Consumption [W]	R.P.M. [min <sup>-1</sup> ]	Air Velocity [m/min]	Air Delivery [m <sup>3</sup> /min]	Weight [kg]
F60MZ2	220	Hi	66	225	150	215	5.7
		Lo	15	94			

\* Hi - Notch 9 / Lo - Notch 1

Note: The value in Specification table are representative characteristics value at 220V, 50Hz. R.P.M. data is for reference only, values may vary subject to different conditions.

## F-48CZL Ceiling Fan - Bedroom Series



- Wireless remote controller
- 3-speed selection
- Sleep mode
- 1,3,6 hours timer
- Thermal fuse prevent over heating or power surge
- Safety wire provided
- Cut-off safety switch equipped
- Fall prevention ff blade adopted
- Permanently lubricated ball bearing equipped
- Color: Silver

### Dimension Unit: mm

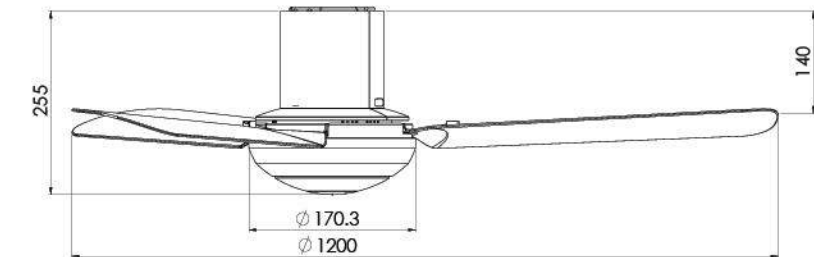

### Specification

Model No.	[V]	*	Consumption [W]	R.P.M. [min <sup>-1</sup> ]	Air Velocity [m/min]	Air Delivery [m <sup>3</sup> /min]	Weight [kg]
F-48CZL	220	Hi	55	209	150	160	5.5
		Lo		171			

## F-70ZBP Ceiling Fan – Mid Fan Series



- Twin direct current (DC) motor technology
- Motion sensor equipped
- Big size fan blades for higher air delivery
- LCD wireless remote control with 9 speed selection
- 1/2 Yuragi function
- PPG blade material with aluminum blade extension
- Sleep mode and 8-hour on/off timer
- Thermal cutoff prevent overheating
- Current fuse secure against power surge
- Safety wire provided
- Cut-off safety switch equipped
- Fall prevention of blade adopted
- Permanently lubricated ball bearing equipped
- Color: Black or White

### Dimension Unit: mm

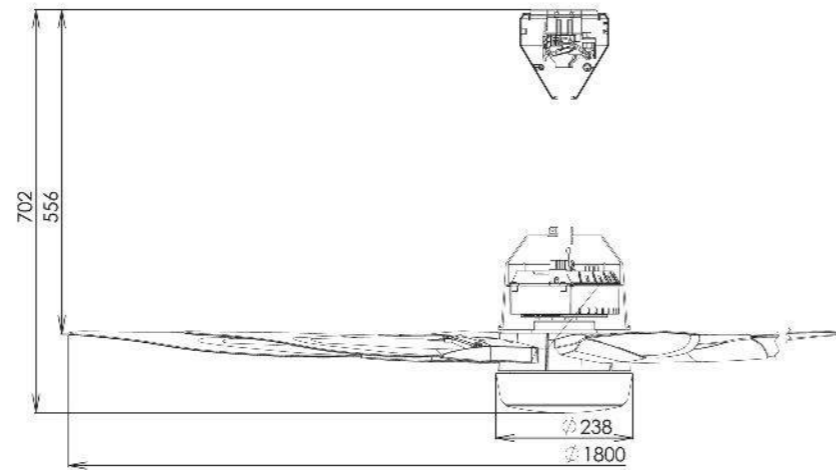

### Specification

Model No.	[V]	*	Consumption [W]	R.P.M. [min <sup>-1</sup> ]	Air Velocity [m/min]		Air Delivery [m <sup>3</sup> /min]	Weight [kg]
F-70ZBP	220	Hi	51	185	185	310		11.9
		Lo	5	80				

## F-409Q Cycle Fan



- Oscillation over 360°
- 5-speed and on/off by wired regulator
- Easy angle adjustment
- Metal blade
- Color: Blue or Gold

### Adjustment of Circulating Angle

The oscillation angle can be adjusted to 15,30 or 50 degrees.

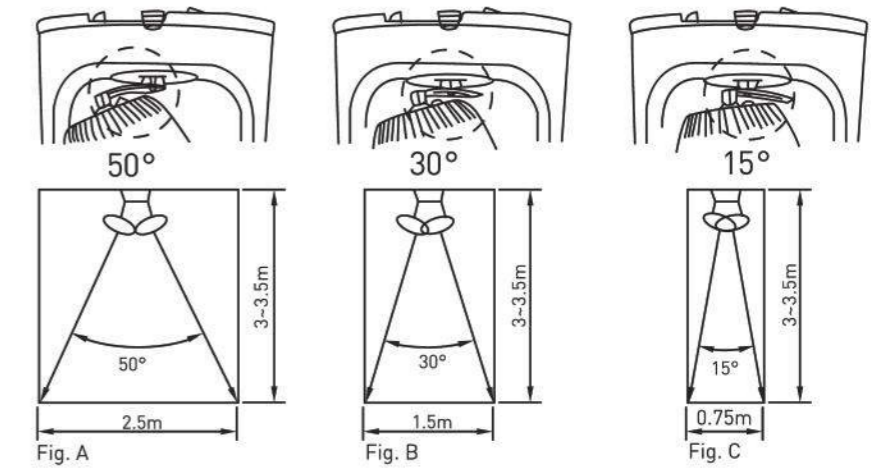

### Specification

Model No.	[V]	*	Consumption [W]	R.P.M. [min <sup>-1</sup> ]	Air Velocity		Air Delivery		Weight [kg]
					[m/min]	[ft/min]	[m <sup>3</sup> /min]	[ft <sup>3</sup> /min]	
F-409Q	220	Hi	46.8 - 57.2	1,080 - 1,320	256	840	79	2,790	4.3
		Lo	22.5 - 27.5	690 - 850					

Note: The value in Specification table are representative characteristics value at 220V, 50Hz. R.P.M. data is for reference only, values may vary subject to different conditions.

## F-80ZBR Ceiling Fan – Mid Fan Series



- Twin direct current (DC) motor technology
- Motion sensor equipped
- Big size fan blades for higher air delivery
- LCD wireless remote control with 9 speed selection
- 1/2 Yuragi function
- PPG blade material with aluminum blade extension
- Sleep mode and 8-hour on/off timer
- Thermal cutoff prevent overheating
- Current fuse secure against power surge
- Safety wire provided
- Cut-off safety switch equipped
- Fall prevention of blade adopted
- Permanently lubricated ball bearing equipped
- Color: Black or White

### Dimension Unit: mm

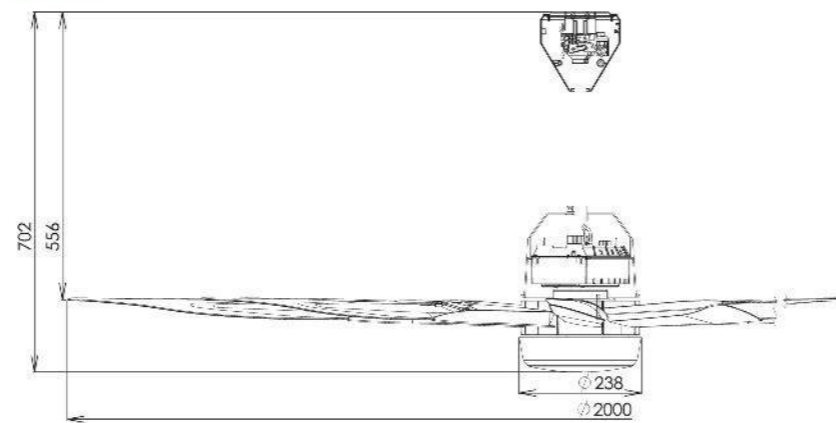

### Specification

Model No.	[V]	*	Consumption [W]	R.P.M. [min <sup>-1</sup> ]	Air Velocity [m/min]		Air Delivery [m <sup>3</sup> /min]	Weight [kg]
F-80ZBR	220	Hi	57	150	165	345		13.5
		Lo	4	50				

## F-50YUZ Wall Fan – Cord Operated Type



- Guide Vane design generates strong and focus air flow up to 10 metre distance
- Aluminium blade for stronger air flow and durability
- Added angle adjust bolt for extra stability on the fan's knee joint
- Full automatic oscillation
- 3 speed ON/OFF pull switch
- New and modern Front Guard design
- Suitable for installation at various places with sleek outlook

### Dimension Unit: mm

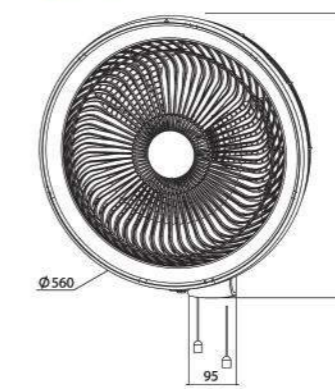

### Specification

Model No.	[V]	*	Consumption [W]	R.P.M. [min <sup>-1</sup> ]	Air Velocity [m/min]		Air Delivery [m <sup>3</sup> /min]	Weight [kg]
F-50YUZ	220	Hi	63	1230	300	110		6
		Lo	53	850				

## F-409U Wall Fan - Cord Operated Type



- Oscillation control
- 3-speed and on/off by pull switch
- Easy angle adjustment
- Blade - Metallic material
- Color: Blue or Gold

### Adjustment of Circulation Angle "One-touch" adjustment of tilt

The air flow can be adjusted upward or downward by simply moving the guard up or down as shown in the figure. Adjust the angle of the fan only after first confirming that it has stopped rotating.

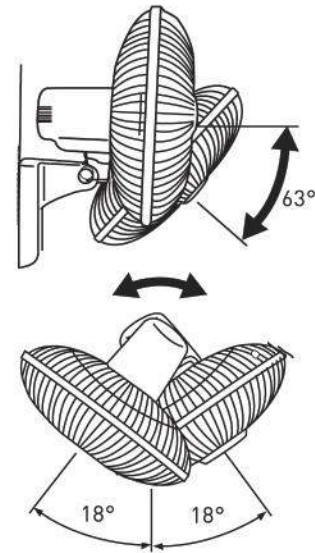

### Double oscillation

To change the direction of the air flow, push the edge of the guard to the desired position.

### Specification

Model No.	[V]	•	Consumption [W]	R.P.M. [min <sup>-1</sup> ]	Air Velocity		Air Delivery		Weight [kg]	
					[m/min]	[ft/min]	[m <sup>3</sup> /min]	[ft <sup>3</sup> /min]		
F-409U	50		Hi	42.8 - 51.2	1058 - 1293	226	741	63	2,225	4.4
			Lo	33.6 - 41.1	764 - 933					

Note: The value in Specification table are representative characteristics value at 220V, 50Hz. R.P.M. data is for reference only, values may vary subject to different conditions.

## F-409K 40cm [16"]

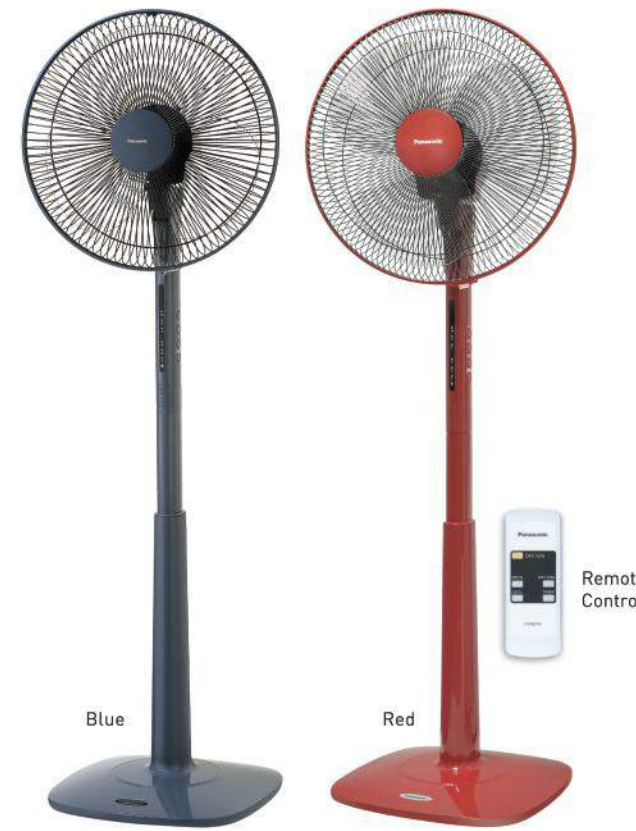

- Wireless remote control
- 3-speed and off electronic switch
- Rhythm breeze function
- Height adjustable: 128cm - 143cm [50" - 56"]
- Transparent plastic blade
- Color: Blue or Beige or Red (Vietnam only)

### Specification

Model No.	[V]	•	Consumption [W]	R.P.M. [min <sup>-1</sup> ]	Air Velocity		Air Delivery		Weight [kg]	
					[m/min]	[ft/min]	[m <sup>3</sup> /min]	[ft <sup>3</sup> /min]		
F-409K	50		Hi	45.9 - 56.1	999 - 1221	228	748	63	2,225	9.3
			Lo	35.0 - 42.8	716 - 875					

Note: The value in Specification table are representative characteristics value at 220V, 50Hz. R.P.M. data is for reference only, values may vary subject to different conditions.

## F-409M Wall Fan - Remote Control Type



- Wireless remote controller
- Oscillation control
- Easy angle adjustment
- 3-speed and off electronic switch
- Transparent plastic blade
- Color: Blue or Grey

### Adjustment of Circulation Angle "One-touch" adjustment of tilt

The air flow can be adjusted upward or downward by simply moving the guard up or down as shown in the figure. Adjust the angle of the fan only after first confirming that it has stopped rotating.

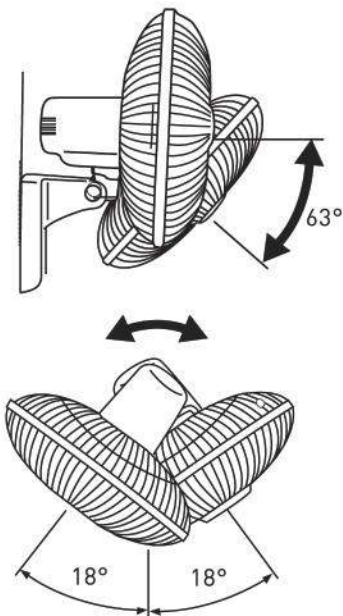

### Double oscillation

To change the direction of the air flow, push the edge of the guard to the desired position.

### Specification

Model No.	[V]	•	Consumption [W]	R.P.M. [min <sup>-1</sup> ]	Air Velocity		Air Delivery		Weight [kg]	
					[m/min]	[ft/min]	[m <sup>3</sup> /min]	[ft <sup>3</sup> /min]		
F-409M	50		Hi	45.8 - 56.1	1059 - 1294	228	748	63	2,225	4.4
			Lo	33.8 - 41.4	765 - 935					

Note: The value in Specification table are representative characteristics value at 220V, 50Hz. R.P.M. data is for reference only, values may vary subject to different conditions.

## F-407W 40cm [16"]



- 3-speed and off push-button switch
- Attractive twin lamps
- Height adjustable: 134cm - 157cm [52<sup>3/4</sup>" - 61<sup>3/4</sup>"]
- Metal blade
- Color: Blue or Gold

### Specification

Model No.	[V]	•	Consumption [W]	R.P.M. [min <sup>-1</sup> ]	Air Velocity		Air Delivery		Weight [kg]	
					[m/min]	[ft/min]	[m <sup>3</sup> /min]	[ft <sup>3</sup> /min]		
F-407W	50		Hi	48.2 - 58.8	1058 - 1293	226	741	63	2,225	9.5
			Lo	40.0 - 48.8	764 - 933					

Note: The value in Specification table are representative characteristics value at 220V, 50Hz. R.P.M. data is for reference only, values may vary subject to different conditions.

## F-308NH/F-307KH 30cm (12")



- 1/f Yuragi function
- 3-speed and electronic ON/OFF switch
- Slim and compact motor design
- 4-hour electronic timer
- Height adjustable: 91cm - 105cm (36" - 41")
- Wireless remote control
- Transparent plastic blade
- Color: Baby Pink or Pastel Blue



Remote Control

### Specification

Model No.	Hz	*	Consumption [W]	R.P.M. [min <sup>-1</sup> ]	Air Velocity [m/min]	Air Delivery		Weight [kg]
						[m <sup>3</sup> /min]	CFM	
F-308NH	50	Hi	34-42	935-1,140	181	40	1,412	4.8
		Lo	19-25	630-800				

Note: All values in specification table are at 220V



- 1/f Yuragi function
- The attached air filter combines Super alleru-buster, Green Tea Catechin and Anti-bacteria Enzyme functions
- 3-speed and electronic ON/OFF switch
- Wireless remote control
- Height adjustable: 66cm - 85cm (26" - 33")
- 4-hour electronic timer
- Transparent plastic blade
- Color: Metallic Green or Silver



Remote Control

### Specification

Model No.	Hz	*	Consumption [W]	R.P.M. [min <sup>-1</sup> ]	Air Velocity [m/min]	Air Delivery		Weight [kg]
						[m <sup>3</sup> /min]	CFM	
F-307KH	50	Hi	44	968-1232	201	51	1,412	4.8
		Lo	25	711-940				

Note: All values in specification table are at 220V

## F-400C 40cm (16")



Beige gray

- 3-speed and push-button switch
- Transparent plastic blade
- Color: Ivory or Beige Gray

### Specification

Model No.	[V]	*	Consumption [W]	R.P.M. [min <sup>-1</sup> ]	Air Velocity		Air Delivery		Weight [kg]
					[m/min]	[ft/min]	[m <sup>3</sup> /min]	[ft <sup>3</sup> /min]	
F-400C	50	Hi	44.0-53.8	1,094-1,337	237	778	65	2,295	4.8
		Lo	54.0-66.0	625-763					

Note: The value in Specification table are representative characteristics value at 220V, 50Hz. R.P.M. data is for reference only, values may vary subject to different conditions.

## VENTILATION PRODUCT SPECIFICATION

	Model No.	Phase		Power Consumption [W]	R.P.M [min <sup>-1</sup> ]	Air Volume		Noise [dB(A)]	Weight [kg]	Duct Size [mm]
						50Hz				
						[CMH]	[CFM]			
Ceiling Mount Type Ventilating Fan	FV-24JR2	1	-	8	-	160	94	31	2.9	Ø100
	FV-24JA2	1	-	8	-	160	94	31	2.9	Ø100
	FV-24CUR1	1	-	11	-	140	82	25	2.8	Ø100
	FV-24CHR1	1	-	17	-	200	118	32	2.8	Ø100
	FV-24CURV1	1	-	11	-	140	82	25	2.9	Ø100
	FV-24CHR1V1	1	-	17	-	200	118	32	2.9	Ø100
	FV-17CU8	1	-	7.5	-	85	50	23	1.7	Ø100
	FV-24CU8	1	-	10.5	-	140	82	25	2.7	Ø100
	FV-24CD8	1	-	13.5	-	170	100	28.5	2.7	Ø100
	FV-24CH8	1	-	16.5	-	200	118	32	2.7	Ø100
	FV-27CH9	1	Hi	28	570	330	194	34	4.4	Ø150
		1	Lo	23	480	260	153	30		
	FV-32CD9	1	Hi	42	590	430	253	36	5.2	Ø150
		1	Lo	32	460	300	177	28		
	FV-32CH9	1	Hi	55	710	530	312	41	5.6	Ø150
		1	Lo	45	570	400	235	34		
	FV-38CD8	1	Hi	90	645	640	377	44	9.7	Ø150
		1	Lo	66	456	430	253	35		
FV-38CH8	1	Hi	122	790	800	471	50	10.4	Ø150	
	1	Lo	89	540	525	309	40			
FV-20CUT1	1	-	22.6	1153	438	258	40.5	1.8	-	
FV-15TGU1	1	-	10	1330	240	141	35	1.2	-	
FV-25TGU5	1	-	26.5	970	612	360	39	1.4	-	
Low Noise Type Cabinet Fan (In-line Fan)	FV-12NS3	1	Hi	18	1265	180	106	21	5.5	Ø100
		1	Lo	17	1020	145	85	17		
	FV-15NS3	1	Hi	33	1270	340	200	25	6.5	Ø150
		1	Lo	29.5	1100	275	162	22		
	FV-18NS3	1	Hi	60	1250	500	294	29	8.5	Ø150
		1	Lo	55	1100	405	238	27		
	FV-18NF3	1	Hi	91	1190	770	453	31	10	Ø200
		1	Lo	80	1000	620	365	29		
	FV-20NS3	1	Hi	120	1195	920	541	32	14	Ø200
		1	Lo	113	1000	720	424	29		
	FV-23NL3	1	Hi	230	1245	1200	706	40	18	Ø200
		1	Lo	170	985	900	530	34		
	FV-25NS3	1	Hi	345	1125	1700	1001	41	24	Ø250
		1	Lo	265	950	1380	812	38		
	FV-25NF3	1	Hi	390	1225	1900	1118	43	24	Ø250
		1	Lo	325	1070	1600	942	40		

# VENTILATION PRODUCT SPECIFICATION

# INSTALLATION METHOD

	Model No.	Phase		Power Consumption [W]	R.P.M [min <sup>-1</sup> ]	Air Volume		Noise [dB(A)]	Weight [kg]	Duct Size [mm]
						50Hz				
						[CMH]	[CFM]			
Industrial Type Ventilating Fan	FV-25GS4	1	-	39	1360	1100	647	34	4.4	-
	FV-30GS4	1	-	59	1360	1800	1059	38	6.1	-
	FV-35GS4	1	-	88	1420	2670	1571	44	10.5	-
	FV-40GS4	1	-	161	1450	3780	2224	47	19	-
	FV-45GS4	3	-	227	1410	5400	3176	51	19	-
	FV-50GS4	3	-	249	960	6130	3608	47	22.5	-
	FV-60GS4	3	-	245	970	8040	4732	50	34	-
	FV-45GT4	1	-	220	1450	5520	3249	52	18.5	-
	FV-50GT4	1	-	320	1400	6960	4097	54	28.5	-
	FV-60GT4	1	-	310	940	9420	5544	49	34	-
Wall Mount Ventilating Fan	FV-10EGS1	1	-	5.5	2706	75	44	33	0.9	Ø120 - Ø125
	FV-15EGS1	1	-	6.2	2329	150	88	36	1.1	Ø165 - Ø170
	FV-10EGF1	1	-	5.5	2706	75	44	31	0.9	Ø135 ± 5
	FV-15EGF1	1	-	6.2	2369	155	91	33	1.1	Ø180 ± 5
	FV-25AUF1	1	-	34	1100	835	491	42	2.8	-
	FV-20AU9	1	-	20	1190	546	321	40	2.2	-
	FV-25AU9	1	-	27	1060	835	491	43	2.7	-
	FV-30AU9	1	-	31	880	1150	676	43	3.1	-
	FV-20AL9	1	-	20	1190	546	321	40	2.2	-
	FV-25AL9	1	-	27	1060	835	491	43	2.7	-
	FV-30AL7	1	-	31	880	930	547	43	3.1	-
	FV-20RL7	1	Exhaust	20	1240	546	321	39	2.4	-
		1	Intake	15	1190	370	218	46		-
	FV-25RL7	1	Exhaust	29	1100	840	494	43	2.7	-
		1	Intake	21	1035	580	341	45		-
	FV-30RL6	1	Exhaust	31	890	990	583	44	3.1	-
1		Intake	25	770	600	353	43	-		
FV-15AUL1	1	-	12.5	1450	255	150	36	1.2	-	
FV-10BAT1	1	-	15	1250	80	47	40	1.7	-	

## Ceiling Mount Type Ventilating Fan - Applicable Models:

FV-24CUR1 / FV-24CHR1 / FV-24CURV1 / FV-24CHR1 / FV-17CU8 / FV-24CU8 / FV-24CD8 / FV-24CH8 / FV-27CH9 / FV-32CD9 / FV-32CH9

### 1A Installation with anchor bolts

1. Secure the 1 set of suspension bracket (optional accessory) with screws.

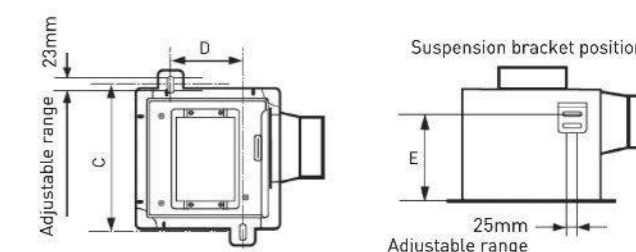
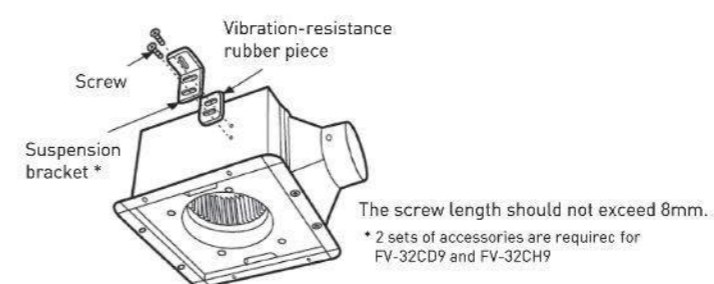

2. Mount the fan body enclosure on the anchor bolts (M8-M10, not supplied).

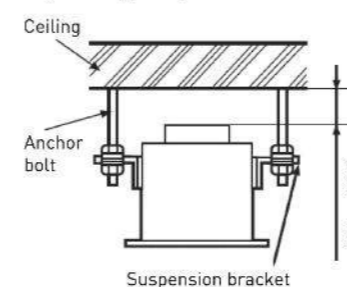

Model No.	C	D	E
FV-24CUR1/FV-24CHR1	266mm	131mm	112mm
FV-24CURV1/FV-24CHR1	266mm	131mm	112mm
FV-17CU8	206mm	89mm	103mm
FV-24CU8/ FV-24CD8/ FV-24CH8	266mm	131mm	112mm
FV-27CH9	296mm	160mm	158.5mm
FV-32CD9/ FV-32CH9	346mm	200mm	158.5mm

### 1B Installation of adaptor assembly first

1. First remove the hexagon screw attaching the adaptor assembly to the fan body.



2. Build a wooden frame horizontally from the keel. Note that the distance between the top of the fan body and the ceiling should be at least 20mm.

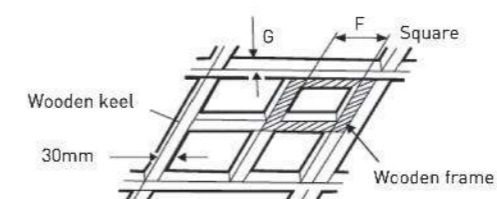

Model No.	F	G
FV-24CUR1/FV-24CHR1	240 ± 2	25-30mm
FV-24CURV1/FV-24CHR1	240 ± 2	25-30mm
FV-17CU8	177 ± 2	25-30mm
FV-24CU8/ FV-24CD8/ FV-24CH8	240 ± 2	25-30mm
FV-27CH9	270 ± 2	25-30mm
FV-32CD9/ FV-32CH9	320 ± 2	25-30mm

\* Ceiling joist must be subject to static load more than 5 times of the product weight.

## Ceiling Mount Type Ventilating Fan - Applicable Models

3. Attach the adaptor assembly to the wooden frame as shown in the figure.

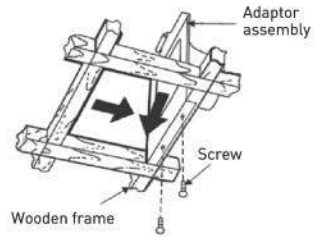

4. Insert the fan body in the wooden frame, and connect it to the adaptor assembly.

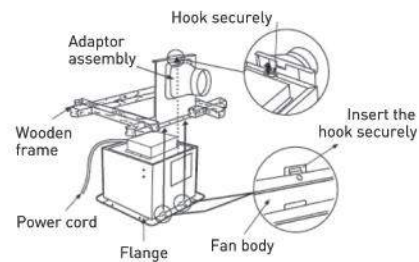

5. Firmly secure the fan body with four tapping screws and a hexagon screw.

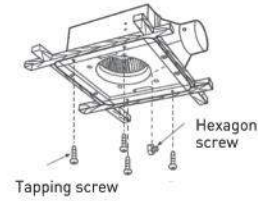

### 2 Power cord connection

Connect the power cord to the power supply line according to the wiring diagram and the local electrical wiring rules of fixed wiring.

Make sure all connections are fastened firmly after wiring is finished.

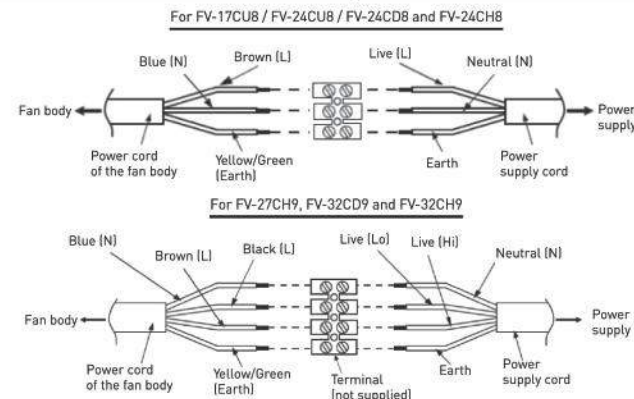

### 3 Duct connection and ceiling plate installation

1. Insert the duct into the adaptor assembly, and tighten it with adhesive tape (not supplied). (Suspend the duct from the ceiling to prevent any external force onto the fan body)

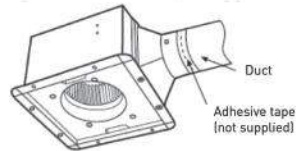

2. Install the ceiling plate. Note that the gap between the flange and the ceiling plate should be 2 to 3mm.

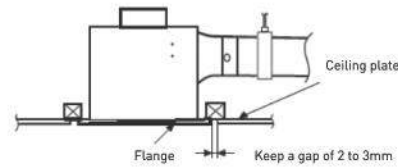

3. Install the pipe hood or vent cap (optional accessories) on the outer wall.

	Pipe Hood	Vent Cap
FV-17CU8 / FV-24CU8 / FV-24CD8 / FV-24CH8	FV-MCX100P	FV-VCX100P
FV-27CH9 / FV-32CD9 / FV-32CH9	FV-MCX150P	FV-VCX150P

Slope the duct downward and guide it through the wall to the outside. Be sure to prevent rainwater from falling in the duct from its outlet. (The minimum size of the hole opening on the wall is:  $\varnothing 116\text{mm}$  for 17/24 models,  $\varnothing 168\text{mm}$  for 27/32 model)

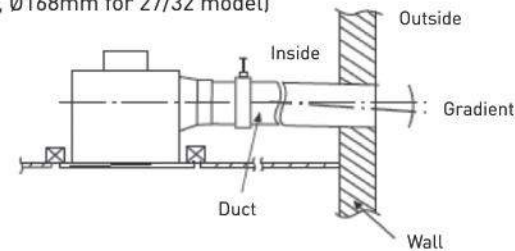

### 4 Test run and louver installation

1. When the power is turned on, check for malfunctions as follow:  
Does the fan rotate correctly?  
Does the fan rotate anti-clockwise?  
Is there any abnormal sound or vibration?

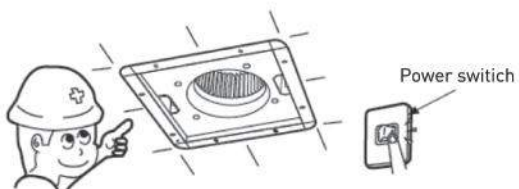

2. Insert the mounting spring into the slots and mount the louver to the fan body. (Please wear gloves during installation)

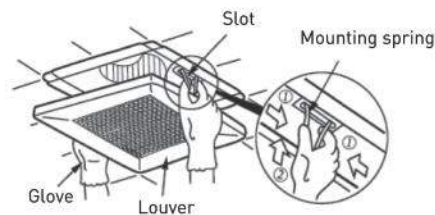

## Low Noise Type Cabinet Fan (In-line Fan)

Applicable Models - FV-12NS3 / FV-15NS3 / FV-18NS3 / FV-18NF3 / FV-20NS3 / FV-23NL3 / FV-25NS3 / FV-25NF3

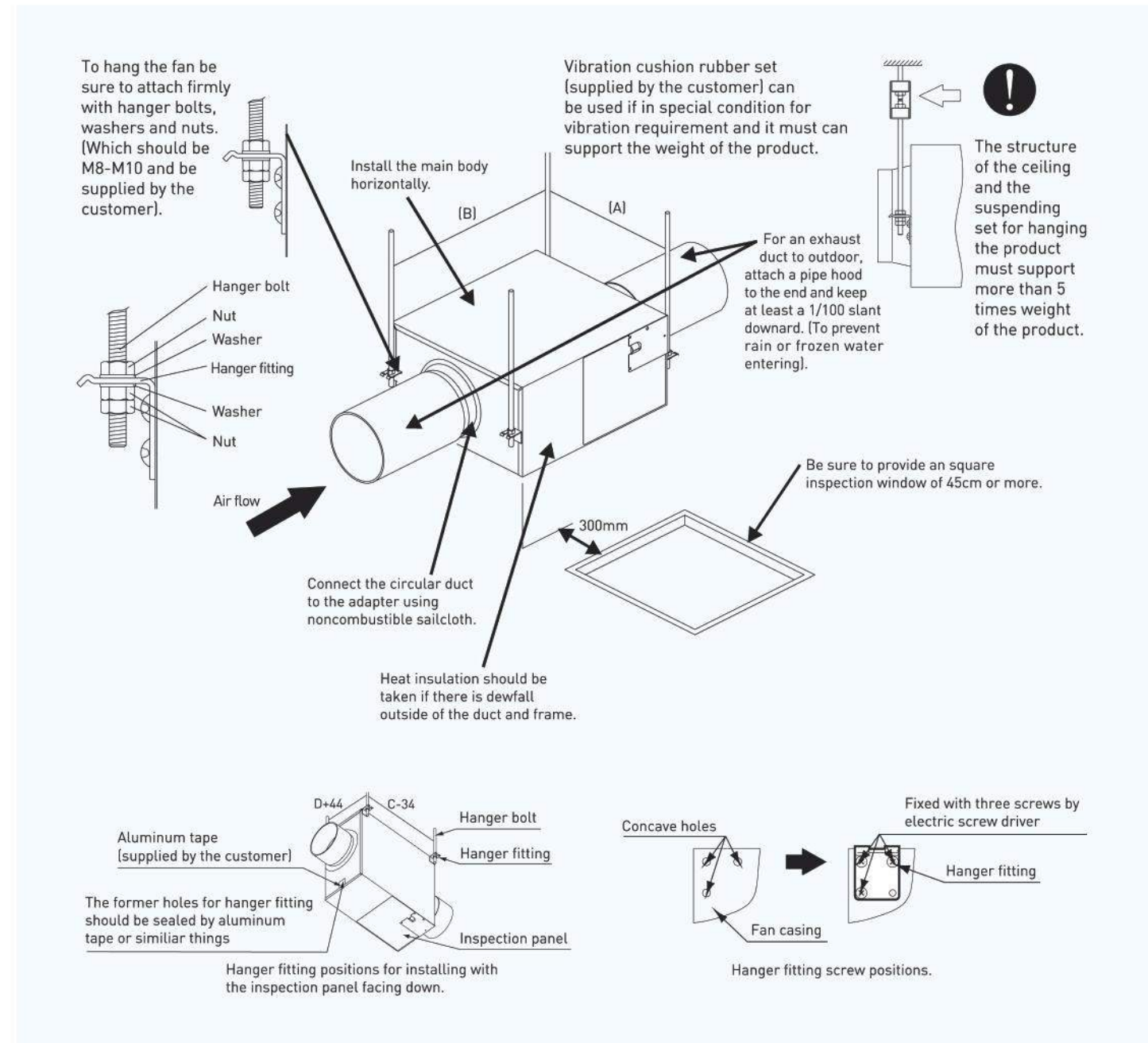

Notes:

To install the fan with the inspection panel facing down, remove the attached four hanger fittings and re-attach them in the holes on the top and bottom surfaces (use the screws you just removed). The former holes for installing the hanger fitting need to be sealed.

Model No.	A	B	C	D
FV-12NS3	250	335	291	184
FV-15NS3	250	346	302	206
FV-18NS3	276	382	338	232
FV-18NF3	336	441	397	254
FV-20NS3	376	485	441	272
FV-23NL3	424	513	469	298
FV-25NS3	450	549	505	334
FV-25NF3	450	549	505	334

Unit: mm



## Wall Mount Type Ventilating Fan

Applicable Models - FV-20AU9 / FV-25AU9 / FV-30AU9 / FV-20AL9 / FV-25AL9 / FV-30AL7  
FV-20RL7 / FV-25RL7 / FV-30RL6

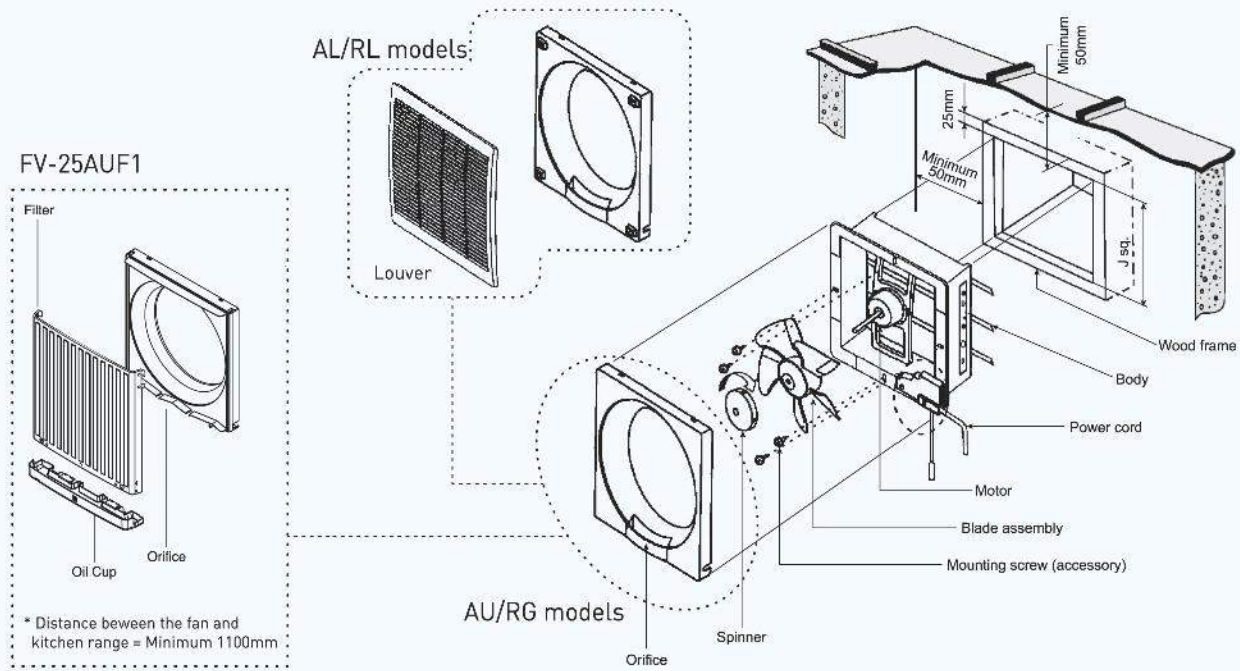

## Wiring Diagram

Connect the power cord to the power supply line according to the wiring diagram and the local electrical wiring rules of fixed wiring.

- Make sure all connections are fastened firmly after wiring is finished.
- It is required to use terminal [not included] that complies IEC 60998.

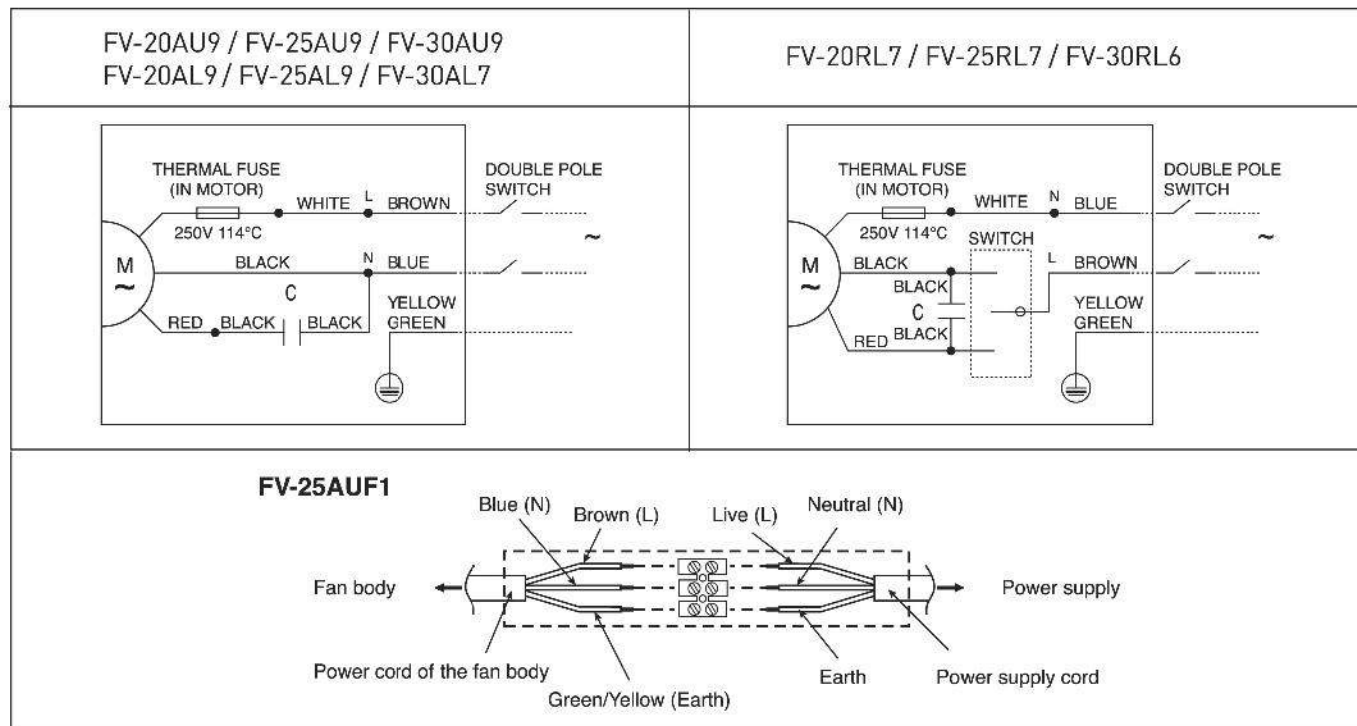

## Ceiling Fan

Applicable Models - F-60WWK

- Remove the supplied bolt, nut, cotter pin and pulley at the top. Place the pulley onto the ceiling hook.
- Remove the spring washer and safety wire screw from the pipe. Arrange and tie the safety wire as shown.
- Firmly screw the safety wire onto the pipe.
- Connect the wires to the house supply line according to diagram shown. Pull the wires after fixing to ensure the wires are tighten firmly.
 

The length of the external earthing conductor which should be such that when failure of the system occur, the current-carrying conductors taut before the earthing conductor.
- Before proceed to Step A, remove the screws from the canopy.
 

Step A : Take the canopy (2pcs) and press (until "click" sound is heard) it as shown.

Step B : Fix the screws into the canopy and tighten it.

Step C : Separate the canopy plate set as shown in picture.

Step D : Take the canopy plate (2pcs) and clip it as shown.
- Hook the blades on the motor and tighten with the blade screws.
- Fix the decoration cap at the motor.

# Ceiling Fan

## Applicable Models - Regulator Control Series

### A Assemble Pipe To Motor Assembly

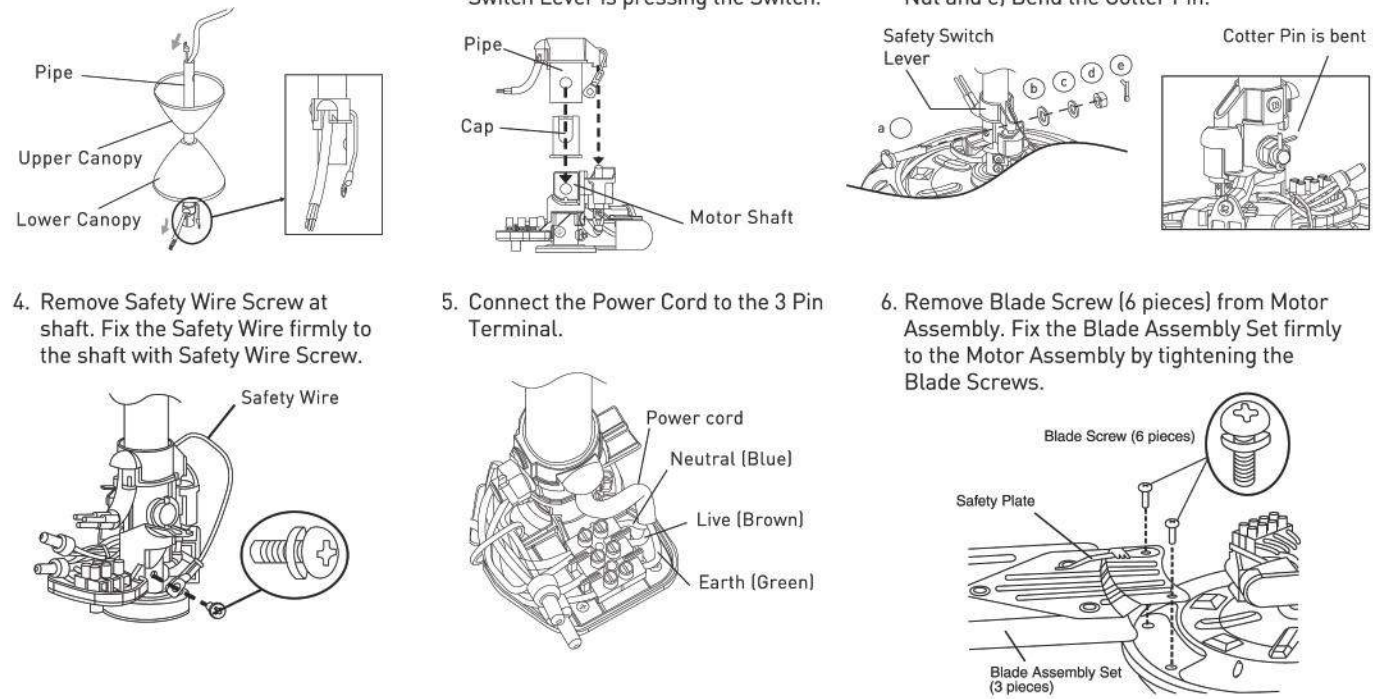
1. Pull power cord (from power supply) and insert into the Pipe hole.
  2. Insert the Cap to the Motor Shaft, fix the Pipe to Motor Shaft and ensure the Switch Lever is pressing the Switch.
  3. Fix the Pipe and Motor Assembly with a) Ellipse Bolt, b) P-R Washer, c) Spring Washer, d) Hexa Nut and e) Bend the Cotter Pin.
  4. Remove Safety Wire Screw at shaft. Fix the Safety Wire firmly to the shaft with Safety Wire Screw.
  5. Connect the Power Cord to the 3 Pin Terminal.
  6. Remove Blade Screw (6 pieces) from Motor Assembly. Fix the Blade Assembly Set firmly to the Motor Assembly by tightening the Blade Screws.
- 

### B Installation to Ceiling

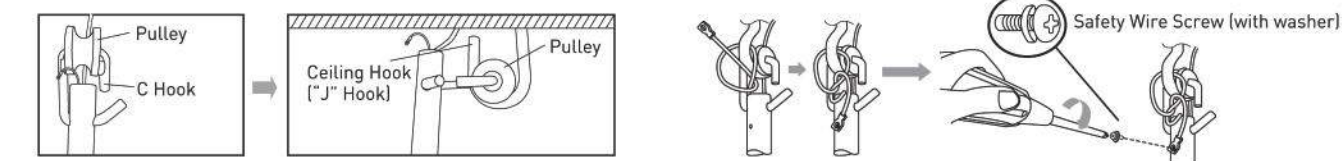
1. Cross C Hook of Pulley Set to the Pipe and place the Pulley on Ceiling Hook.
  2. Loop the Safety Wire to the Ceiling Hook and screw it to the Pipe with Safety Wire Screw.
- 

### C Fix the Canopy

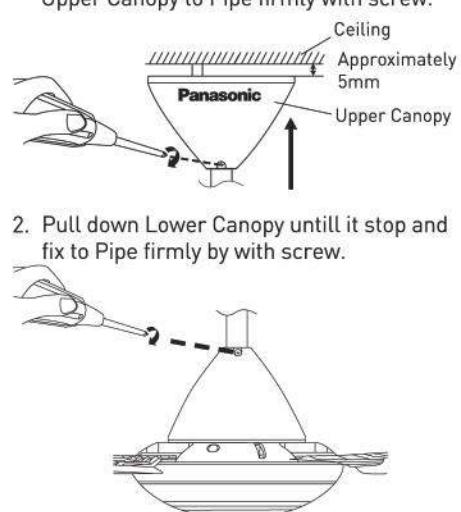
1. Adjust Upper Canopy position and fix Upper Canopy to Pipe firmly with screw.
  2. Pull down Lower Canopy until it stop and fix to Pipe firmly by with screw.
- 

### D Installation of Speed Regulator

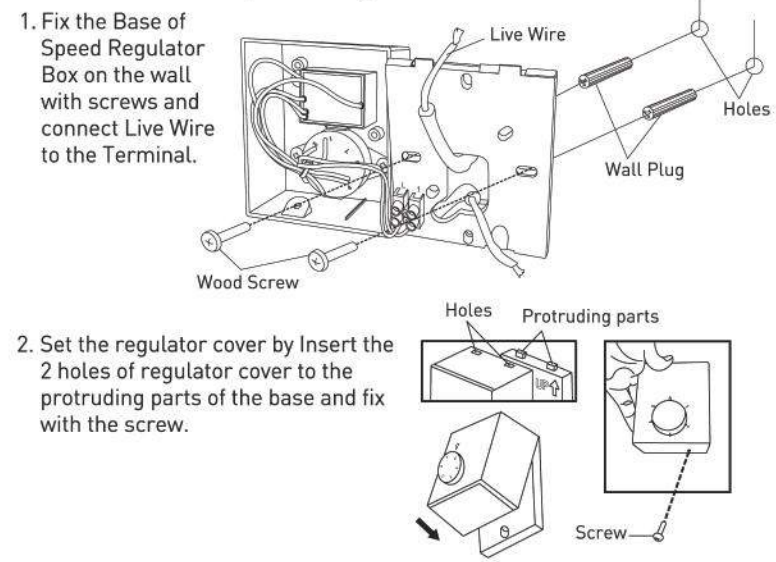
1. Fix the Base of Speed Regulator Box on the wall with screws and connect Live Wire to the Terminal.
  2. Set the regulator cover by Insert the 2 holes of regulator cover to the protruding parts of the base and fix with the screw.
- 



# AIR PURIFIER

## Air Purifier Provide Clean And Fresh Air For You And Your Family

1. **nanoe™**  
Provide your healthy and maintenance your beauty with the unique technology
2. **ECONAVI**  
Eco operation mode that runs only as it is necessary
3. **HEPA Composite Filter**  
Anti-bacteria Enzyme, Green tea Catechin, Super alleru-buster  
HEPA Composite Filter not only can remove 0.3um particles, it also consists of 3 kinds of technology, Super alleru-buster, Green tea Catechin and Anti- bacteria enzyme. It can inhabit 17 kinds of virus, bacteria and allergen up to 99%

## Specification

	F-PXM55A	F-PXM35A	F-PXJ30A	F-P15EHA
Style				
Color	Gold	Silver and Blue	White	White
Applicable area	42	26	20	13
<b>Air Purifying</b>				
Air Volume (Hi / Mid / Low)	5.3 / 2.0 / 0.9	3.5 / 2.0 / 1.0	2.8 / 1.8 / 0.8	1.6 / 1.2 / 0.8
Power Consumption (Hi / Mid / Low)	49 / 11 / 7	24 / 9 / 6	30 / 22 / 15	29 / 22 / 18
Noise (Hi / Mid / Low)	52 / 32 / 18	44 / 32 / 18	44 / 35 / 21	44 / 40 / 32
Dust Filter (Lifetime)	HEPA Composite Filter	HEPA Composite Filter	Composite Filter	HEPA Dust Collection Filter
Deodorizing Filter (Lifetime)	(10Y)	(3Y)	(2Y)	(2Y)
Filter Replace Indicator/ Filter Life Check	•	•	•	•
Motor Type	DC	DC	AC	AC
3D Circulation Airflow	•	•	•	•
ECONAVI	•	-	-	-
Auto Mode	•	•	•	-
Turbo Mode	PM2.5	•	•	-
Sleep Mode (8 hours)	•	•	•	-
Spot Air Mode	-	-	-	-
Sensor	Dirt/Odor/Light	Odor	Odor	-
Clean Sign	•	•	•	-
PM2.5 Indicator	•	-	-	-
Child Lock	•	-	-	•
Brightness Control	-	-	-	-
Dimension (H x W x D)	580 x 300 x 205	520 x 300 x 189	540 x 311 x 210	385 x 310 x 185
Weight (Kg)	5.8	4.8	4.3	3.5
<b>Air Purifying &amp; Humidity</b>				
Humidity Capacity	-	-	-	-
Air Volume (Hi / Mid / Low)	-	-	-	-
Power Consumption (Hi / Mid / Low)	-	-	-	-
Noise (Hi / Mid / Low)	-	-	-	-
Humidity Filter (Lifetime)	-	-	-	-

# PURIFYING INDOOR AIR

## air-e ceiling mount nanoe™ generator



Deodorize

Inhibits Bacteria, Viruses, Mold & Allergens

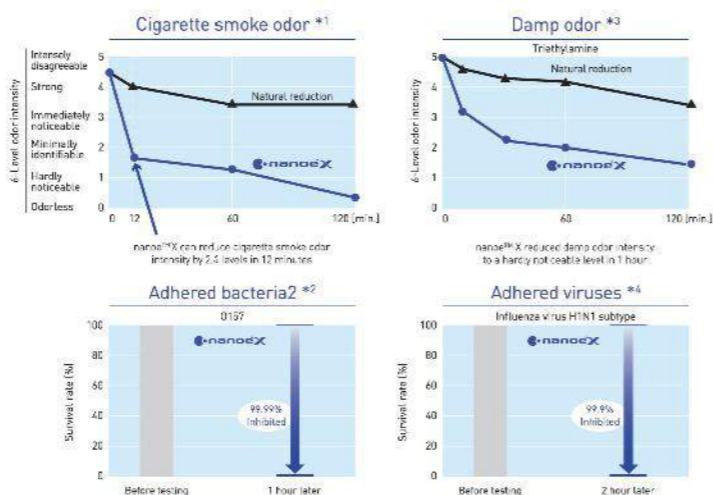
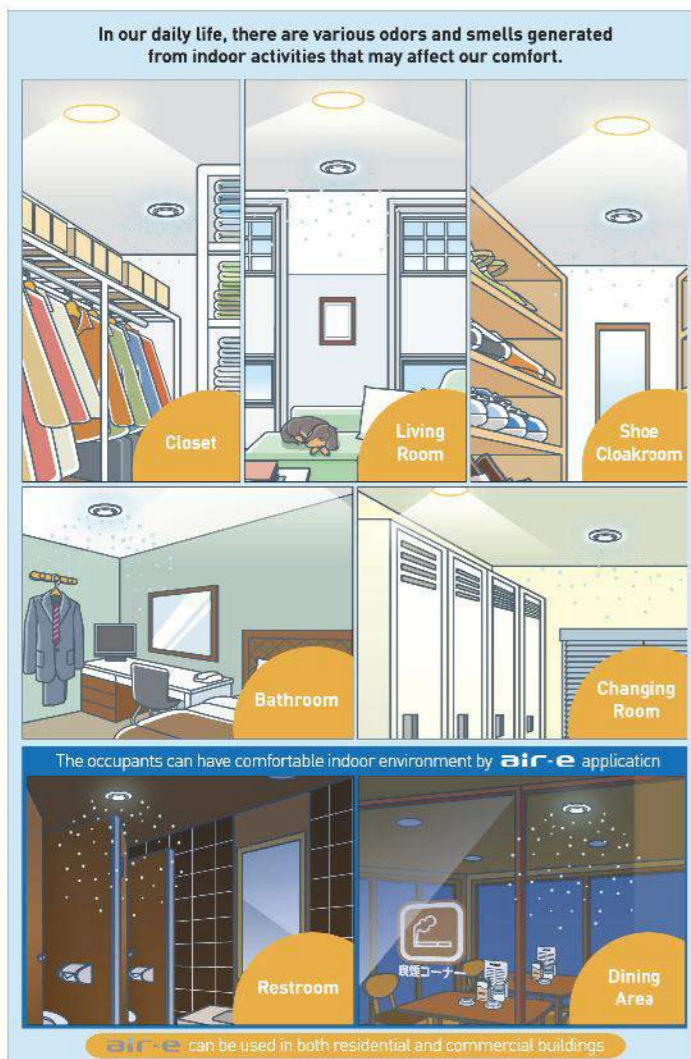

(\*1) (Testing organization) Panasonic Product Analysis Center (Testing method) Verified using the six-level odor intensity scale method in an approximately 23m<sup>2</sup> sized test room. (Deodorization method) nanoe™ released (Test substance) Surface-attached cigarette smoke odor (Test result) Odor intensity reduced by 2.4 levels in 12mins. (AA33-1604'5-N04).

(\*2) (Adhered bacteria) (0157) (Testing organization) Japan Food Research Laboratories (Testing method) Measured the number of bacteria adhered to a cloth in an approximately 45L sized airtight test room. (Inhibition method) nanoe™ released (Test substance) Adhered bacteria (Test result) Inhibited by at least 99.99% in 1 hour. (208120880\_001).

(\*3) (Testing organization) Panasonic Product Analysis Center (Testing method) Verified using the six-level odor intensity scale method in an approximately 23m<sup>2</sup> sized test room. (Deodorization method) nanoe™ released (Test substance) Surface-attached damp odor (Test result) Odor intensity reduced by 1.7 levels in 0.5 hours. (Y16RA002).

(\*4) (Adhered virus) (Influenza virus H1N1 subtype) (Testing organization) Kitazato Research Center for Environmental Science (Testing method) Measured the number of virus adhered to a cloth in an approximately 1m<sup>2</sup> sized airtight test room. (Inhibition method) nanoe™ released (Test substance) Adhered virus (Test result) Inhibited by at least 99.99% in 2 hours. (21\_0084\_1).

Disclaimer: Data provided regarding the effectiveness of nanoe™ X and nanoe™ have been obtained through experiments under special conditions using devices which generate electrostatic atomized water, and have not been tested through commercial products with the devices incorporated in them.

Deodorization effect varies according to the environment (temperature and humidity), operation time, odor, and fabric types. It does not eliminate toxic substances in cigarettes (carbon monoxide, etc.). Odors that are continuously generated (e.g. building material odors and pet odors) are not completely eliminated. Results may vary based on usage, and seasonal/ environmental variables (temperature and humidity). nanoe™ X and nanoe™ inhibit activity or growth of viruses, but do not prevent infection.

Individual results may vary based on usage, and environmental variables (temperature and humidity).

### ● Main Dimension (Unit: mm)

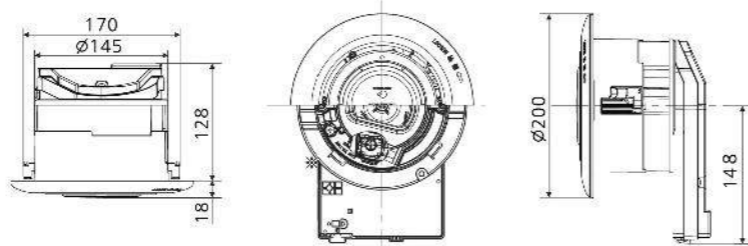

Model No	Rated Voltage [V]	Rated Frequency [Hz]	Power Consumption [W]	Air Volume [m <sup>3</sup> /min]	Noise [dB]	Net Weight [kg]
FV-15CSD1	220	50	4	15	23.5	1.1

1. The value of air volume, power consumption and noise are specified at the static pressure of 0Pa.  
 2. The value of air volume is the mean value and a tolerance of ± 10% is allowed.  
 3. The value of noise level is A weight average sound pressure level, the mean value is measured by our company. A tolerance of +3dB/-7dB is allowed. The noise is measured at 1m apart from the left, the front and the below of the product.

## F-PXU70A



### Air Purification

- nanoe™
- HEPA Composite Filter
- Super Nano-technology Deodorizing Filter
- De-Formaldehyde Function

### Indicator

- LCD Indication Panel
- PM2.5 Concentration Digital Indicator
- Odor Level Indicator
- Filter Replacement Indicator

### Other Features

- PM2.5 / Odor Sensor
- Brightness Sensor
- Child Lock

### Specifications

Setting	Air Purification		
	High	Mid	Low
Power Consumption [W]	36	10.5	6.5
Air Volume [m <sup>3</sup> /min.]	7	3.1	1.1
Noise [dB(A)]	48	32	18

Applicable Area	Weight
52 m <sup>2</sup> (560 ft <sup>2</sup> )	8 kg
Dimension	
H 560 x W 362 x D 280 mm	

## F-PXV50A



### Air Purification

- nanoe™ technology
- 2 in 1 HEPA composite and deodorizing filter

### Special Feature

- Manual brightness adjustment
- Direct Current (DC) motor
- Seamless drive
- Auto mode

### Smart Sensing

- Dirt sensor equipped

### Air Flow

- Direct front suction
- House dust catcher
- 3D circulation airflow

### Indication

- Clean sign
- PM2.5 Indicator
- Filter replace indicator

### Specifications

	Air Purifying		
	High	Medium	Low
Air Volume [m <sup>3</sup> /min]	5.0	2.5	1.1
Power Consumption [W]	29	10	6.0
Noise [dB(A)]	47	33	19

Applicable Area	Weight
36 m <sup>2</sup> (388 ft <sup>2</sup> )	16.2 kg
Dimension	
H 550 x W 340 x D 208 mm	

## F-VXV70A



### Air Purification

- nanoe™X
- HEPA Composite Filter
- Super Nano-technology deodorizing Filter
- Large particle pre-filter

### Special Feature

- Twin airflow louver
- Spot air mode
- 3-level humidity setting
- Direct Current (DC) motor
- Seamless drive
- Child lock
- Tank stand
- Caster lock

### Smart Sensing

- Dirt / Odor / Humidity sensor equipped
- Human activity sensor
- Light sensor

### Air Flow

- Direct front suction
- Mega catcher
- 3D circulation airflow

### Indication

- Clean sign
- 5-level humidity indicator
- Filter replace indicator

### Specifications

	Air Purifying			Air Purifying & Humidifying		
	High	Medium	Low	High	Medium	Low
Humidifying Capacity [mL/h]	-	-	-	700	400	250
Air Volume [m³/min]	6.7	2.7	1.1	6.3	3.1	1.9
Power Consumption [W]	66	11	6.0	58	15	10
Noise [dB(A)]	54	33	18	53	36	25

Applicable Area	Tank Capacity
52 m <sup>2</sup> (560 ft <sup>2</sup> )	3.5L
Dimension	Weight
H 636 x W 398 x D 265 mm	10.2 kg

## F-GPT01A



### Convenient Connection

nanoe™X Generator can be used conveniently with USB charging ports, laptops, computers and power bank

### Portable & Lightweight

Comes in the compact size of a coffee tumbler, nanoe™X Generator makes it perfect for various environment without taking up much space. With the weight of only 0.4kg, it is easy to carry around.

### Easy Operation

Clean air on your fingertips. nanoe™X will be released by simply pressing the power button on top of nanoe™X Generator.

### Specification

Model	Estimated Applicable Volume*9	Air Volume	Noise	Consumption	Power Cord	Voltage	Dimension	Weight	Color
F-GPT01A	3m <sup>3</sup>	0.07m <sup>3</sup> /min	34dB	3.5W	1.5m Type C USB	DC 5V (Adaptor 1.5A above)	170 x 90 x 66 mm (H) (Top) (Base)	0.4kg	Black/Red

## DEHUMIDIFIER



### Auto mode

Humidity sensor detects the ambient level of humidity and keeps indoor humidity at the most suitable level for the human body.



### Cont./Laundry mode

The machine works with a high capacity to quickly reduce the humidity. This mode is especially useful in drying clothes, making laundry in the rainy season no longer a worry.



### Fan mode

The machine works with a small capacity, help to remove dust in the air and minimize tobacco smoke.



Model No.	F-YCT10V	FYCT14V	F-YCT17V
Usable area (m <sup>2</sup> )	25	35	42
Dehumidification capacity (L/day)	10	14	17
Tank volume (L)	2.5	2.5	4.8
Power consumption (W)	220	230	285
4 in 1 filter	-	0	0
Auto mode	0	0	0
Continuous dehumidification mode	0	0	0
Fan mode	-	0	0
Humidity sensor	0	0	0
Timer	-	0	0
Dimension (L x W x H)(mm)	530X293X230	580X300X215	605X360X260
Weight (kg)	13	11.5	14

# ziaino™ Air Treatment Unit

## F-JPU70A

- 3-speed selection
- 3 level of electrolysis intensity
- Safety lock / indicator
- Brightness Off/On button
- Salt input confirm button to avoid negligence
- Clear status indicator at front display
- Alert indicator (door, water refill, drain, salt input)
- Dimension: 730 (H) x 510 (W) x 307 (L)
- Weight: 17 Kg



## Specifications

Model		Air Volume		Consumption	Noise	Continuous Operation Time with Full Water
		[m/min]	[CFM]			
F-JPU70A	Hi	7.0	247	72	49	9.6
	Med	4.0	141	31	37	14
	Lo	2.0	70	20	20	22.6



### Compact and Energy Efficient

- Pump cover with smooth curve for elegant outlook.
- Brass-made casing cover and impeller are resistant to friction and high temperature that allow smoother water stream.

### Reliable and Safe

- Equipped with Thermal Protector (130°C) enhances security against burning by turning off the pump directly as temperature exceeds the limit.
- Double stator protection being resistant to abrasion reduce the danger of short circuit.

### Durable

- High accurate rotor with anti-rust layer allows operation up to 8,000 hours without stopping.
- Stainless aluminum motor body and brass casing cover allow high durability.

### Structure (For Auto Series) (\*)

- Accumulator is a compression space containing Nitrogen Gas which has characteristics of elasticity. The gas content will never deplete that always stay stable and optimum.
- Rubber Bladder is made of Butyl that is stainless and anti-leakage. It functions as water separator with the Nitrogen compression room.
- Automatic Switch equipped with a protector made of fire-retardant material and a Platinum-made Switch that is long-lasting. It functions to break the stream if the water stream is closed.

(\*) Except A-130JTX

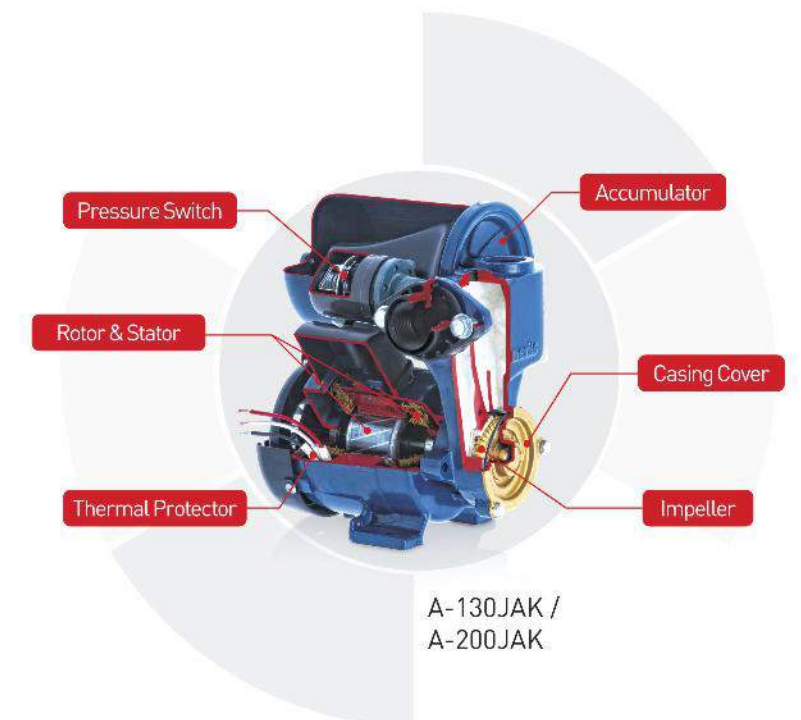

## Flow Switch Booster (Shallow Well Type)



GA-125FAK

### Specification

Model No.	GA-125FAK
Power consumption (W)	125
Capacity (L/min)	30
Suction Head (m)	-
TTL Head (m)	27
Switch On Pressure (kgf/cm <sup>2</sup> )	-
Switch Off Pressure (kgf/cm <sup>2</sup> )	-
Suction pipe [inch (mm)]	1 (25)
Push pipe [inch (mm)]	1 (25)
Dimension [(L x W x H) (mm)]	202 x 150 x 198
Weight (kg)	4.8

## Non-Auto Series (Shallow Well Type)

Compact-size and high performance of Non-auto Series allow easy installation and maintenance in different applications.



Model No.	GP-129JXK	GP-200JXK	GP-250JXK	GP-350JA
Power consumption (W)	125	200	250	350
Capacity (L/min)	30	45	50	45
Suction Head (m)	9	9	9	9
TTL Head (m)	30	30	38	45
Switch On Pressure (kgf/cm <sup>2</sup> )	-	-	-	-
Switch Off Pressure (kgf/cm <sup>2</sup> )	-	-	-	-
Suction pipe [inch (mm)]	1 (25)	1 (25)	1 (25)	1 (25)
Push pipe [inch (mm)]	1 (25)	1 (25)	1 (25)	1 (25)
Dimension [(L x W x H) (mm)]	206 x 152 x 212	225 x 182 x 215	233 x 168 x 236	253 x 170 x 258
Weight (kg)	5.4	7.0	8.0	13.5

## Auto Series (Shallow Well Type)



With Auto Series water pump, flow of water can be controlled by the automatic switch associated with water tap operation, that provides greater convenience.



Model No.	A-130JTX	A-130JACK	A-130JAK	A-200JAK
Power consumption (W)	125	125	125	200
Capacity (L/min)	30	30	32	45
Suction Head (m)	9	9	9	9
TTL Head (m)	25	27	27	27
Switch On Pressure (kgf/cm <sup>2</sup> )	1.0	1.1	1.1	1.1
Switch Off Pressure (kgf/cm <sup>2</sup> )	1.6	1.8	1.8	1.8
Suction pipe [inch (mm)]	3/4 (19)	1 (25)	1 (25)	1 (25)
Push pipe [inch (mm)]	3/4 (19)	1 (25)	1 (25)	1 (25)
Dimension [(L x W x H) (mm)]	Ø300 x 425	330 x 255 x 340	246 x 225 x 240	257 x 238 x 245
Weight (kg)	13	8.8	6.4	7.8

## Centrifugal Type (Shallow Well Type)



Model No.	GP-10HCN1SVN	GP-15HCN1SVN	GP-20HCN1SVN
Maximum Capacity (L/min)	10-99	30-145	30-154
Suction Head (m)	9	9	9
TTL Head (m)	34-25	38.7-22	46.2-26
Input power (kW)	1.16	1.66	2.22
Output power (kW)	0.75	1.1	1.5
IP Rating	IP54	IP54	IP54
Suction pipe [inch (mm)]	1 (25)	1-1/4 (32)	1-1/4 (32)
Push pipe [inch (mm)]	1 (25)	1 (25)	1 (25)
Dimension [(L x W x H) (mm)]	299 x 196 x 246	336 x 210 x 258	363 x 242 x 290
Weight (kg)	15	20	25

# ELECTRICAL CONSTRUCTION MATERIALS

## WIRING DEVICES

Item No.	Page
<b>EBG</b>	
EBG888	29,34,43
<b>EGG</b>	
EGG331	29,34,43
EGG335	29,34,43
<b>NR</b>	
NR3170W-8	49
<b>NRV</b>	
NRV3160W	49
<b>WA</b>	
WA1215	54
WA1219	54
WA1220	54
WA1229	54
WA1315	54
WA1319	54
WA1320	54
WA1329	54
WA1415	54
WA1419	54
WA1420	54
WA1429	54
WA1515	54
WA1519	54
WA1615	54
WA1619	54
WA3215K	54
WA3219K	54
WA3220	54
WA3229	54
WA3230	54
WA3239	54
WA3315	54
WA3319	54
WA3320	54
WA3329	54
WA3330	54
WA3339	54
WA3415	54
WA3419	54
WA3420K	54
WA3429K	54

WA3430	54
WA3439	54
WA35159	54
WA3519K	54
WA3615	54
WA3619	54
WA3630	54
WA3639	54
WA5215K	52
WA5219K	52
WA5220K	52
WA5229K	52
WA5315K	52
WA5319K	52
WA5320K	52
WA5329K	52
WA5330	52
WA5331	52
WA5338	52
WA5339	52
WA5360	52
WA5369	52
WA5420K	52
WA5429K	52
WA5430	52
WA5439	52
WA5460	52
WA5469	52
WA5520	52
WA5529	52
<b>WBC</b>	
WBC8981SW-VN	21,37
WBC8991W-VN	21,37
<b>WBG</b>	
WBG5414699W	48
WBG5414699W-SP	48
<b>WEB</b>	
WEB7811MA	39
WEB7811MB	39
WEB7811MF	39
WEB7811MH	39
WEB7811MW	36,39
WEB7811MWZ	39
WEB7811MY	39
WEB7811SW	36,37,39
WEB7812MA	39
WEB7812MB	39
WEB7812MF	39
WEB7812MH	39
WEB7812MW	36,39
WEB7812MWZ	39
WEB7812MY	39
WEB7812SW	36,37,39
WEB7813MA	39

WEB7813MB	39
WEB7813MF	39
WEB7813MH	39
WEB7813MW	36,39
WEB7813MWZ	39
WEB7813MY	39
WEB7813SW	36,37,39
<b>WEBFP</b>	
WEBFP57311W-VN	37,73
<b>WEBP</b>	
WEBP1041SW-P	37
WEBP515117MA	38
WEBP515117MB	38
WEBP515117MF	38
WEBP515117MH	38
WEBP515117MW	38
WEBP515117MWZ	38
WEBP515117MY	38
WEBP515117SW	38
WEBP515127MA	38
WEBP515127MB	38
WEBP515127MF	38
WEBP515127MH	38
WEBP515127MW	38
WEBP515127MWZ	38
WEBP515127MY	38
WEBP515127SW	38
WEBP525217MA	38
WEBP525217MB	38
WEBP525217MF	38
WEBP525217MH	38
WEBP525217MW	38
WEBP525217MWZ	38
WEBP525217MY	38
WEBP525217SW	38
WEBP525227MA	38
WEBP525227MB	38
WEBP525227MF	38
WEBP525227MH	38
WEBP525227MW	38
WEBP525227MWZ	38
WEBP525227MY	38
WEBP525227SW	38
WEBP535317MA	38
WEBP535317MB	38
WEBP535317MF	38
WEBP535317MH	38
WEBP535317MW	38
WEBP535317MWZ	38
WEBP535317MY	38
WEBP535317SW	38
WEBP535327MA	38
WEBP535327MB	38
WEBP535327MF	38

Item No.	Page
WEBP535327MH	38
WEBP535327MW	38
WEBP535327MWZ	38
WEBP535327MY	38
WEBP535327SW	38
<b>WEC</b>	
WEC5542-7SW	32
WEC5781MYH-VN	20
WEC5781MYZ-VN	19
WEC5781W-VN	18,44
<b>WEF</b>	
WEF11721H8	34,43
WEF11721W8	25,34,43
WEF11821H	43
WEF11821W	25,43
WEF5791301H-VN	34,44
WEF5791301SW-VN	25,34,44
WEF5791501H-VN	34,44
WEF5791501SW-VN	25,34,44
<b>WEG</b>	
WEG1001H	34,43
WEG1001SW	34,43
WEG1090H	34,43
WEG1090SW	34,43
WEG1181BK-G	28
WEG15829B-G	28
WEG3020B-G	28
WEG3020H	42
WEG3020SW	25,42
WEG3023H	42
WEG3023SW	25,42
WEG3032G-031	44
WEG3032GH	42
WEG3032GSW	42
WEG3032R-021	44
WEG3032RH	42
WEG3032RSW	42
WEG3032SW	42
WEG3032WH	42
WEG5001SWK-031	44
WEG5002SWK-021	44
WEG5003KH	42
WEG5003KSW	42
WEG5004KH	42
WEG5004KSW	42
WEG5141H	42
WEG5141SW	42
WEG5151-51HK	36,42
WEG5151-51SWK	37,42
WEG51517H	42
WEG51517SW	42
WEG5152-51HK	42
WEG5152-51SWK	42

WEG51527H	42
WEG51527SW	42
WEG5341H	42
WEG5341SW	42
WEG5400-7	42
WEG5401-011SW	44
WEG5401-7H	43
WEG5401-7SW	37,43
WEG5511-MH	32
WEG5512-MH	32
WEG5521-MH	32
WEG5522-MH	32
WEG5531-MH	32
WEG5532-MH	32
WEG5551-MH	32
WEG5552-MH	32
WEG5561-MH	32
WEG5562-MH	32
WEG5571-MH	32
WEG5572-MH	32
WEG575151H	44
WEG575151SW	25,44
WEG575181	37,44
WEG575181H	36,44
WEG57813B-1-G	29
WEG57816B-1-G	29
WEG57912B-1	29
WEG57912H	34,44
WEG57912SW	25,34,44
WEG6501-1	45
WEG6502-1	45
WEG65029-1	45
WEG6503-1	45
WEG6591-1	45
WEG6601-1	45
WEG6602-1	45
WEG66029-1	45
WEG6603-1	45
WEG6691-1	45
WEG68010MA	35,45
WEG68010MF	35,45
WEG68010MWZ	35,45
WEG68010MY	35,45
WEG68020MA	35,45
WEG68020MF	35,45
WEG68020MWZ	35,45
WEG68020MY	35,45
WEG680290MA	35,45
WEG680290MF	35,45
WEG680290MWZ	35,45
WEG680290MY	35,45
WEG68030MA	35,45
WEG68030MF	35,45
WEG68030MWZ	35,45

WEG68030MY	35,45
WEG7801	35,45
WEG7802	35,45
WEG78029	45
WEG7803	35,45
WEG7829	35
WEG7901	35,45
WEG7902	35,45
WEG79029	35,45
WEG7903	35,45
WEG8881-P	35,45
WEG8981-P	35,39,45
<b>WEGP</b>	
WEGP1041SW-1	43
<b>WEV</b>	
WEV1081-7H	34,36,43
WEV1081-7SW	24,34,36,37,43
WEV1081H	34,36,42
WEV1081SW	24,34,42
WEV1091SW	24,34,43
WEV1181-7H	34,43
WEV1181-7SW	24,34,36,43
WEV1181H	34,36,43
WEV1181SW	24,34,43
WEV1191H	36
WEV1582-7H	34,36,43
WEV1582-7SW	24,34,36,43
WEV1582H	34,43
WEV1582SW	24,34,43
WEV2364B	28
WEV2364H	34,36,43
WEV2364SW	25,34,37,43
WEV24886H	34,36,43
WEV24886SW	25,34,37,43
WEV2488B	28
WEV2488H	34,36,43
WEV2488SW	25,34,37,43
WEV2501B	28
WEV2501H	34,36,43
WEV2501SW	25,34,37,43
WEV5001-7H	42
WEV5001-7SW	37,42
WEV5001H	42
WEV5001SW	42
WEV5002-7H	42
WEV5002-7SW	42
WEV5002H	42
WEV5002SW	42
WEV5033-7H	42
WEV5033-7SW	42
WEV5111-7SW	33
WEV511SW	33
WEV512-7SW	33
WEV512SW	33

PRODUCT NUMBER INDEX

Item No.	Page
WEV5521-7SW	33
WEV5521SW	33
WEV5522-7SW	33
WEV5522SW	33
WEV5531-7SW	33,37
WEV5531SW	33
WEV5532-7SW	33
WEV5532SW	33
WEV5533-7SW	32
WEV68010MB	35,45
WEV68010MH	35,45
WEV68010MW	35,45
WEV68010SW	35,45
WEV68020MB	35,45
WEV68020MH	35,45
WEV68020MW	35,45
WEV68020SW	35,45
WEV680290MB	35,45
WEV680290MH	35,45
WEV680290MW	35,45
WEV680290SW	35,45
WEV68030MB	35,45
WEV68030MH	35,45
WEV68030MW	35,45
WEV68030SW	35,45
WEV68040MB	35,45
WEV68040MH	35,45
WEV68040MW	35,45
WEV68040SW	35,45
WEV68060MB	35,45
WEV68060MH	35,45
WEV68060MW	35,45
WEV68060SW	35,45
WEV68910MB	35,45
WEV68910MH	35,45
WEV68910MW	35,45
WEV68910SW	35,45
WEV68920SW	35,45
WEV7001MB	35,45
WEV7001MH	35,45
WEV7001MW	35,45
WEV7001SW	35,45
WEV7061MB	35,45
WEV7061MH	35,45
WEV7061MW	35,45
WEV7061SW	35,45
<b>WEVH</b>	
WEVH5003K	24
WEVH5004	24
WEVH5033-7	24
WEVH5151-51	24
WEVH5151-7	24
WEVH5152-51	24

WEVH5152-7	24
WEVH5401-011	25
WEVH5511-7K	24
WEVH5511K	24
WEVH5512	24
WEVH5512-7	24
WEVH5521K	24
WEVH5521-7K	24
WEVH5522	24
WEVH5522-7	24
WEVH5531K	24
WEVH5531-7K	24
WEVH5532	24
WEVH5532-7	24
WEVH5542-7	24
WEVH68010	25
WEVH68020	25
WEVH680290	25
WEVH68030	25
WEVH68040	25
WEVH68060	25
WEVH68910	25
WEVH8061	25
<b>WF</b>	
WF1220BK	53
WF1220WK	53
WF1230BK	53
WF1230WK	53
WF1315BK	53
WF1315WK	53
WF1320BK	53
WF1320WK	53
WF1330BK	53
WF1330WK	53
WF1415BK	53
WF1415WK	53
WF1420BK	53
WF1420WK	53
WF1430BK	53
WF1430WK	53
WF2215BK	51
WF2215WK	51
WF2220BK	51
WF2220WK	51
WF2315BK	51
WF2315WK	51
WF2320BK	51
WF2320WK	51
WF2330B	51
WF2330W	51
WF2331B	51
WF2331W	51
WF2360B	51
WF2360W	51

WF2420BK	51
WF2420WK	51
WF2430B	51
WF2430W	51
WF2460B	51
WF2460W	51
WF2520B	51
WF2520W	51
WF3012WK	53
WF3314	52
WF3315B	52
WF3315W	52
WF3324a	52
WF3334	52
WF3424	52
WF3434	52
WF3524	52
WF3630B	53
WF3630W	53
WF4212	54
WF4215	54
WF4220	54
WF4230	54
WF4315	54
WF4320	54
WF4330	54
WF4415	54
WF4420	54
WF4430	54
WF4630	54
WF5015B	53
WF5015W	53
WF5115B	53
WF5115W	53
WF5215	53,54
WF52153B	53
WF52153W	53
WF5215W	53
WF5220	53,54
WF52201	53
WF5220W	53
WF5315	53,54
WF5315W	53
WF5320	53,54
WF5320W	53
WF5330	53
WF5330W	53
WF5415	53,54
WF5415W	53
WF5420	53,54
WF5420W	53
WF5430	53
WF5430W	53
WF5630	53

Item No.	Page
WF56301B	53
WF56301W	53
WF5630W	53
WF5730B	53
WF5730W	53
WF6215	52
WF62153B	52
WF62153W	52
WF6215W	52
WF6220	52
WF6220W	52
WF6315	52
WF6315W	52
WF6320	52
WF6320W	52
WF6330	52
WF6330W	52
WF6331B	52
WF6331W	52
WF6420	52
WF6420W	52
WF6430	52
WF6430W	52
WF7002	53,54
WF7002W	53
WF7004	54
WF7005K	54
WF7011	53,54
WF7011W	53
WF7013	54
WF7215K	54
WF7220	54
WF7230	54
WF7315	54
WF7320	54
WF7330	54
WF7415	54
WF7420K	54
WF7430	54
WF75159	54
WF7615	54
WF7630	54
WF8215K	52
WF8220K	52
WF8315K	52
WF8320K	52
WF8330	52
WF8331	52
WF8360	52
WF8420K	52
WF8430	52
WF8460	52
WF8520	52

<b>WH</b>	
WH4007	54
<b>WK</b>	
WK1220B	53
WK1220W	53
WK1230	53
WK1315	53
WK1320	53
WK1330	53
WK1415	53
WK1420	53
WK1430	53
WK2215	51
WK2215W	51
WK2220K	51
WK2315K	51
WK2315W	51
WK2320K	51
WK2320W	51
WK2330	51
WK2330W	51
WK2331B	51
WK2331W	51
WK2420K	51
WK2430	51
WK2520B	51
WK2520W	51
WK3630	53
WK36301B	53
WK36301W	53
WK3730B	53
WK3730W	51
WK6315	51
WK6320	51
WK6330	51
WK6331	51
WK6420	51
WK6430	51
WK6520	51
<b>WKG</b>	
WKG1091-250	49
WKG1092-250	49
<b>WMT</b>	
WMT501MYH-VN	20
WMT501MYZ-VN	19
WMT501-VN	18
WMT502MYH-VN	20
WMT502MYZ-VN	19
WMT502-VN	18
WMT503MYH-VN	20
WMT503MYZ-VN	19
WMT503-VN	18
WMT504MYH-VN	20
WMT504MYZ-VN	19

WMT504-VN	18
WMT505MYH-VN	20
WMT505MYZ-VN	19
WMT505-VN	18
WMT506MYH-VN	20
WMT506MYZ-VN	19
WMT506-VN	18
WMT507MYH-VN	20
WMT507MYZ-VN	19
WMT507-VN	18
WMT508MYH-VN	20
WMT508MYZ-VN	19
WMT508-VN	18
WMT540108MYH-VN	20
WMT540108MYZ-VN	19
WMT540108-VN	18
WMT594MYH-VN	20
WMT594MYZ-VN	19
WMT594-VN	18
WMT596MYH-VN	20
WMT596MYZ-VN	19
WMT596-VN	18
WMT6891MYH-VN	21
WMT6891MYZ-VN	21
WMT6891-VN	21
WMT707K-VN	18
WMT707MYHK-VN	20
WMT707MYZK-VN	19
WMT7811MYH-VN	21
WMT7811MYZ-VN	21
WMT7811-VN	21
WMT7812MYH-VN	21
WMT7812MYZ-VN	21
WMT7812-VN	21
WMT7813MYH-VN	21
WMT7813MYZ-VN	21
WMT7813-VN	21
<b>WN</b>	
WN1001-7K-W	49
WN1090-7K-W	49
WN1101-7W	49
WN3020W	49
WN3023W	49
WN5241W-801	48
WN65019-8	50
WN65029-8	50
WN65039-8	50
WN6504K-8	50
WN6506K-8	50
WN7501-8	50
WN7502-8	50
WN7503-8	50
WN7504-8	50
WN7506-8	50

PRODUCT NUMBER INDEX



Item No.	Page
WN7591-8	50
WN7601-8	50
WN7602-8	50
WN7603-8	50
WN7604-8	50
WN7606-8	50
WN7691-8	50
WN7801K-8	50
WN7802K-8	50
WN7803K-8	50
WN7821K-8	50
WN7901-8	50
WN7902-8	50
WN7903-8	50
WN7921-8	50
<b>WNG</b>	
WNG15923-7W	49
WNG5003W-7	48
WNG5004W-7	48
WNG5021W-7	48
WNG5051W-751	48
WNG5052W-751	48
WNG5061W-701	48
WNG5343W-761	48
WNG5401W-7K	48
<b>WNGP</b>	
WNGP575152W	48
WNGP575283W	48
<b>WNH</b>	
WNH5611-801	48
<b>WNTG</b>	
WNTG15649W	49
<b>WNV</b>	
WNV1081-7W	49
WNV1091-7W	49
WNV5001-7W	48
WNV5002-7W	48
<b>WSBC</b>	
WSBC7010MYH-VN	20
WSBC7010MYZ-VN	19
WSBC7010SW-VN	18,37
WSBC9120SW-VN	44
<b>WSG</b>	
WSG3001	48
<b>WTEG</b>	
WTEG6503S-1-G	29
WTEG6506S-1-G	29
WTEG6506S-G	29
<b>WTEGP</b>	
WTEGP51552S-1-G	28
WTEGP52562S-1-G	28
WTEGP53572S-1-G	28
WTEGP54562S-1-G	28

WTEGP55582S-1-G	28
WTEGP56572S-1-G	28
<b>WTFB</b>	
WTFB6503S-1-G	29
<b>WTFBP</b>	
WTFBP52562S-1-G	28
WTFBP53572S-1-G	28
WTFBP51552S-1-G	28
<b>WZV</b>	
WZV1201W	49
WZV7061W	50
WZV7841W	50
WZV7842W	50
WZV7843W	50
WZV7844W	50
WZV7846W	50
<b>EXTENSION CORD</b>	
WCHG243322W-VN	65
WCHG243322W-G	65
WCHG28334	64
WCHG28352	64
WCHG2836	64
<b>FLOOR OUTLET</b>	
<b>DU</b>	
DU5102HTC-1	70
DU51031HTK-1	70
DU5199HTC-1	70
DU5900VT	68
DU59833LT9-1	68
DU59835LT9-1	68
DU5983LT9-1	68
DU5990LT9-1	68
DU5993LT9-1	68
DU61223HTC-1	70
DU612331HTK-1	70
DU61233HTC-1	70
DU612351HTK-1	70
DU61355HTK-1	70
DU61466HTK-1	70
DU6933LT9-1	68
DU6935LT9-1	68
DU6955LT9-1	68
DU7199HTC-1	70
DU8102HTC-1	70
DU81831HTK-1	70
DU81835HTK-1	70
DU81931HTK-1	70
DU8199HTK-1	70

<b>DUF</b>	
DUF1200LTK-1	69
DUF1260LTK-1	69
DUF1270LTK-1	69
DUF2214LTK-1	69
DUF2229LTK-1	69
DUF2259LTK-1	69
DUF3221LTK-1	69
DUF3234LTK-1	69
DUF5200LT-1	69
<b>DUFS</b>	
DUFS1200LTH-1	67
<b>DUMF</b>	
DUMF3200LT-1	67
<b>SENSOR</b>	
<b>WEBFP</b>	
WEBFP57311W-VN	73
<b>WTKF</b>	
WTKF24816-VN	74
<b>WTKG</b>	
WTKG2310	73
WTKG2311	73
WTKG2411	74
WTKG2911	74
<b>SMOKE DETECTOR</b>	
SH28455911	75
<b>AUTOMATIC TIME SWITCH</b>	
TB11N	78
TB17N	78
TB35N	78
TB36N	78
TB38N	78
TB39N	78
TB43N	78
<b>BREAKER</b>	
<b>BBC</b>	
BBC3100YHV	85
BBC31502YHV	85
BBC32001YHV	85
BBC3250YHV	85
BBC3601YHV	85

Item No.	Page
<b>BBD</b>	
BBD1061CNV	80
BBD1061DENV	80
BBD108011C	80
BBD108011D	80
BBD110011C	80
BBD110011D	80
BBD1101CNV	80
BBD1101DENV	80
BBD112511C	80
BBD1161CNV	80
BBD1161DENV	80
BBD1201CNV	80
BBD1201DENV	80
BBD1251CNV	80
BBD1251DENV	80
BBD1321CNV	80
BBD1321DENV	80
BBD1401CNV	80
BBD1401DENV	80
BBD1501CNV	80
BBD1501DENV	80
BBD1631CNV	80
BBD1631DENV	80
BBD2062CNV	80
BBD2062DENV	80
BBD208021C	80
BBD208021D	80
BBD210021C	80
BBD210021D	80
BBD2102CNV	80
BBD2102DENV	80
BBD212521C	80
BBD2162CNV	80
BBD2162DENV	80
BBD2202CNV	80
BBD2202DENV	80
BBD2252CNV	80
BBD2252DENV	80
BBD2322CNV	80
BBD2322DENV	80
BBD2402CNV	80
BBD2402DENV	80
BBD2502CNV	80
BBD2502DENV	80
BBD2632CNV	80
BBD2632DENV	80
BBD3063CNV	80
BBD3063DENV	80
BBD308031C	80
BBD308031D	80
BBD310031C	80
BBD310031D	80

BBD3103CNV	80
BBD3103DENV	80
BBD312531C	80
BBD3163CNV	80
BBD3163DENV	80
BBD3203CNV	80
BBD3203DENV	80
BBD3253CNV	80
BBD3253DENV	80
BBD3323CNV	80
BBD3323DENV	80
BBD3403CNV	80
BBD3403DENV	80
BBD3503CNV	80
BBD3503DENV	80
BBD3633CNV	80
BBD3633DENV	80
BBD4064CNV	80
BBD4064DENV	80
BBD408041C	80
BBD408041D	80
BBD410041C	80
BBD410041D	80
BBD4104CNV	80
BBD4104DENV	80
BBD412541C	80
BBD4164CNV	80
BBD4164DENV	80
BBD4204CNV	80
BBD4204DENV	80
BBD4254CNV	80
BBD4254DENV	80
BBD4324CNV	80
BBD4324DENV	80
BBD4404CNV	80
BBD4404DENV	80
BBD4504CNV	80
BBD4504DENV	80
BBD4634CNV	80
BBD4634DENV	80
<b>BBDE</b>	
BBDE20631CNV	81
BBDE20631DENV	81
BBDE20641CNV	81
BBDE20641DENV	81
BBDE20651CNV	81
BBDE20651DENV	81
BBDE21031CNV	81
BBDE21031DENV	81
BBDE21041CNV	81
BBDE21041DENV	81
BBDE21051CNV	81
BBDE21051DENV	81
BBDE21631CNV	81

BBDE21631DENV	81
BBDE21641CNV	81
BBDE21641DENV	81
BBDE21651CNV	81
BBDE21651DENV	81
BBDE22031CNV	81
BBDE22031DENV	81
BBDE22041CNV	81
BBDE22041DENV	81
BBDE22051CNV	81
BBDE22051DENV	81
BBDE22531CNV	81
BBDE22531DENV	81
BBDE22541CNV	81
BBDE22541DENV	81
BBDE22551CNV	81
BBDE22551DENV	81
BBDE23231CNV	81
BBDE23231DENV	81
BBDE23241CNV	81
BBDE23241DENV	81
BBDE23251CNV	81
BBDE23251DENV	81
BBDE24031CNV	81
BBDE24031DENV	81
BBDE24041CNV	81
BBDE24041DENV	81
BBDE24051CNV	81
BBDE24051DENV	81
BBDE25031CNV	81
BBDE25031DENV	81
BBDE25041CNV	81
BBDE25041DENV	81
BBDE25051CNV	81
BBDE25051DENV	81
BBDE26331CNV	81
BBDE26331DENV	81
BBDE26341CNV	81
BBDE26341DENV	81
BBDE26351CNV	81
BBDE26351DENV	81
BBDE40634CNV	81
BBDE40644CNV	81
BBDE40654CNV	81
BBDE41034CNV	81
BBDE41044CNV	81
BBDE41054CNV	81
BBDE41634CNV	81
BBDE41644CNV	81
BBDE41654CNV	81
BBDE42034CNV	81
BBDE42044CNV	81
BBDE42054CNV	81
BBDE42534CNV	81

Item No.	Page
BBDE42544CNV	81
BBDE42554CNV	81
BBDE43234CNV	81
BBDE43244CNV	81
BBDE43254CNV	81
BBDE44034CNV	81
BBDE44044CNV	81
BBDE44054CNV	81
BBDE45034CNV	81
BBDE45044CNV	81
BBDE45054CNV	81
BBDE46334CNV	81
BBDE46344CNV	81
BBDE46354CNV	81
<b>BBW</b>	
BBW2100KY	89
BBW2101SKY	88
BBW2102Y	89
BBW210CKY	88
BBW210Y	88
BBW2151SKY	88
BBW2152Y	89
BBW215CKY	88
BBW215Y	88
BBW2201SKY	88
BBW2201Y	88
BBW2202Y	89
BBW2203KY	89
BBW220CKY	88
BBW220Y	88
BBW22501KY	89
BBW23001KY	89
BBW2301SKY	88
BBW2301Y	88
BBW2302Y	89
BBW2303KY	89
BBW230CKY	88
BBW230Y	88
BBW232Y	89
BBW2350KY	89
BBW23CKY	88
BBW23Y	88
BBW2400KY	89
BBW2401Y	89
BBW2402KY	89
BBW240SKY	88
BBW240Y	88
BBW2501Y	89
BBW2502KY	89
BBW250SKY	88
BBW250Y	88
BBW251SKY	88
BBW252Y	89

BBW25CKY	88
BBW25Y	88
BBW2601KY	89
BBW260SKY	89
BBW260Y	89
BBW275KY	89
BBW3100KY	89
BBW3101SKY	88
BBW3102Y	89
BBW310CKY	88
BBW310Y	88
BBW3151SKY	88
BBW3152Y	89
BBW315CKY	88
BBW315Y	88
BBW3201SKY	88
BBW3201Y	88
BBW3202Y	89
BBW3203KY	89
BBW320CKY	88
BBW320Y	88
BBW32501KY	89
BBW33001KY	89
BBW3301SKY	88
BBW3301Y	88
BBW3302Y	89
BBW3303KY	89
BBW330CKY	88
BBW330Y	88
BBW332Y	89
BBW3350KY	89
BBW33CKY	88
BBW33Y	88
BBW3400KY	89
BBW3401Y	89
BBW3402KY	89
BBW340SKY	88
BBW340Y	88
BBW3501Y	89
BBW3502KY	89
BBW350SKY	88
BBW350Y	88
BBW351SKY	88
BBW352Y	89
BBW35CKY	88
BBW35Y	88
BBW3601KY	89
BBW360SKY	89
BBW360Y	89
BBW375KY	89
<b>BJJ</b>	
BJJ215228	84
BJJ215328	84
BJJ220228	84

BJJ220328	84
BJJ230228	84
BJJ230308	84
BJJ230328	84
<b>BJS</b>	
BJS1512S	83
BJS1522S	83
BJS1532S	83
BJS2012S	83
BJS2022S	83
BJS2032S	83
BJS3012S	83
BJS3020NA2	83
BJS3022S	83
BJS3030NA2	83
BJS3032S	83
<b>BKW</b>	
BKW210□CKY	90
BKW210□Y	90
BKW2100□KY	91
BKW215□1CKY	90
BKW215□1SKY	91
BKW215□CKY	90
BKW215□Y	90,91
BKW220□1CKY	90
BKW220□1SKY	91
BKW220□1Y	90
BKW220□CKY	90
BKW220□Y	90,91
BKW23□Y	90
BKW230□1CKY	90
BKW230□1SKY	91
BKW230□1Y	90
BKW230□CKY	90
BKW230□Y	90,91
BKW240□CKY	90
BKW240□SKY	91
BKW240□Y	90,91
BKW25□CKY	90
BKW25□Y	90
BKW250□CKY	90
BKW250□SKY	91
BKW250□Y	90,91
BKW260□1KY	91
BKW260□SKY	91
BKW260□Y	91
BKW275□KY	91
BKW310□CKY	90
BKW310□Y	90
BKW3100□KY	91
BKW315□1CKY	90
BKW315□1SKY	91
BKW315□CKY	90
BKW315□Y	90,91

Item No.	Page
BKW320□1CKY	90
BKW320□1SKY	91
BKW320□1Y	90
BKW320□CKY	90
BKW320□Y	90,91
BKW3250□1KY	91
BKW33□Y	90
BKW330□1CKY	90
BKW330□1SKY	91
BKW330□1Y	90
BKW330□CKY	90
BKW330□Y	90,91
BKW3300□1KY	91
BKW3350□KY	91
BKW340□CKY	90
BKW340□SKY	91
BKW340□Y	90,91
BKW3400□KY	91
BKW35□CKY	90
BKW35□Y	90
BKW350□CKY	90
BKW350□SKY	91
BKW350□Y	90,91
BKW360□1KY	91
BKW360□SKY	91
BKW360□Y	91
BKW375□KY	91
<b>BS</b>	
BS11106TV	84
BS1110TV	84
BS1111TV	84
BS1112TV	84
BS1113TV	84
BS1114TV	84

**CONDUIT PIPE**

<b>DW</b>	
DW119T	100
DW125T	100
DW131T	100
DW139T	100
DW151T	100
DW163T	100
DW175T	100
DW216T	101
DW222T	101
DW228T	101
DW236T	101
DW242T	101
DW254T	101
DW270T	101

DW282T	101
DW392T	101
DW394T	101
DW819T	100
DW825T	100
DW831T	100
DW839T	100
DW851T	100
DW863T	100
DW875T	100
<b>DWB</b>	
DWB0203	99
DWB0204	99
DWB0253	99
DWB0254	99
DWB0323	99
DWB0324	99
DWB0343L	99
DWB0343S	99
DWB1003L	99
DWB1003S	99
DWB1123L	99
DWB1123S	99
DWB1143L	99
DWB1143S	99
DWB2003L	99
DWB2003S	99
<b>DWE</b>	
DWE012	99
DWE012Y	97
DWE034	99
DWE034Y	97
DWE100	99
DWE100Y	97
DWE112Y	97
DWE114Y	97
DWE200Y	97
DWE212Y	97
DWE300Y	97
DWE312Y	97
DWE400Y	97
<b>DWM</b>	
DWM012Y	97
DWM034Y	97
DWM100Y	97
DWM112Y	97
DWM114Y	97
DWM200Y	97
DWM212Y	97
DWM300Y	97
DWM312Y	97
DWM400Y	97
<b>DWR</b>	
DWR012Y	98

DWR012ZY	98
DWR034Y	98
DWR034ZY	98
DWR100Y	98
DWR100ZY	98
DWR112Y	98
DWR112ZY	98
DWR114Y	98
DWR114ZY	98
DWR200Y	98
DWR200ZY	98
DWR212ZY	98
DWR300ZY	98
DWR312ZY	98
DWR400ZY	98
DWR500ZY	98
DWR600ZY	98
<b>DWZ</b>	
DWZ216T	101
DWZ222T	101
DWZ228T	101
DWZ236T	101
DWZ242T	101
DWZ254T	101
DWZ270T	101
DWZ282T	101
DWZ392T	101
DWZ394T	101

**FACTORY LINE SYSTEMS**

<b>DGHU</b>	
DGHU2311	106
DGHU2312	106
DGHU2313	106
DGHU2411	106
DGHU2412	106
DGHU2413	106
DGHU2421	106
DGHU2422	106
DGHU2481	106
DGHU2611	106
DGHU2612	106
DGHU2613	106
DGHU2621K1	106
DGHU2622K1	106
DGHU2631K1	106
DGHU2683	106
DGHU2711	106
DGHU2712	106
DGHU2713	106
DGHU2721	106
DGHU2722	106

Item No.	Page
DGHU2731	106
DGHU2781	106
DGHU2782	106
DGHU2783	106
DGHU2784	106
<b>DH</b>	
DH2423K	106
DH2431	106
DH2451	106
DH2452K1	106
DH2461	106
DH24621W	106
DH2463	106
DH24641W	106
DH2477	106
DH2623	106
DH2651	106
DH2652	106
DH2670	106
DH2671	106
DH26751W	106
DH26771W	106
DH2684	106
DH2723	106
DH2751	106
DH2752K1	106
DH2773	106
DH2774	106
DH27751W	106
DH27761W	106
DH27781W	106
DH27791W	106
DH2791	106
DH2792	106

**PHOTOVOLTAIC  
MODULE HIT**

<b>N</b>	
N325 (VBHN325SJ47)	108
<b>VBMS</b>	
VBMS290AJ07	108
VBMS380AJ09	108

**VENTILATING FAN  
& AIR MOVING  
EQUIPMENT**

**VENTILATING FAN**

Item No.	Page
FV-24CUR1	115
FV-24CHR1	115
FV-24CURV1	115
FV-24CHRV1	115
FV-17CU9	116
FV-24CU9	116
FV-24CD9	116
FV-24CH9	116
FV-27CH9	117
FV-32CD9	117
FV-32CH9	117
FV-38CD8	118
FV-38CH8	118
FV-20CUT1	118
FV-15TGU1	118
FV-25TGU5	118
FV-12NS3	120
FV-15NS3	120
FV-18NS3	120
FV-18NF3	120
FV-20NS3	121
FV-20NL3	121
FV-25NS3	121
FV-25NF3	121
FV-25SW3	122
FV-25SM3	122
FV-28NX3	123
FV-25GS4	125
FV-30GS4	125
FV-35GS4	125
FV-40GS4	126
FV-45GS4	126
FV-50GS4	126
FV-60GS4	126
FV-45GT4	127
FV-50GT4	127

FV-60GT4	127
FV-10EGS1	129
FV-15EGS1	129
FV-10EGF1	129
FV-15EGF1	129
FV-25AUF1	130
FV-20AU1	130
FV-25AU1	130
FV-30AU1	130
FV-15AUL1	131
FV-20AL1	131
FV-25AL1	131
FV-30AL1	131
FV-20RL1	132
FV-25RL1	132
FV-30RL1	132

**BATHROOM DRYER**

FV-30BG3	134
----------	-----

**AIR CURTAIN**

FV-3509U1	136
FV-3512U1	136
FV-4009U1	136
FV-4012U1	136

**HAND DRYER**

FJ-T09A3	138
FJ-T09B3	138

**CEILING FAN &  
ELECTRIC FAN**

F-60DGN	143
F-60DHN	143
F-48DGL	144
F-60UFN	145
F-60TDN	146
F-60WWK	146
F-56XPG	147
F-56MPG	147
F-56MZG	148
F-60MZ2	148
F-56NCL	149
F-48CZL	149
F-70ZBP	150

F-80ZBR	150
F-409Q	151
F-50YUZ	151
F-409U	152
F-409M	152
F-409K	153
F-407W	153
F-308NH	154
F-307KH	154
F-400C	154

**AIR PURIFIER**

F-PXM55A	163
F-PXM35A	163
F-PXJ30A	163
F-P15EHA	163

**AIR-E**

FV-15CSD1	164
F-PXU70A	165
F-PXV50A	165
F-VXV70A	166
F-GPT01A	166

**DEHUMIDIFIER**

F-YCT10V	167
F-YCT14V	167
F-YCT17V	167

**ZIAINO™**

F-JPU70A	168
----------	-----

**PUMP**

<b>A</b>	
A-130JACK	170
A-130JAK	170
A-130JTX	170
A-200JAK	170
<b>GA</b>	
GA-125FAK	170
<b>GP</b>	
GP-10HCN1SVN	171
GP-129JXK	171
GP-15HCN1SVN	171
GP-200JXK	171
GP-20HCN1SVN	171
GP-250JXK	171
GP-350JA	171



Lined writing area for page 182.



Lined writing area for page 183.